

Transmittal Number PT 13-049	Date July 2013
Publication Distribution To: Design Manual Holders	
Publication Title Design Manual – July 2013	Publication Number M 22-01.10
Originating Organization WSDOT Development Division, Design Office – Design Policy, Standards, and Safety Research Section	

## Remarks and Instructions

### *What's changed in the Design Manual for July 2013?*

For a summary of the 2013 Substantial Revisions, Minor Revisions, and Technical Errata and Spot Corrections, see page 3.

### *How do you stay connected to current design policy?*

It's the designer's responsibility to apply current design policy when developing transportation projects at WSDOT. The best way to know what's current is to reference the manual online.

Download the current electronic WSDOT *Design Manual*, the latest revision package, and individual chapters at: [www.wsdot.wa.gov/publications/manuals/m22-01.htm](http://www.wsdot.wa.gov/publications/manuals/m22-01.htm)

*We're ready to help. If you have comments or questions about the Design Manual, please don't hesitate to contact us.*

Area of Practice	Your Contacts		
<b>Geometric Design</b>	<b>Position Vacant as of August 2013. Qualified licensed engineers are encouraged to apply.</b>		
<b>Roadside Safety and Traffic Barriers</b>	Jeff Petterson	360-705-7246	<a href="mailto:PETTERJ@wsdot.wa.gov">PETTERJ@wsdot.wa.gov</a>
<b>General Guidance and Support</b>	Chris Schroedel	360-705-7299	<a href="mailto:SCHROEC@wsdot.wa.gov">SCHROEC@wsdot.wa.gov</a>
	John Donahue	360-705-7952	<a href="mailto:DONAHJO@wsdot.wa.gov">DONAHJO@wsdot.wa.gov</a>

### *To get the latest information on individual WSDOT publications:*

Sign up for email updates at: [www.wsdot.wa.gov/publications/manuals/](http://www.wsdot.wa.gov/publications/manuals/)

HQ Design Office Signature <b>/s/ Pasco Bakotich III</b>	Phone Number 360-705-7952
---	------------------------------

**Remove/Insert instructions for those who maintain a printed manual**

NOTE: Replace the **Title Page**, **Foreword**, and **Comment Form** in both volumes, and add the new **Glossary** where it's most convenient for you.

VOLUME 1		
CHAPTER/SECTION	REMOVE PAGES	INSERT PAGES
Contents/Exhibits	Volume 1-1 – 1-12	Volume 1-1 – 1-12
100 Manual Description	100-1 – 8	100-1 – 8
120 Planning	120-17&18	120-17&18
130 Project Development Sequence	130-9 – 10	130-9 – 10
210 Public Involvement and Hearings	210-1&2, 5&6, 21–24	210-1&2, 5&6, 21–24
220 Project Environmental Documentation	Entire Chapter	<b>Retired</b>
225 Environmental Coordination	<b>NEW</b>	225-1 – 4
230 Environmental Permits and Approvals	Entire Chapter	<b>Retired</b>
300 Design Documentation, Approval, and Process Review	300-1 – 22	300-1 – 18
305 Managing Projects	305-1&2	305-1&2
310 Value Engineering	Entire Chapter	310-1–10
410 Monumentation	410-1 – 6	410-1 – 6
550 Interchange Justification Report	550-21&22	550-21&22
560 Fencing	560-3&4	560-3&4
610 Investigation of Soils, Rock, and Surfacing Materials	Entire Chapter	610-1 – 18
620 Design of Pavement Structure	620-1&2	620-1&2
630 Geosynthetics	630-1&2, 13&14	630-1&2, 13&14
710 Site Data for Structures	710-1 – 4	710-1 – 4
720 Bridges	720-7 – 10	720-7 – 10
730 Retaining Walls and Steep Reinforced Slopes	730-3–6, 11–18, 29–32	730-3–6, 11–18, 29–32
740 Noise Barriers	740-5&6	740-5&6
800 Hydraulic Design	800-1&2	800-1&2
1010 Work Zone Safety and Mobility	1010-3&4	1010-3&4
VOLUME 2		
CHAPTER/SECTION	REMOVE PAGES	INSERT PAGES
Contents/Exhibits	Volume 2-1 – 2-20	Volume 2-1 – 2-18
1130 Modified Design Level	1130-7 – 10	1130-7 – 10
1220 Geometric Profile Elements	1220-5&6	1220-5&6
1260 Sight Distance	1260-1 – 16	1260-1 – 14
1300 Intersection Control Type	<b>NEW</b>	1300-1 – 16
1310 Intersections	Entire Chapter	1310-1 – 44
1320 Roundabouts	1320-1 – 50	1320-1 – 24
1330 Traffic Control Signals	1330-1&2, 7&8	1330-1&2, 7&8
1340 Driveways	Entire Chapter	1340-1 – 6
1350 Railroad Grade Crossings	1350-1 – 4	1350-1 – 4
1360 Interchanges	1360-21 – 24	1360-21 – 24
1420 HOV Direct Access	1420-1 – 34	1420-1 – 28
1430 Transit Facilities	1430-5&6	1430-5&6
1510 Pedestrian Facilities	Entire Chapter	1510-1 – 44
1600 Roadside Safety	Entire Chapter	1600-1 – 22
1610 Traffic Barriers	Entire Chapter	1610-1 – 40

## **Summary of *Design Manual* Changes – July 2013** (Revisions merit careful study beyond this summary)

### **Highlights of the More Substantial Revisions**

#### **Chapter 1260 – Sight Distance**

- Revised the evaluation of 6-in object height to 2.0 ft
- Added object/eye height criteria in each section title
- Moved Definitions section to the new Glossary
- Revised values of passing sight distance to align with 2011 Green Book & MUTCD

#### **Chapter 1300 – Intersection Control Type (New)**

- This chapter provides guidance on preliminary intersection analysis and selection of control type

#### **Chapter 1310 – Intersections**

- Revised intersection angle criteria
- Added new policy on lane alignment
- Moved some content to Chapters 1300 and 1420
- Revised right-turn corner criteria to initial ranges for flexibility
- Revised deceleration lengths to meet AASHTO auxiliary lane deceleration lengths
- Revised chapter name

#### **Chapter 1320 – Roundabouts**

- Revised design criteria
- Added new photos and updated exhibits
- Added information on noncircular roundabouts
- Added discussion on chicanes
- Changed fastest paths philosophy to travel paths
- Changed the conceptual design meeting to preliminary geometry design meeting (conceptual meeting is now covered in the new Chapter 1300)

#### **Chapter 1340 – Driveways**

- Rewrote chapter
- Revised the approach templates
- Applied new title
- Clarified text and tables
- Updated Driveway Sight Distance table
- Updated “SU” to “SU-30”

#### **Chapter 1420 – HOV Direct Access**

- Moved related policy from Chapter 1310 to this chapter
- Added new section: Wrong Way Driving Countermeasures
- Moved exhibits near their text
- Moved Definitions section to new Glossary
- Made minor text revisions

## **Chapter 1510 – Pedestrian Facilities**

- Edited Jurisdiction text
- Added new section: Transition Planning
- Moved Definitions section to new Glossary
- Added text under Alteration Projects
- Inserted four new exhibits
- Edited Sidewalks and Buffer Widths section
- Made extensive changes to Pedestrian Pushbuttons at Signals section
- Added guidance and criteria related to handrails
- Revised Documentation section to direct reader to Chapter 300
- Revised some notes on Exhibit 1510-32

## **Chapter 1600 – Roadside Safety**

- Added additional guidance on centerline rumble strips
- Added guidance from *Roadside Manual*
- Revised section covering responsibilities inside cities; added new cross-section exhibit per recently signed maintenance agreement between the state and the Association of Washington Cities

## **Chapter 1610 – Traffic Barriers**

- Made revisions to reflect changes to WSDOT’s “Preservation Programming” criteria
- Updated policy and rearranged text to clarify current policy
- Moved text related to Scenic Byways
- Revised LR values to reflect current AASHTO guidance
- Removed outdated text related to guardrail post usage
- Updated criteria for the use of long post guardrail systems

## **Minor Revisions**

### **Chapter 100 – Manual Description**

- To align with office name change, changed “Engineering Publications” to “Publications Services”
- Added description of new Chapters 225, Environmental Coordination, and 1300, Intersection Control Type
- Deleted Chapters 220 and 230
- Added link to Active *Design Manual* Revisions website

### **Chapter 225 – Environmental Coordination (New)**

- Composed this chapter from material taken from Chapters 220 and 230, both of which are now retired; no new policy has been created by this chapter
- Retention of environmental documents is covered to some extent, and by extension, is the official source for that direction
- Covers the commitment file and permits, giving designers a brief overview and direction to the resources: environmental office staff in their region, the EPM, and online EPM-related material
- The EPM will be updated by HQ Environmental Services Office to add additional guidance on retention

### **Chapter 300 – Design Documentation, Approval, and Process Review**

- Updated links to DDP and Project File checklists
- Moved Definitions section to the new Glossary
- Added Intersection Control Type to Exhibit 300-3, Approvals (per new Chapter 1300)
- Revised Exhibit 300-4 related to stockpiled/salvaged materials, per PPM policy changes

## **Chapter 310 – Value Engineering**

- Clarified references under section 310.02 and added OMB Circular A-131 as a reference
- Removed prescriptive language under VE Analysis timing in section 310.03(3)(b)
- Moved Definitions section to new Glossary
- Applied full numbering to subsections

## **Chapter 410 – Monumentation**

- Revised to provide property corner monumentation procedure
- Moved Definitions section to the new Glossary

## **Chapter 550 – Interchange Justification Report**

- Added “Development Services and Access Manager” to the IJR Stamped Cover Sheet Example

## **Chapter 560 – Fencing**

- Removed Type C approach reference
- Changed reference from Chapter 1340 to Chapter 530

## **Chapter 1130 – Modified Design Level**

- Updated design vehicles in Exhibit 1130-7
- Changed the text for intersection angle criteria to meet the revised criteria in Chapter 1310
- Changed Documentation section to refer to Chapter 300
- Added reference to the Glossary
- Added references to Chapters 1515 and 1300

## **Chapter 1350 – Railroad Grade Crossings**

- Updated links in References section
- Deleted text regarding sight distance at railroad crossings

## **Technical Errata and Spot Corrections**

### **Chapter 120 – Planning**

- Changed reference from Chapter 220 to Chapter 225

### **Chapter 130 – Project Development Sequence**

- Changed reference from Chapter 220 to Chapter 225

### **Chapter 210 – Public Involvement and Hearings**

- Under “Design Guidance” in 210.02, changed reference from Chapter 220 to Chapter 225 and updated a division reference
- On page 6, replaced text that was inadvertently omitted when pagination changed in 2012

### **Chapter 305 – Managing Projects**

- Updated link to the glossary of project management terms

### **Chapter 610 – Investigation of Soils, Rock, and Surfacing Materials**

- Updated link to WSDOT Pavements website
- Changed “HQ Geotechnical Services Division” to “HQ Geotechnical Office”

## **Chapter 620 – Design of Pavement Structure**

- Updated link to WSDOT *Pavement Policy*

## **Chapter 630 – Geosynthetics**

- Updated link to WSDOT *Pavement Policy*
- Changed “HQ Geotechnical Services Division” to “HQ Geotechnical Office”

## **Chapter 710 – Site Data for Structures**

- Changed reference from Chapter 230 to Chapter 225
- Added reference to the *Environmental Procedures Manual*
- Changed “HQ Geotechnical Services Division” to “HQ Geotechnical Office”

## **Chapter 720 – Bridges**

- Changed “HQ Geotechnical Services Division” to “HQ Geotechnical Office”

## **Chapter 730 – Retaining Walls and Steep Reinforced Slopes**

- Changed “HQ Geotechnical Services Division” to “HQ Geotechnical Office”

## **Chapter 740 – Noise Barriers**

- Changed “HQ Geotechnical Services Division” to “HQ Geotechnical Office”

## **Chapter 800 – Hydraulic Design**

- Changed reference from Chapters 220 and 230 to Chapter 225

## **Chapter 1010 – Work Zone Safety and Mobility**

- Updated link to EO E 1001, Work Zone Safety and Mobility

## **Chapter 1220 – Geometric Profile Elements**

- Changed reference from Chapter 230 to the *Environmental Procedures Manual*
- Removed two references to Chapter 1310

## **Chapter 1330 – Traffic Control Signals**

- Added reference to Intersection Control Analysis

## **Chapter 1360 – Interchanges**

- Changed reference from Chapters 1310 and 1320 to Chapter 1300
- Removed two references to Chapter 1310

## **Chapter 1430 – Transit Facilities**

- Removed a reference to Chapter 220

### ***About revision marks:***

- A new date appears on the footer of each page that has changes or new/different pagination.
- When a chapter is new or substantially rewritten (like 1300 or 1310), no revision marks are applied.



Washington State  
Department of Transportation

---

# Design Manual

## Volume 1 – Procedures

M 22-01.10

July 2013

Division 1 – General Information  
Division 2 – Hearings, Environmental, and Permits  
Division 3 – Project Documentation  
Division 4 – Surveying  
Division 5 – Right of Way and Access Control  
Division 6 – Soils and Paving  
Division 7 – Structures  
Division 8 – Hydraulics  
Division 9 – Roadside Development  
Division 10 – Traffic Safety Elements

**Engineering and Regional Operations**

Development Division, Design Office

## **Americans with Disabilities Act (ADA) Information**

Materials can be provided in alternative formats by calling the ADA Compliance Manager at 360-705-7097. Persons who are deaf or hard of hearing may contact that number via the Washington Relay Service at 7-1-1.

## **Title VI Notice to Public**

It is Washington State Department of Transportation (WSDOT) policy to ensure no person shall, on the grounds of race, color, national origin, or sex, as provided by Title VI of the Civil Rights Act of 1964, be excluded from participation in, be denied the benefits of, or be otherwise discriminated against under any of its federally funded programs and activities. Any person who believes his/her Title VI protection has been violated may file a complaint with WSDOT's Office of Equal Opportunity (OEO). For Title VI complaint forms and advice, please contact OEO's Title VI Coordinator at 360-705-7082 or 509-324-6018.

To get the latest information on individual WSDOT publications, sign up for email updates at:  
 [www.wsdot.wa.gov/publications/manuals](http://www.wsdot.wa.gov/publications/manuals)



## Foreword

---

The *Design Manual* is for use by Washington State Department of Transportation engineering personnel. It provides policies, procedures, and methods for developing and documenting the design of improvements to the transportation network in Washington. It has been developed for state facilities and may not be appropriate for all county roads or city streets that are not state highways.

The *Design Manual* supplements the engineering analyses and judgment that must be applied to Improvement and Preservation projects. It provides uniform procedures for documenting and implementing design decisions.

The Federal Highway Administration has agreed to approve designs that follow the guidance in the *Design Manual*; therefore, following the guidance is mandatory for state highway projects. When proposed designs meet the requirements contained in the *Design Manual*, little additional documentation is required.

The design environment changes rapidly, often without warning to the practitioner. To track every change, and to make improvements based upon each change, is not feasible. The intent of this manual is to provide recommended values for critical dimensions. Flexibility is permitted to encourage independent design tailored to individual situations. However, when flexibility is applied to a proposed design and the critical dimensions do not meet *Design Manual* criteria, additional documentation is required to record the decision-making process.

The addition of new or modified design criteria to the *Design Manual* through the revision process does not imply that existing features are deficient or inherently dangerous. Nor does it suggest or mandate immediate engineering review or initiation of new projects.

The *Design Manual* emphasizes cost-effective, environmentally conscious, and context sensitive design. Designers are encouraged to view the highway corridor beyond the vehicular movement context, so guidance regarding the use of the highway corridor by transit, pedestrians, and bicyclists is included. To accommodate multimodal use, the criteria provided for one mode is to be appropriately adapted to individual locations.

The complexity of transportation design requires the designer to make fundamental trade-off decisions that balance competing considerations. Although this adds to the complexity of design, it acknowledges the unique needs of specific projects and the relative priorities of various projects and programs. Improvements must necessarily be designed and prioritized in light of finite transportation funding.

Updating the *Design Manual* is an ongoing process and revisions are issued regularly. Comments, questions, and improvement ideas are welcomed. Use the comment form on the next page or the contact information on the Design Policy Internet Page: [www.wsdot.wa.gov/design/policy](http://www.wsdot.wa.gov/design/policy)

---

/s/ Pasco Bakotich III

**Pasco Bakotich III, P.E.**  
Director & State Design Engineer,  
Development Division



## Comment Form

---

From: \_\_\_\_\_ Date: \_\_\_\_\_  
\_\_\_\_\_  
\_\_\_\_\_ Phone: \_\_\_\_\_  
\_\_\_\_\_

To: WSDOT Headquarters  
Development Division, Design Office  
Attn: Policy, Standards, and Research Section  
PO Box 47329  
Olympia, WA 98504-7329

Subject: *Design Manual* Comment

Comment (marked copies attached):



## Division 1 – General Information

- Chapter 100 Manual Description**
  - 100.01 Purpose
  - 100.02 Presentation and Revisions
  - 100.03 Manual Applications
  - 100.04 Manual Use
  - 100.05 Manual Organization
  
- Chapter 110 Design-Build Projects**
  - 110.01 General
  - 110.02 References
  - 110.03 Terminology and Language Used
  - 110.04 Design and Documentation Responsibility
  
- Chapter 120 Planning**
  - 120.01 General
  - 120.02 References
  - 120.03 Acronyms and Definitions
  - 120.04 Legislation and Policy Development
  - 120.05 Planning at WSDOT
  - 120.06 Linking Transportation Plans
  - 120.07 Linking WSDOT Planning to Programming
  
- Chapter 130 Project Development Sequence**
  - 130.01 General
  - 130.02 References
  - 130.03 Definitions
  - 130.04 Project Development Sequence

## Division 2 – Hearings, Environmental, and Permits

- Chapter 210 Public Involvement and Hearings**
  - 210.01 General
  - 210.02 References
  - 210.03 Definitions
  - 210.04 Public Involvement
  - 210.05 Public Hearings
  - 210.06 Environmental Hearing
  - 210.07 Corridor Hearing
  - 210.08 Design Hearing
  - 210.09 Limited Access Hearing
  - 210.10 Combined Hearings
  - 210.11 Administrative Appeal Hearing
  - 210.12 Follow-Up Hearing
  - 210.13 Documentation

- Chapter 225 Environmental Coordination**
- 225.01 General
  - 225.02 References
  - 225.03 Determining the Environmental Documentation
  - 225.04 Identifying the Project Classification
  - 225.05 Environmental Commitment File
  - 225.06 Environmental Permits and Approvals
  - 225.07 Documentation

### **Division 3 – Project Documentation**

- Chapter 300 Design Documentation, Approval, and Process Review**
- 300.01 General
  - 300.02 References
  - 300.03 Definitions
  - 300.04 Design Documentation
  - 300.05 Project Development
  - 300.06 FHWA Approval
  - 300.07 Design Approval
  - 300.08 Project Development Approval
  - 300.09 Process Review
- Chapter 305 Managing Projects**
- 305.01 Introduction
  - 305.02 References
  - 305.03 Definitions
  - 305.04 Design Project Management Overview
  - 305.05 Cost Estimating for Design Project Development
  - 305.06 Value Engineering
  - 305.07 Context Sensitive Design (CSS)
  - 305.08 Additional Design Resources
- Chapter 310 Value Engineering**
- 310.01 General
  - 310.02 References
  - 310.03 Statewide VE Program
  - 310.04 VE Procedure
  - 310.05 Documentation
- Chapter 320 Traffic Analysis**
- 320.01 General
  - 320.02 References
  - 320.03 Design Year
  - 320.04 Definitions
  - 320.05 Travel Forecasting (Transportation Modeling)
  - 320.06 Traffic Analysis
  - 320.07 Scope of Traffic Impact Analysis
  - 320.08 Traffic Data
  - 320.09 Traffic Impact Analysis Methodologies
  - 320.10 Traffic Analysis Software
  - 320.11 Mitigation Measures
  - 320.12 Traffic Impact Analysis Report

## Division 4 – Surveying

### Chapter 400 Surveying and Mapping

- 400.01 General
- 400.02 References
- 400.03 Procedures
- 400.04 Datums
- 400.05 Global Positioning System
- 400.06 WSDOT Survey Monument Database
- 400.07 Geographic Information System
- 400.08 Photogrammetric Surveys
- 400.09 Documentation

### Chapter 410 Monumentation

- 410.01 General
- 410.02 References
- 410.03 Control Monuments
- 410.04 Alignment Monuments
- 410.05 Property Corners
- 410.06 Other Monuments
- 410.07 Filing Requirements
- 410.08 Documentation

## Division 5 – Right of Way and Access Control

### Chapter 510 Right of Way Considerations

- 510.01 General
- 510.02 References
- 510.03 Special Features
- 510.04 Easements and Permits
- 510.05 Programming for Funds
- 510.06 Appraisal and Acquisition
- 510.07 Transactions
- 510.08 Documentation

### Chapter 520 Access Control

- 520.01 General
- 520.02 References
- 520.03 Definitions
- 520.04 Vocabulary

### Chapter 530 Limited Access Control

- 530.01 General
- 530.02 Achieving Limited Access
- 530.03 Full Control (Most Restrictive)
- 530.04 Partial Control
- 530.05 Modified Control (Least Restrictive)
- 530.06 Access Approaches
- 530.07 Frontage Roads
- 530.08 Turnbacks
- 530.09 Adjacent Railroads
- 530.10 Modifications to Limited Access Highways
- 530.11 Documentation

- 
- Chapter 540 Managed Access Control**
- 540.01 General
  - 540.02 References
  - 540.03 Definitions
  - 540.04 Design Considerations
  - 540.05 Managed Access Highway Classes
  - 540.06 Corner Clearance Criteria
  - 540.07 Access Connection Categories
  - 540.08 Access Connection Permit
  - 540.09 Permitting and Design Documentation
  - 540.10 Other Considerations
  - 540.11 Preconstruction Conference
  - 540.12 Adjudicative Proceedings
  - 540.13 Documentation
- Chapter 550 Interchange Justification Report**
- 550.01 General
  - 550.02 References
  - 550.03 Definitions
  - 550.04 Procedures
  - 550.05 Interchange Justification Report and Supporting Analyses
  - 550.06 Report Organization and Appendices
  - 550.07 Updating an IJR
  - 550.08 Documentation
- Chapter 560 Fencing**
- 560.01 General
  - 560.02 References
  - 560.03 Design Criteria
  - 560.04 Fencing Types
  - 560.05 Gates
  - 560.06 Procedure
  - 560.07 Documentation
- Division 6 – Soils and Paving**
- Chapter 610 Investigation of Soils, Rock, and Surfacing Materials**
- 610.01 General
  - 610.02 References
  - 610.03 Materials Sources
  - 610.04 Geotechnical Investigation, Design, and Reporting
  - 610.05 Use of Geotechnical Consultants
  - 610.06 Geotechnical Work by Others
  - 610.07 Surfacing Report
  - 610.08 Documentation
- Chapter 620 Design of Pavement Structure**
- 620.01 General
  - 620.02 Estimating Tables



- Chapter 630 Geosynthetics**  
630.01 General  
630.02 References  
630.03 Geosynthetic Types and Characteristics  
630.04 Geosynthetic Function Definitions and Applications  
630.05 Design Approach for Geosynthetics  
630.06 Design Responsibility  
630.07 Documentation

## **Division 7 – Structures**

- Chapter 700 Project Development Roles and Responsibilities for Projects With Structures**  
700.01 General  
700.02 Procedures
- Chapter 710 Site Data for Structures**  
710.01 General  
710.02 References  
710.03 Required Data for All Structures  
710.04 Additional Data for Waterway Crossings  
710.05 Additional Data for Grade Separations  
710.06 Additional Data for Widening  
710.07 Documentation
- Chapter 720 Bridges**  
720.01 General  
720.02 References  
720.03 Bridge Locations  
720.04 Bridge Site Design Elements  
720.05 Documentation
- Chapter 730 Retaining Walls and Steep Reinforced Slopes**  
730.01 General  
730.02 References  
730.03 Design Principles  
730.04 Design Requirements  
730.05 Guidelines for Wall/Slope Selection  
730.06 Design Responsibility and Process  
730.07 Documentation
- Chapter 740 Noise Barriers**  
740.01 General  
740.02 References  
740.03 Design  
740.04 Procedures  
740.05 Documentation

## **Division 8 – Hydraulics**

- Chapter 800 Hydraulic Design**  
800.01 General  
800.02 References  
800.03 Hydraulic Considerations  
800.04 Safety Considerations  
800.05 Design Responsibility  
800.06 Documentation

---

## Division 9 – Roadside Development

- Chapter 900 Roadside Development**
  - 900.01 General
  - 900.02 References
  - 900.03 Legal Requirements
  - 900.04 Roadside Classification Plan
  - 900.05 Roadside Manual
  - 900.06 Project Development
  - 900.07 Documentation
  
- Chapter 910 Contour Grading**
  - 910.01 General
  - 910.02 References
  - 910.03 Procedures
  - 910.04 Recommendations
  - 910.05 Documentation
  
- Chapter 920 Vegetation**
  - 920.01 General
  - 920.02 References
  - 920.03 Discussion
  - 920.04 Design Guidelines
  - 920.05 Documentation
  
- Chapter 930 Irrigation**
  - 930.01 General
  - 930.02 References
  - 930.03 Design Considerations
  - 930.04 Documentation
  
- Chapter 940 Soil Bioengineering**
  - 940.01 General
  - 940.02 References
  - 940.03 Uses for Soil Bioengineering
  - 940.04 Design Responsibilities and Considerations
  - 940.05 Documentation
  
- Chapter 950 Public Art**
  - 950.01 General
  - 950.02 References
  - 950.03 Definitions
  - 950.04 Standard Architectural Design
  - 950.05 Criteria for Public Art
  - 950.06 Process and Project Delivery Timing
  - 950.07 Approvals
  - 950.08 Documentation

## Division 10 – Traffic Safety Elements

### Chapter 1010 Work Zone Safety and Mobility

- 1010.01 General
- 1010.02 References
- 1010.03 Definitions
- 1010.04 Work Zone Safety and Mobility
- 1010.05 Transportation Management Plans and Significant Projects
- 1010.06 Work Zone TMP Strategy Development
- 1010.07 Capacity Analysis
- 1010.08 Work Zone Design Standards
- 1010.09 Temporary Traffic Control Devices
- 1010.10 Other Traffic Control Devices or Features
- 1010.11 Traffic Control Plan Development and PS&E
- 1010.12 Training and Resources
- 1010.13 Documentation

### Chapter 1020 Signing

- 1020.01 General
- 1020.02 References
- 1020.03 Design Components
- 1020.04 Overhead Installation
- 1020.05 State Highway Route Numbers
- 1020.06 Mileposts
- 1020.07 Guide Sign Plan
- 1020.08 Documentation

### Chapter 1030 Delineation

- 1030.01 General
- 1030.02 References
- 1030.03 Definitions
- 1030.04 Pavement Markings
- 1030.05 Guideposts
- 1030.06 Barrier Delineation
- 1030.07 Object Markers
- 1030.08 Wildlife Warning Reflectors
- 1030.09 Documentation

### Chapter 1040 Illumination

- 1040.01 General
- 1040.02 References
- 1040.03 Definitions
- 1040.04 Design Considerations
- 1040.05 Required Illumination
- 1040.06 Additional Illumination
- 1040.07 Design Criteria
- 1040.08 Documentation

### Chapter 1050 Intelligent Transportation Systems

- 1050.01 General
- 1050.02 References
- 1050.03 Systems Engineering
- 1050.04 Documentation



110-1	Design Documentation Sequence for a Typical Design-Build Project
120-1	Relationship Between Transportation Plans and Planning Organizations
120-2	Transportation Improvement Programs
120-3	Linking Planning and Programming
130-1	Program Elements: Highway Preservation
130-2	Program Elements: Highway Improvement
130-3	Highway System Plan Implementation
210-1	Types of Public Hearings
210-2	Public Hearing Formats
210-3	Prehearing Packet Checklist
210-4	Sequence for Corridor, Design, and Environmental Hearings
210-5	Sequence for Limited Access Hearing
210-6	Hearing Summary Approvals
300-1	Design Matrix Documentation Requirements
300-2	Design Approval Level
300-3	Approvals
300-4	PS&E Process Approvals
300-5	Evaluate Upgrade (EU) Documentation Contents List
300-6	Deviation Request and Project Analysis Contents List
300-7	Design to Construction Transition Project Turnover Checklist Example
305-1	WSDOT Project Management Process
310-1	Seven-Phase Job Plan for VE Studies
310-2	VE Analysis Team Tools
320-1	Measures of Effectiveness by Facility Type
400-1	Interagency Agreement
400-2	Report of Survey Mark Example
410-1	Monument Documentation Summary
410-2	DNR Permit Application
410-3	DNR Completion Report Form
410-4	Land Corner Record
510-1	Appraisal and Acquisition
520-1	Access Control Vocabulary
530-1a	Full Access Control Limits: Interchange
530-1b	Full Access Control Limits: Interchange
530-1c	Full Access Control Limits: Interchange With Roundabouts

---

530-1d	Full Access Control Limits: Ramp Terminal With Transition Taper
530-1e	Full Access Control Limits: Single Point Urban Interchange
530-2a	Partial Access Control Limits: At-Grade Intersections
530-2b	Partial Access Control Limits: Roundabout Intersections
530-3a	Modified Access Control Limits: Roundabout Intersections
530-3b	Modified Access Control Limits: Intersections
540-1	Minimum Corner Clearance: Distance From Access Connection to Public Road or Street
540-2	Managed Access Highway Class Description
550-1	Interstate Routes: Interchange Justification Report Content and Review Levels
550-2	Non-Interstate Routes: IJR Content and Review Levels
550-3	Interstate IJR: Process Flow Chart
550-4	Non-Interstate IJR: Process Flow Chart
550-5	IJR: Stamped Cover Sheet Example
610-1	Materials Source Development
620-1	Estimating: Miscellaneous Tables
620-2a	Estimating: Hot Mix Asphalt Pavement and Asphalt Distribution Tables
620-2b	Estimating: Asphalt Distribution Tables
620-3	Estimating: Bituminous Surface Treatment
620-4	Estimating: Base and Surfacing Typical Section Formulae and Example
620-5a	Estimating: Base and Surfacing Quantities
620-5b	Estimating: Base and Surfacing Quantities
620-5c	Estimating: Base and Surfacing Quantities
620-5d	Estimating: Base and Surfacing Quantities
620-5e	Estimating: Base and Surfacing Quantities
620-5f	Estimating: Base and Surfacing Quantities
620-5g	Estimating: Base and Surfacing Quantities
620-5h	Estimating: Base and Surfacing Quantities
630-1	Selection Criteria for Geotextile Class
630-2	Maximum Sheet Flow Lengths for Silt Fences
630-3	Maximum Contributing Area for Ditch and Swale Applications
630-4	Design Process for Drainage and Erosion Control: Geotextiles and Nonstandard Applications
630-5	Design Process for Separation, Soil Stabilization, and Silt Fence
630-6	Examples of Various Geosynthetics
630-7	Geotextile Application Examples
630-8	Definition of Slope Length
630-9	Definition of Ditch or Swale Storage Length and Width
630-10	Silt Fences for Large Contributing Area
630-11	Silt Fence End Treatment

---

630-12	Gravel Check Dams for Silt Fences
700-1	Determination of the Roles and Responsibilities for Projects With Structures: Project Development Phase
710-1	Bridge Site Plan Scales
710-2	Bridge Site Data Checklist
720-1	Bridge Vertical Clearances
720-2	Highway Structure Over Railroad
720-3	Embankment Slope at Bridge Ends
720-4	Phased Development of Multilane Divided Highways
730-1	Summary of Mechanically Stabilized Earth (MSE) Gravity Wall/Slope Options Available
730-2	Summary of Prefabricated Modular Gravity Wall Options Available
730-3	Summary of Rigid Gravity and Semigravity Wall Options Available
730-4	Summary of Nongravity Wall Options Available
730-5	Summary of Anchored Wall Options Available
730-6	Other Wall/Slope Options Available
730-7	Typical Mechanically Stabilized Earth Gravity Walls
730-8	Typical Prefabricated Modular Gravity Walls
730-9	Typical Rigid Gravity, Semigravity Cantilever, Nongravity Cantilever, and Anchored Walls
730-10	Typical Rockery and Reinforced Slopes
730-11	MSE Wall Drainage Detail
730-12	Retaining Walls With Traffic Barriers
730-13a	Retaining Wall Design Process
730-13b	Retaining Wall Design Process: Proprietary
740-1	Standard Noise Wall Types
900-1	Funding Source Determines Extent of Restoration
940-1	Soil Bioengineering Design
1010-1	General Lane Closure Work Zone Capacity
1010-2	Minimum Work Zone Clear Zone Distance
1010-3	Transportation Management Plan Components Checklist
1020-1	Reflective Sheeting Requirements for Overhead Signs
1020-2	Timber Posts
1020-3	Wide Flange Steel Posts
1020-4	Laminated Wood Box Posts
1030-1	Pavement Marking Material Guide
1030-2	Guidepost Placement
1040-1a	Freeway Lighting Applications
1040-1b	Freeway Lighting Applications
1040-1c	Freeway Lighting Applications
1040-2	Freeway Ramp Terminals

1040-3	Ramp With Meter
1040-4	Freeway-to-Freeway Connection
1040-5	HOT (High-Occupancy Toll) Lane Enter/Exit Zone
1040-6	Lane Reduction
1040-7	Add Lane
1040-8a	Intersection With Left-Turn Channelization: Divided Highway
1040-8b	Intersections With Left-Turn Channelization
1040-9	Intersections With Drop Lane/Right-Turn Lane Channelization
1040-10	Intersections With Traffic Signals
1040-11	Intersection Without Channelization
1040-12	Roundabout
1040-13	Railroad Crossing With Gates or Signals
1040-14	Midblock Pedestrian Crossing
1040-15	Transit Flyer Stop
1040-16	Major Parking Lot
1040-17	Minor Parking Lot
1040-18	Truck Weigh Site
1040-19	Safety Rest Area
1040-20	Chain-Up/Chain-Off Parking Area
1040-21	Tunnel
1040-22	Bridge Inspection Lighting System
1040-23	Traffic Split Around an Obstruction
1040-24	Construction Work Zone and Detour
1040-25	Light Levels and Uniformity Ratios
1050-1	Systems Engineering Process (“V” Diagram)
1050-2	ITS Project Systems Engineering Review Form (With Instructions)



- 100.01 Purpose
- 100.02 Presentation and Revisions
- 100.03 Manual Applications
- 100.04 Manual Use
- 100.05 Manual Organization

## 100.01 Purpose

The Washington State Department of Transportation (WSDOT) has developed the *Design Manual* to reflect policy, outline a uniformity of methods and procedures, and communicate vital information to its employees and others who develop projects on state highways. When properly used, the manual will facilitate the development of a highway system consistent with the needs of the multi-modal traveling public.

WSDOT designers are required to comply with the *Design Manual*. The Federal Highway Administration (FHWA) has agreed to approve designs that follow guidance in the *Design Manual*; therefore, adherence to the guidance presented is not optional for state highway projects.

The information, guidance, and references contained herein are not intended as a substitute for sound engineering judgment. The *Design Manual* is not a comprehensive textbook on highway engineering, nor does it attempt to cover all the possible scenarios Washington's highways present. It is recognized that some situations encountered are beyond the scope of this presentation.

If you have design questions not answered by the *Design Manual*, contact the Headquarters (HQ) Design Office.

## 100.02 Presentation and Revisions

The *Design Manual* is available on the Internet. It can be accessed through the:

- WSDOT Home Page:  
🔗 [www.wsdot.wa.gov/](http://www.wsdot.wa.gov/)
- Design Policy Web Page:  
🔗 [www.wsdot.wa.gov/design/policy/](http://www.wsdot.wa.gov/design/policy/)
- Active *Design Manual* Revisions Web Page:  
🔗 [www.wsdot.wa.gov/design/manual/activerevisions.htm](http://www.wsdot.wa.gov/design/manual/activerevisions.htm)
- Publications Services Web Page:  
🔗 [www.wsdot.wa.gov/publications/manuals/index.htm](http://www.wsdot.wa.gov/publications/manuals/index.htm)

The online version of the manual enables you to conduct a word search of the entire manual. Opening an individual chapter is faster, but a word search is limited to that chapter.

The *Design Manual* is continually revised to reflect changing processes, procedures, regulations, policies, and organizations. Feedback from users is encouraged to improve the manual for everyone. Comments may be submitted by any method that is convenient for you. There is a comment form in the front of the manual, or comments may be made via the contact names on the Design Policy Internet page (see link above). Note that the Design Policy Internet page includes a link to an errata page, which provides a list of known technical errors in the manual. Manual users are encouraged to view this page on a regular basis.

A contents section lists all chapters and the major headings of the sections/pages. The exhibits section lists all the exhibits in the manual.

Most chapters include a list of references, including laws, administrative codes, manuals, and other publications, which are the basis for the information in the chapter. The definitions for the *Design Manual* are found in the [Glossary](#).

### 100.03 Manual Applications

*Design Manual* guidance is provided to encourage the statewide uniform application of design details under normal conditions. It also guides designers through the project development process used by WSDOT. The *Design Manual* is used by the department to:

- Interpret current design principles, including American Association of State Highway and Transportation Officials (AASHTO) policy and federal and state laws.
- Develop projects that meet drivers' expectations.
- Balance the benefits and costs of highway construction projects.

The *Design Manual* is designed to allow for flexibility in design for specific and unusual situations. For unusual circumstances, the manual provides mechanisms for documenting the reasons for the choices made.

The *Design Manual* is developed for use on Interstate and state highways and may not be suitable for projects on county roads or city streets.

### 100.04 Manual Use

The WSDOT *Design Manual* is intended to be used for design of department-owned facilities, especially the transportation facilities associated with state highways as designated by [RCW 47.17](#).

For state highway routes, all projects must be designed using the *Design Manual* geometric control criteria (see [Chapter 1100](#) and Division 11). If WSDOT guidance is not used on a project, appropriate documentation and approvals are required (see Chapters [300](#) and [1100](#)).

When WSDOT designs facilities that will be turned over to local jurisdictions, those facilities are to be designed using appropriate local geometric design criteria.

When local jurisdictions design any element of state highway facilities, the *Design Manual* must be used. Local jurisdictions are free to adopt this manual for their local criteria or to develop their own specialized guidance for facilities not on state highway routes.

## 100.05 Manual Organization

The *Design Manual* is split into the following two volumes:

- Volume 1 contains *procedural topics*, including project documentation, permitting and hearings, site data, project investigation, and guidance for coordination with specialty group functions such as traffic, right of way, bridge and structures, and geotechnical design.
- Volume 2 addresses *design criteria and geometrics*. The design matrices are included in this volume because they communicate expectations for which elements are included in projects.

Each volume is divided into a series of divisions that address a portion of the project development and design processes. The divisions are comprised of chapters that address the general topic in detail and are, in some cases, specific to a particular discipline.

### 100.05(1) Volume 1: Procedures

**Division 1 – General Information:** Presents general background on planning, managing project delivery, project development, and programming.

- **Chapter 100 – Manual Description:** Chapter content/resources within the *Design Manual*.
- **Chapter 110 – Design-Build Projects:** How the *Design Manual* applies to design-build projects: includes terminology and reference to design-build contract documents.
- **Chapter 120 – Planning:** Critical information, such as corridor studies and route development plans, relating to the corridor in which the project resides.
- **Chapter 130 – Project Development Sequence:** The project development sequence from the Washington Transportation Plan through the contract document: emphasizes the Project Summary and Change Management process.

**Division 2 – Hearings, Environmental, and Permits:** Provides the designer with information about the public involvement and hearings process, the environmental documentation process, and the permit process.

- **Chapter 210 – Public Involvement and Hearings:** Developing a project-specific public involvement plan; the ingredients of an effective public involvement plan; and methods for public involvement.
- **Chapter 225 – Environmental Coordination:** Provides a summary of the relevant provisions in the *Environmental Procedures Manual*. Gives designers a brief overview and direction to environmental resources.

**Division 3 – Project Documentation:** Provides designers with information on value engineering, traffic analysis, design documentation, and approvals.

- **Chapter 300 – Design Documentation, Approval, and Process Review:** Building the Project File (PF) and the Design Documentation Package (DDP) and recording the recommendations and decisions that lead to a project by preserving the documents from the planning, scoping, programming, and design phases (includes permits, approvals, contracts, utility relocation, right of way, advertisement and award, and construction).
- **Chapter 305 – Managing Projects:** Brief description and links to WSDOT design and project development resources.
- **Chapter 310 – Value Engineering:** A systematic, multidisciplinary process study early in the project design stage to provide recommendations to improve scope, functional design, constructability, environmental impacts, or project cost—required by federal law for high-cost, complex projects.

- **Chapter 320 – Traffic Analysis:** Procedural guidance and general requirements for conducting traffic analyses.

**Division 4 – Surveying:** Includes criteria for surveying, mapping, and monumentation requirements.

- **Chapter 400 – Surveying and Mapping:** The procedures within WSDOT for project surveying.
- **Chapter 410 – Monumentation:** The requirements and procedures for Monumentation.

**Division 5 – Right of Way and Access Control:** Provides guidance on right of way considerations; interchange justification reports; limited/managed access; and fencing.

- **Chapter 510 – Right of Way Considerations:** The right of way and easement acquisition process.
- **Chapter 520 – Access Control:** WSDOT Access Control program information.
- **Chapter 530 – Limited Access Control:** Clarification on full, partial, and modified limited access control.
- **Chapter 540 – Managed Access Control:** The classes of managed access highways and the access connection permitting process.
- **Chapter 550 – Interchange Justification Report:** The process for access point revisions on limited access controlled highways and the steps for producing an interchange justification report.
- **Chapter 560 – Fencing:** The purpose of fencing, types of fencing, and fencing design criteria.

**Division 6 – Soils and Paving:** Presents guidance for investigating soils, rock, and surfacing materials; estimating tables; and guidance and criteria for the use of geosynthetics.

- **Chapter 610 – Investigation of Soils, Rock, and Surfacing Materials:** The requirements for qualifying a materials source, geotechnical investigations, and the documentation to be included in the Project File.
- **Chapter 620 – Design of Pavement Structures:** Estimating tables for the design of pavement structures.
- **Chapter 630 – Geosynthetics:** The types/applications of geosynthetic drainage, earthwork, erosion control, and soil reinforcement materials.

**Division 7 – Structures:** Provides guidance for the design of structures for highway projects, including site data for structures, bridges, retaining walls, and noise walls.

- **Chapter 700 – Project Development Roles and Responsibilities for Projects With Structures:** WSDOT's project development process: roles and responsibilities for projects with structures during the project development phase of a project.
- **Chapter 710 – Site Data for Structures:** Information required by the HQ Bridge and Structures Office to provide structural design services.
- **Chapter 720 – Bridges:** Basic design considerations for developing preliminary bridge plans and guidelines on basic bridge geometric features.

- **Chapter 730 – Retaining Walls and Steep Reinforced Slopes:** Design principles, requirements, and guidelines for retaining walls and steep reinforced slopes.
- **Chapter 740 – Noise Barriers:** Factors considered when designing a noise barrier.

**Division 8 – Hydraulics:** Addresses the issue of hydraulics and serves as a guide to highway designers to identify and consider hydraulic-related factors that may impact the design.

- **Chapter 800 – Hydraulic Design:** Hydraulic considerations for highway projects involving flood plains, stream crossings, channel changes, and groundwater.

**Division 9 – Roadside Development:** Provides guidance on the portion of state highways between the traveled way and the right of way boundary.

- **Chapter 900 – Roadside Development:** Managing the roadside environment, including the area between the traveled way and the right of way boundary, unpaved median strips, and auxiliary facilities such as rest areas, wetlands, and stormwater treatment facilities.
- **Chapter 910 – Contour Grading:** Contour grading to achieve operational, environmental, and visual functions.
- **Chapter 920 – Vegetation:** The use of vegetation in the roadside environment and when to contact the Landscape Architect.
- **Chapter 930 – Irrigation:** Design considerations for irrigation on highway projects.
- **Chapter 940 – Soil Bioengineering:** Design considerations for the use of bioengineering techniques on highway projects.
- **Chapter 950 – Public Art:** Policies and procedures for including public art in state transportation corridors.

**Division 10 – Traffic Safety Elements:** Introduces the designer to traffic safety elements such as work zone traffic control, signing, delineation, illumination, traffic control signals, and Intelligent Transportation Systems (ITS).

- **Chapter 1010 – Work Zone Safety and Mobility:** Planning, design, and preparation of highway project plans that address work zone safety and mobility requirements.
- **Chapter 1020 – Signing:** The use of signing to regulate, warn, and guide motorists.
- **Chapter 1030 – Delineation:** The use of pavement markings to designate safe traffic movement.
- **Chapter 1040 – Illumination:** Illumination design on state highway construction projects.
- **Chapter 1050 – Intelligent Transportation Systems (ITS):** Applying computer and communication technology to optimize the safety and efficiency of the highway system.

### **100.05(2) Volume 2: Design Criteria**

**Division 11 – Project Design Criteria:** Provides design criteria guidance for basic design, modified design, and full design that are part of the design matrices in [Chapter 1100](#).

- **Chapter 1100 – Design Matrix Procedures:** Includes design matrices that provide consistency across projects according to funding type and highway system. Each design matrix sets forth the design levels for a given type of need, which would be automatically approved by the department and FHWA. The chapter also discusses deviation approvals and how to apply the appropriate design level for the majority of Improvement and Preservation projects.

- **Chapter 1110 – Minor Operational Enhancement Projects:** Design matrices for low-cost, quick-fix projects that improve the operation of a state highway facility.
- **Chapter 1120 – Basic Design Level:** The required basic safety work and minor preservation and safety work included in the preservation of pavement structures and pavement service life while maintaining safe operation of the highway.
- **Chapter 1130 – Modified Design Level:** Design guidance unique to the modified design level of preserving and improving existing roadway geometrics and safety and operational elements.
- **Chapter 1140 – Full Design Level:** Guidance for the highest level of highway design, used on new and reconstructed highways to improve roadway geometrics and safety and operational elements.

**Division 12 – Geometrics:** Covers geometric plan elements; horizontal alignment; lane configurations and pavement transitions; geometric profile elements; vertical alignment; geometric cross sections; and sight distance.

- **Chapter 1210 – Geometric Plan Elements:** The design of horizontal alignment, lane configuration, and pavement transitions.
- **Chapter 1220 – Geometric Profile Elements:** The design of vertical alignment.
- **Chapter 1230 – Geometric Cross Section:** Roadway width and roadside slope design.
- **Chapter 1240 – Turning Roadways:** Widening curves to make the operating conditions comparable to those on tangent sections.
- **Chapter 1250 – Superelevation:** Superelevating curves and ramps so design speeds can be maintained.
- **Chapter 1260 – Sight Distance:** Stopping, passing, and decision sight distance design elements.
- **Chapter 1270 – Auxiliary Lanes:** Auxiliary facilities such as climbing lanes, passing lanes, slow-vehicle turnouts, shoulder driving for slow vehicles, emergency escape ramps, and chain-up areas.

**Division 13 – Intersections and Interchanges:** Addresses the design considerations of at-grade intersections, roundabouts, road approaches, railroad grade crossings, and traffic interchanges.

- **Chapter 1300 – Intersection Control Type:** Guidance on preliminary intersection analysis and selection of control type.
- **Chapter 1310 – Intersections:** Designing intersections at grade, including at-grade ramp terminals.
- **Chapter 1320 – Roundabouts:** Guidance on the design of roundabouts.
- **Chapter 1330 – Traffic Control Signals:** The use of power-operated traffic control devices that warn or direct traffic.
- **Chapter 1340 – Driveways:** The application and design of road approaches on state highways.
- **Chapter 1350 – Railroad Grade Crossings:** The requirements for highways that cross railroads.
- **Chapter 1360 – Traffic Interchanges:** The design of interchanges on interstate highways, freeways, and other multilane divided routes.

- **Chapter 1370 – Median Crossovers:** Guidance on locating and designing median crossovers for use by maintenance, traffic service, emergency, and law enforcement vehicles.

**Division 14 – HOV and Transit:** Provides design guidance on HOV lanes and transit facilities.

- **Chapter 1410 – High-Occupancy Vehicle Facilities:** Evaluating and designing high-occupancy vehicle (HOV) facilities.
- **Chapter 1420 – HOV Direct Access:** Design guidance on left-side direct access to HOV lanes and transit facilities.
- **Chapter 1430 – Transit Benefit Facilities:** Operational guidance and information for designing transit facilities such as park & ride lots, transfer/ transit centers, and bus stops and pullouts.

**Division 15 – Pedestrian and Bicycle Facilities:** Provides guidance on pedestrian and bicycle facility design.

- **Chapter 1510 – Pedestrian Facilities:** Designing facilities that encourage efficient pedestrian access that meets ADA.
- **Chapter 1515 – Shared-Use Paths:** Guidance that emphasizes pedestrians are users of shared-use paths and accessibility requirements apply in their design.
- **Chapter 1520 – Roadway Bicycle Facilities:** Selecting and designing useful and cost-effective bicycle facilities.

**Division 16 – Roadside Safety Elements:** Addresses design considerations for the area outside the roadway, and includes clear zone, roadside hazards, safety mitigation, traffic barriers, and impact attenuator systems.

- **Chapter 1600 – Roadside Safety:** Clear zone design, roadside hazards to consider for mitigation, and some roadside safety features.
- **Chapter 1610 – Traffic Barriers:** Design of traffic barriers based on the design levels identified in the design matrices.
- **Chapter 1620 – Impact Attenuator Systems:** Permanent and work zone impact attenuator systems.

**Division 17 – Roadside Facilities:** Provides design guidance for the area outside the roadway, including rest areas and truck weigh sites.

- **Chapter 1710 – Safety Rest Areas and Traveler Services:** Typical layouts for safety rest areas.
- **Chapter 1720 – Weigh Sites:** Guidance on designing permanent, portable, and shoulder-sited weigh sites.





Funding agencies often give preference to jointly sponsored transportation projects. RTPOs and MPOs can develop jointly sponsored projects since they represent multiple agencies. Major projects backed by an RTPO or an MPO have a better chance of receiving funding.

### **(3) Development of the STIP**

An important role of the WSDOT Highways and Local Programs Division is to combine all RTIP, MTIP, and HSP projects in appropriate years, and all of the state and federally funded projects and projects of regional significance, into the (three-year) Statewide Transportation Improvement Program (STIP).

Development of a new STIP every two years is required by federal law in order to expend federal transportation dollars. The state of Washington, however, develops a new STIP each year to enhance project flexibility and ensure project delivery.

The Governor's approval of the MTIPs, plus the FHWA's and the FTA's approval of the STIP, are required prior to expenditure of federal funds.

## **120.07 Linking WSDOT Planning to Programming**

[Exhibit 120-3](#) is a flowchart describing the process conceptual solutions must go through to receive funding. This chart also describes the link between planning and program development. (For more information, see [Chapter 300](#) for project definition, [Chapter 1100](#) for design matrices, and [Chapter 225](#) for environmental documentation.)

### **(1) The Role of the Systems Analysis and Program Development Branch**

The WSDOT planning process determines *what* facilities or services will be provided *where*. The role of WSDOT Systems Analysis and Program Development Branch is to determine *when* the improvements will be implemented. The WSDOT Systems Analysis and Program Development Branch prioritizes the projects that are selected from the State Highway System Plan component of the Washington Transportation Plan (see [120.04\(2\)\(a\)1](#)).

Taking the HSP from the planning stage through the programming stage is another role of the Systems Analysis and Program Development Branch. The Systems Analysis and Program Development Branch and the Project Control and Reporting Office manage the statewide highway construction program, including:

- Recommending subprogram funding levels.
- Developing project priorities.
- Preparing, executing, and monitoring the highway construction program.

The Systems Analysis and Program Development Branch is responsible for the oversight of the *Programming Process*. The legislative authorization for this activity is in [RCW 47.05](#), Priority Programming. The Programming Process describes how projects that have been identified in the HSP are prioritized.

### **(2) Subprogram Categories**

Subprogram categories for the service objectives and action strategies have been established within WSDOT's budget to allow decision makers to determine timing and the amount of money to invest in meeting transportation needs. (See the HSP for the service objectives and action strategies.)

The order of needs within each subprogram category is usually prioritized based on benefit/cost methodology; however, some subprograms do not have a prioritization methodology attached to them (such as Economic Initiatives).

The department may combine projects that are scheduled to be constructed within six years of each other to eliminate projects at the same location just a few years apart.

Following completion of construction, WSDOT evaluates the effectiveness of the project on the performance of the transportation system.

### **(3) WSDOT Budgets**

WSDOT uses the State Highway System Plan component of the twenty-year Washington Transportation Plan as the basis for prioritizing and programming to select projects for the Agency Request Budget (ARB) and Current Law Budget (CLB). To be selected, a project must already be included in the HSP.

WSDOT operates on a two-year funding cycle. This is primarily because the state Legislature appropriates state transportation funds on a biennial basis. The Washington State Transportation Commission recommends a Six-Year Plan Element and the ten-year Capital Improvement and Preservation Program (CIPP). The plans are developed to better implement the federal and state laws influencing transportation and land use; to encourage a longer-range perspective in the funding of transportation projects; and to be consistent with local and regional transportation planning processes. These plan elements are used to develop the two-year budget proposals.

When appropriated by the Legislature, WSDOT's two-year budget is forwarded to the appropriate RTPOs and MPOs for any needed revisions to the RTIPs and MTIPs.

### **(4) Key Points of Planning and Programming at WSDOT**

Following is a list of key points to remember about WSDOT's planning and programming processes:

- Executive policy sets the direction for the WTP.
- Federal transportation laws and state transportation and land use laws guide solutions to address the needs for transportation facilities and services.
- The WTP is developed in partnership with MPOs and RTPOs and is tied to the land use plans of towns, cities, and counties.
- Region Planning offices are responsible for meeting many of the state and federal planning requirements.
- The SHSP is a component of the WTP.
- The SHSP sets forth service objectives and action strategies.
- Conceptual solutions are prioritized within most budget categories based on benefit/cost analyses to obtain the greatest benefit at the least cost.
- Tradeoffs between project categories are made by policy choice through a multitiered process.
- An improvement strategy must be listed in the HSP to be considered for project funding.

**(e) Categories of Work**

The HSP presents the budgets for the Maintenance (M), Operations (Q), Preservation (P), and Improvement (I) programs. Strategies and conceptual solutions are limited to the Preservation and Improvement programs. Each of these programs is divided into subprograms, as shown in the [Exhibits 130-1](#) and [130-2](#).

**(3) Project Summary**

The Project Summary is developed in the region when a project is proposed for programming. The intent of the Project Summary is to initiate the development of a project by identifying the need that generated the project and the proposed solution to solve that need.

The regions prepare the Project Summary during project scoping. The information provided guides the project through the design process to project approval.

The Project Summary:

- Defines the purpose and need for the project and spells out the scope of work.
- Includes a cost/benefit measure to determine the project's cost-effectiveness.
- Documents the design decisions or assumptions that the region made while determining the project scope.
- Identifies the major factors that will influence the scope, schedule, and budget and includes a cost increase factor for unidentified risks.
- Establishes initial preliminary engineering, right of way, and construction cost estimates.
- Documents the project delivery schedule.
- Requires approval by the HQ SA&PD Section prior to submittal to the Legislature for programming consideration.
- Documents the potential environmental impacts and permits that may be required.

Regions are encouraged to place special emphasis on project scoping, estimating, and scheduling during program development as a means to verify that program delivery stays within the appropriated dollars and workforce. Resources available to the regions include: Highway System Plan; route development plans, and other approved corridor studies; Design Matrices; [Roadside Classification Plan](#); Environmental Workbench and other planning; and design and environmental documents to ensure project scoping is consistent.

The initial environmental classification and documentation required for the project is established in the Environmental Review Summary (ERS) section of the Project Summary. Environmental classification at the Project Summary stage has several benefits. It helps clarify the impacts associated with a project and also helps to establish a realistic schedule and PE cost estimate. All projects require supporting State Environmental Policy Act (SEPA) documentation. For projects eligible for federal funding, National Environmental Policy Act (NEPA) documentation is also required.

When scoping projects, regions are encouraged to take full advantage of expertise available from the HQ Systems Analysis and Program Development (SA&PD) Section of the Strategic Planning and Programming Division, FHWA, the HQ Environmental Services Office, and local agencies. These resources can help the regions evaluate a project's impacts and provide the appropriate project direction. They will also help ensure all aspects are considered and the proposed solution is eligible for available funding.

The HQ SA&PD Section coordinates review of the Project Summary and forwards any comments to the regions for resolution prior to approval. Once all comments and outstanding issues are resolved, the Project Summary can be approved and copies distributed.

#### **(4) Environmental Document**

The environmental document is a statement that identifies impacts to the natural and constructed environment as a result of a project and its potential mitigation. The statement may consist of one or two pages for categorically exempted projects, a SEPA Checklist, Documented Categorical Exclusion (DCE), or an Environmental Assessment (EA) or Environmental Impact Statement (EIS) for major projects (see [Chapter 225](#)).

#### **(5) Design Documentation Package (DDP)**

The DDP, which is a portion of the Project File, is a formal document of design decisions and conclusions reached in the development of a project. The Project File records various design recommendations that are reviewed within the department and, when approved, become the project design (see [Chapter 300](#)).

#### **(6) Right of Way/Limited Access Plans**

Right of way/limited access plans are the official state documents used to acquire real estate, property, and access rights. These plans determine rights of access from abutting property owners, interchange/intersection spacing, access points per mile, or other selective approaches to a highway facility. Right of way plans are used to obtain the "Order of Public Use and Necessity," which is the authority to acquire real property and property rights under eminent domain.

The establishment of limited access control is considered whenever major improvements, reconstruction, relocation, significant new rights of way, or new facilities are required. (See Chapters 520, 530, and 540, and the [Plans Preparation Manual](#) for more information.)

#### **(7) Contract Documents**

The contract Plans, Specifications, and Estimates (PS&E) are the final documents needed for the advertisement of a construction contract. Contract plans conform to the basic design features approved in the Project Summary, environmental documents, and Design Documentation Package. Present the work in the plans and contract specifications in a clear and concise manner to avoid misinterpretation. A tool available to the designer to check whether required items are addressed during the PS&E preparation is the "PS&E Review Checklist," available at: [www.wsdot.wa.gov/design/projectdev/](http://www.wsdot.wa.gov/design/projectdev/). Projects may go through PS&E preparation, but they will not be advertised for construction until the required work and approvals are complete (see the [Plans Preparation Manual](#)).

210.01	General
210.02	References
210.03	Definitions
210.04	Public Involvement
210.05	Public Hearings
210.06	Environmental Hearing
210.07	Corridor Hearing
210.08	Design Hearing
210.09	Limited Access Hearing
210.10	Combined Hearings
210.11	Administrative Appeal Hearing
210.12	Follow-Up Hearing
210.13	Documentation

### 210.01 General

The Washington State Department of Transportation (WSDOT) strives to keep the public informed about transportation issues, involve the public in transportation decision making, and make transportation decisions based on the public's best interests.

One of the best ways to achieve WSDOT's goals is to collaborate with the public, community groups, and various agencies. These participants often have differing, and sometimes conflicting, perspectives and interests. In addition, many participants and organizations are not able to spend the time and effort required to fully engage in transportation decision making. Despite these challenges, active collaboration:

- Gives WSDOT access to important information and new ideas.
- Puts us in a position to help solve problems and resolve conflicts.
- Creates a sense of community.
- Fosters greater acceptance of projects.
- Helps us build and sustain a credible and trusting relationship with the public.
- Ultimately leads to transportation improvements that better meet the public's needs and desires.

When collaborating with the public about transportation projects or issues, WSDOT uses more formal techniques like public hearings, direct mail, and presentations to city councils and legislators; as well as less formal but equally important techniques, like telephone and e-mail discussions, meetings with community groups, media relations, and project Internet pages.

Law requires that many types of capital transportation projects go through a formal public hearing process; thus, the legal procedures necessary for public hearings is the primary focus of this chapter. Public involvement plans are briefly discussed, and referrals to WSDOT's communications resources are included to further guide their development and implementation.

## 210.02 References

### (1) Federal/State Laws and Codes

United States Code (USC) Title 23, Highways, Sec. 128, Public hearings

USC Title 23, Highways, Sec. 771.111, Early coordination, public involvement, and project development

23 Code of Federal Regulations (CFR) 200.7, FHWA Title VI Policy

23 CFR 200.9(b)(4), Develop procedures for the collection of statistical data of participants and beneficiaries of state highway programs

23 CFR 200.9(b)(12), Develop Title VI information for dissemination to the general public

23 CFR 450.212, Public involvement

28 CFR Part 35, Nondiscrimination on the basis of disability in state and local government services

49 CFR Part 27, Nondiscrimination on the basis of disability in programs or activities receiving federal financial assistance

Americans with Disabilities Act of 1990 (ADA) (28 CFR Part 36, Appendix A)

Civil Rights Restoration Act of 1987

Executive Order 12898, Federal Actions to Address Environmental Justice in Minority Populations and Low-Income Populations

Executive Order 13166, Improving Access to Services for Persons with Limited English Proficiency

Revised Code of Washington (RCW) 47.50, Highway Access Management

RCW 47.52, Limited Access Facilities

Section 504 of the Rehabilitation Act of 1973, as amended

Title VI of the Civil Rights Act of 1964

### (2) Design Guidance

*Design Manual*, Chapter 225, for environmental references, and Division 5 chapters for access control and right of way references

*Environmental Procedures Manual*, M 31-11

[www.wsdot.wa.gov/publications/manuals/m31-11.htm](http://www.wsdot.wa.gov/publications/manuals/m31-11.htm)

WSDOT Headquarters (HQ) Development Services & Access Manager, (360) 705-7251 – home page:

[www.wsdot.wa.gov/design/accessandhearings](http://www.wsdot.wa.gov/design/accessandhearings)

### (3) Supporting Information

*Improving the Effectiveness of Public Meetings and Hearings*, Federal Highway Administration (FHWA) Guidebook

**order of hearing** The official establishment of a hearing date by the Director & State Design Engineer, Development Division.

**prehearing packet** A concise, organized collection of all necessary prehearing data, prepared by the region and approved by the HQ Development Services & Access Manager prior to the hearing (see 210.05(4) and [Exhibit 210-3](#)).

**project management plan** A formal, approved document that defines how the project is executed, monitored, and controlled. It may be in summary or detailed form and may be composed of one or more subsidiary management plans and other planning documents. For further information, see the *Project Management Online Guide*: [www.wsdot.wa.gov/Projects/ProjectMgmt/Process.htm](http://www.wsdot.wa.gov/Projects/ProjectMgmt/Process.htm)

**public involvement plan** A plan to collaboratively involve the public in decision making, tailored to the specific needs and conditions of a project and the people and communities it serves. It is often part of a broader communications plan.

**relocation assistance program** A program that establishes uniform procedures for relocation assistance that will ensure legal entitlements and provide fair, equitable, and consistent treatment to persons displaced by WSDOT-administered projects, as defined in the *Right of Way Manual*.

**résumé** An official notification of action taken by WSDOT following adoption of a findings and order (see 210.09(14)).

**SEPA** State Environmental Policy Act.

**study plan** A term associated with environmental procedures, this plan proposes an outline or “road map” of the environmental process to be followed during the development of a project that requires complex NEPA documentation. (See 210.06 and the *Environmental Procedures Manual*.)

## 210.04 Public Involvement

Developing and implementing an effective plan for collaboration with the public:

- Is critical to the success of WSDOT’s project delivery effort.
- Provides an opportunity to understand and achieve diverse community and transportation goals.

Effective public involvement must begin with clearly defined, project-related goals that focus on specific issues, specific kinds of input needed, and specific people or groups that need to be involved. The more detailed a public involvement plan, the greater its chances of obtaining information WSDOT can use in decision making.

Transportation projects with high visibility or community issues or effects often attract the attention of a broad range of interested people. These types of projects will best benefit from early public involvement, which can influence the project’s success and community acceptance.

Developing a profile (through demographic analysis) of the affected community is critical to achieving successful public involvement and should be the first order of business when developing a public involvement plan. The profile will enable the department to tailor its outreach efforts toward the abilities and needs of the community.

Individuals from minority and ethnic groups and low-income households, who are traditionally underserved by transportation, often find participation difficult. While these groups form a growing portion of the population, particularly in urban areas, historically they have experienced barriers to participation in the public decision-making process and are therefore underrepresented. These barriers arise from both the historical nature of the public involvement process and from cultural, linguistic, and economic differences. For example, a community made up of largely senior citizens (with limited mobility/automobile usage) may mean:

- Meetings/open houses are planned in locations easily accessible to them, such as senior centers and neighborhood community centers.
- Meetings are scheduled in the mornings or midday to accommodate individuals who prefer not to leave home after dark.
- Meetings are scheduled in the evenings to accommodate persons who work during the day.

A project's affected area might consist of a population with limitations in speaking or understanding English. This may entail:

- Developing/disseminating materials in other languages, as appropriate.
- Having a certified translator on hand at the meetings.

Extra effort may be needed to elicit involvement from people unaccustomed to participating in the public involvement process. They often have different needs and perspectives than those who traditionally participate in transportation decision making, and they may have important, unspoken issues that should be heard. They not only may have greater difficulty getting to jobs, schools, recreation, and shopping than the population at large, but also they are often unaware of transportation proposals that could dramatically change their lives.

NEPA and SEPA environmental policies and procedures are intended to provide relevant environmental information to public officials, agencies, and citizens, and allow public input to be considered before decisions are made. There are also various other laws, regulations, and policies that emphasize public involvement, including 23 CFR, Title VI of the Civil Rights Act, the Americans with Disabilities Act, and Executive Orders 12898 and 13166.

WSDOT's collaborative process with the public should be open, honest, strategic, consistent, inclusive, and continual. Initiating a project in an atmosphere of collaboration and partnership can go a long way toward providing equal opportunities for all parties (local, state, tribal, private, nonprofit, or federal) to participate in a project vision. This collaboration requires an intensive communications effort that is initiated during project visioning and extends through construction and eventual operation of the facility.

Department specialists in public communications, environmental procedures, traffic engineering, real estate services, and limited access control are routinely involved with public outreach efforts and project hearings. Depending on the scale and complexity of a project, the region is encouraged to engage the participation of interdisciplinary experts when developing a public involvement plan and communicating project details.



**5. Statements, Plans, or Counterproposals From the Public**

Accept public views or statements regarding the proposal presented, the alternatives, and the social, economic, and environmental effects identified. Avoid evaluating the views presented while conducting the hearing.

**6. Relocation Assistance Program**

Explain the relocation assistance program and relocation assistance payments available. At all hearings, the relocation assistance brochure must be available for free distribution, including (if appropriate) brochures in languages other than English. Real Estate Services personnel should be available.

If the project does not require any relocations, the relocation assistance discussion may be omitted. Make a simple statement to the effect that relocation assistance is provided, but currently no relocations have been identified for the project. The relocation brochure and personnel should still be available to the public at the hearing.

**7. Acquisition**

Discuss right of way acquisition, estimated cost, and currently proposed construction schedules and critical activities that may involve or affect the public.

**8. Closing**

Summarize the hearing and announce proposed future actions.

**9. Adjournment**

Adjourn the hearing with sincere gratitude for the public's valuable participation.

**(10) Hearing Summary and Adoption**

Upon completion of a public hearing, a documentation and approval procedure leads to official adoption of the hearing proceedings. After the hearing, a summary is prepared by the region. There are two types of summary documents used, depending on the type of hearing. For environmental, corridor, and design hearings, a hearing summary is produced. Following a limited access hearing, a findings and order document is prepared. Each of these packages is comprised of documentation assembled by the region and approved by Headquarters.

**(a) Hearing Summary Contents**

The hearing summary includes the following elements:

1. Hearing transcript.
2. Copy of the affidavit of publication of the hearing notice.
3. Hearing material:
  - Copies of the letters received before and after the hearing.
  - Copies or photographs of, or references to, every exhibit used in the hearing.

4. Summary and analyses of all oral and written comments. Include consideration of the positive and negative social, economic, and environmental aspects of these comments.

(b) **Limited Access Hearing Findings and Order**

Following a limited access hearing, the “summary” document is labeled the findings and order. Refer to [210.09\(12\)](#) for the process description and required documentation for findings and order documents.

(c) **Adoption and Approval**

For specific hearing types, see subsequent sections in this chapter related to adoption procedures.

[Exhibit 210-6](#) identifies the Headquarters approval authority for hearing summary and findings and order documents.

## 210.06 Environmental Hearing

Early coordination with appropriate agencies and the public may help to determine the appropriate level of environmental documentation, the scope of the document, the level of analysis, and related environmental disciplines to be analyzed.

Environmental documents address the positive and negative social, economic, and environmental project effects, as described in [Chapter 225](#) and the [Environmental Procedures Manual](#). The project environmental documentation is the first step in the environmental hearing procedure. Each step of the hearing procedure is dovetailed into the environmental process and is important in achieving the appropriate project documentation. Corridor and design hearings are not normally required for Environmental Assessments, SEPA Checklists, and categorically excluded projects. However, the opportunity for an environmental hearing might be required or advisable for controversial proposals. When an environmental hearing is not required, an informational meeting may serve as a useful forum for public involvement in the environmental process. Consult with region environmental staff and the HQ Hearing Coordinator for specific project requirements.

Projects requiring an Environmental Impact Statement (EIS) must use an evaluation process called *scoping* in the NEPA and SEPA requirements. This process helps the project proponents identify the significant issues and possible alternatives analyzed and documented in the Draft EIS, and it must follow the public involvement plan included in the environmental study plan for the project.

After the project has been thoroughly analyzed through the environmental evaluation process and discussed within the community using informal public involvement methods, a hearing is held to present and gather testimony. The hearing is timed to fall within the comment period for the Draft EIS.

For an environmental hearing, the hearing notice must be published at least 15 days prior to the hearing. The timing of additional publications is optional (see [Exhibit 210-4](#)).

Responses to comments on the Draft EIS must be addressed in the Final EIS.

### **(1) Environmental Hearing Summary**

The environmental hearing summary includes the items outlined in [210.05\(10\)](#).

### **(2) Adoption of Environmental Hearing**

[Chapter 225](#) and the *Environmental Procedures Manual* provide guidance on NEPA and SEPA procedures, documentation requirements, and approvals.

## **210.07 Corridor Hearing**

A corridor hearing is a public hearing that:

- Is held before WSDOT is committed to a preferred alternative establishing the final route corridor.
- Is held to ensure opportunity is afforded for effective participation by interested persons in the process of determining the need for and location of a state highway.
- Provides the public an opportunity to present views on the social, economic, and environmental effects of the proposed alternative highway corridors.

A corridor hearing is required if any of the following project actions would occur:

- Proposed route on new location.
- Substantial social, economic, or environmental impacts.
- Significant change in layout or function of connecting roads or streets.

When a corridor hearing is held, the region must provide enough design detail on the proposed alignment(s) within the corridor(s) that an informed presentation can be made at the hearing. Justification to abandon an existing corridor must also be presented.

For general procedures and notification requirements, see [210.05](#) and [Exhibit 210-4](#).

### **(1) Corridor Hearing Summary**

After the hearing, the region:

- Reviews the hearing transcript.
- Responds to all questions or proposals submitted at or subsequent to the hearing.
- Compiles a corridor hearing summary.
- Transmits three copies (four copies for Interstate projects) to the HQ Access and Hearings Section.

When appropriate, the hearing summary may be included in the FEIS. If not included, submit the complete corridor hearing summary to the HQ Access and Hearings Section within approximately two months following the hearing.

The corridor hearing summary includes the items outlined in [210.05\(10\)](#).

### **(2) Adoption of Corridor Hearing Summary**

The HQ Access and Hearings Section prepares a package that contains the corridor hearing summary and a formal description of the project and forwards it to the Assistant Secretary, Engineering & Regional Operations, for adoption. The HQ Hearing Coordinator notifies the region when adoption has occurred and returns an approved copy to the region.

## 210.08 Design Hearing

A design hearing is a public hearing that:

- Is held after a route corridor is established and approved, but before final design of a highway is engineered.
- Is held to ensure an opportunity is afforded for the public to present its views on each proposed design alternative, including the social, economic, and environmental effects of those designs.

A design hearing is required if any of the following project actions will occur:

- Substantial social, economic, or environmental impacts.
- Significant change in layout or function of connecting roads or streets.
- Acquisition of a significant amount of right of way results in relocation of individuals, groups, or institutions.

For general procedures and notification requirements, see [210.05](#) and [Exhibit 210-4](#).

### (1) Design Hearing Summary

The design hearing summary includes the elements outlined in [210.05\(10\)](#).

Submit the complete hearing summary to the HQ Access and Hearings Section within approximately two months following the hearing.

If new studies or additional data are required subsequent to the hearing, the region compiles the information in coordination with the HQ Design Office.

### (2) Adoption of Design Hearing Summary

After the hearing, the region reviews the hearing transcript, responds to all questions or proposals submitted at or subsequent to the hearing, compiles a hearing summary, and transmits three copies (four copies for Interstate projects) to the HQ Access and Hearings Section. When appropriate, the design hearing summary may be included in the final environmental document. The HQ Access and Hearings Section prepares a formal document that identifies and describes the project and submits it to the Director & State Design Engineer, Development Division, for approval. One approved copy is returned to the region. The HQ Hearing Coordinator notifies the region that adoption has occurred.

On Interstate projects, the Director & State Design Engineer, Development Division, (or designee) submits the approved design hearing summary to the FHWA for federal approval. If possible, this submittal is timed to coincide with the submittal of the Design Decision Summary to the FHWA.

### (3) Public Notification of Action Taken

The region prepares a formal response to individuals who had unresolved questions at the hearing. The region keeps the public advised regarding the result(s) of the hearing process, such as project adoption or revision to the plan. A project newsletter sent to those on the interest list is an effective method of notification. Project news items can be sent via e-mail or by more traditional methods.

- 225.01 General
- 225.02 References
- 225.03 Determining the Environmental Documentation
- 225.04 Identifying the Project Classification
- 225.05 Environmental Commitment File
- 225.06 Environmental Permits and Approvals
- 225.07 Documentation

### 225.01 General

The term “environmental documentation” refers to the documents produced for a project to satisfy the requirements contained in the National Environmental Policy Act (NEPA) and the State Environmental Policy Act (SEPA). The *Environmental Procedures Manual* and supporting web pages provide detailed instructions on how to determine what level of documentation is required and how to prepare the documents. This chapter provides a summary of the relevant provisions in the *Environmental Procedures Manual*.

The purpose of the environmental document is to provide decision makers, agencies, and the public with information on a project’s environmental impacts, alternatives to the proposed action, and mitigation measures to reduce unavoidable impacts. Final environmental documents identify and evaluate the project to be constructed. Because projects vary in their level of environmental impacts, the rules on environmental documentation allow for different levels of documentation. As a project’s impacts increase, so does the level of documentation.

The region Environmental Office and the NEPA/SEPA Compliance Section of the Headquarters Environmental Services Office routinely provide environmental documentation assistance to designers and project engineers.

### 225.02 References

#### 225.02(1) Federal/State Laws and Codes

[42 United States Code \(USC\) Chapter 55](#), National Environmental Policy Act of 1969 (NEPA)

[23 Code of Federal Regulations \(CFR\) Part 771](#), Environmental Impact and Related Procedures

[23 CFR Part 774](#); [49 USC Section 303](#), Policy on Lands, Parks, Recreation Areas, Wildlife and Waterfowl Refuges, and Historic Sites

[36 CFR Part 800](#), Protection of Historic and Cultural Properties

[40 CFR Parts 1500-1508](#), Council for Environmental Quality Regulations for Implementing NEPA

[Chapter 43.21C Revised Code of Washington \(RCW\)](#), State Environmental Policy Act (SEPA)

[Chapter 197-11 Washington Administrative Code \(WAC\)](#), SEPA Rules

[Chapter 468-12 WAC](#), WSDOT SEPA Rules

## 225.02(2) WSDOT Environmental Resources

WSDOT region environmental staff

Environmental Permitting webpage:

[www.wsdot.wa.gov/environment/permitting/default.htm](http://www.wsdot.wa.gov/environment/permitting/default.htm)

*Environmental Procedures Manual*, M 31-11, WSDOT

[www.wsdot.wa.gov/publications/manuals/m31-11.htm](http://www.wsdot.wa.gov/publications/manuals/m31-11.htm)

## 225.03 Determining the Environmental Documentation

The Environmental Review Summary (ERS) provides the first indication of what form the environmental documentation will take. The ERS is developed as part of the Project Summary, which is prepared during the scoping phase of all projects in the construction program. The Project Summary (see [Chapter 300](#) for additional information) includes three components:

- Project Definition
- Design Decision
- Environmental Review Summary

The ERS is part of the Project Summary database. The ERS describes the potential environmental impacts, proposed mitigation, and necessary permits for a project. It establishes the initial environmental classification and identifies the key environmental elements addressed in the NEPA/SEPA process. The ERS database includes fully integrated “Help” screens. Contact your region Environmental Office or Program Management Office to get set up to work in the database.

The typical process for classifying projects and determining the level of environmental documentation is as follows:

- Once the project has been sufficiently developed to assess any environmental impacts, the region completes the ERS based on the best information available at the scoping phase of development.
- The region Environmental Manager then concurs with the classification by approving the ERS, which enables the completed form to be included in the Project Summary package.
- For NEPA, if a project has been determined to be a Categorical Exclusion (CE), the Environmental Classification Summary/SEPA Checklist (ECS/SEPA Checklist) is completed. The NEPA environmental review process is considered complete when the region Environmental Manager approves the ECS package (guidance is provided in the online Help in the ECS/SEPA Checklist database). If it is determined that a Documented Categorical Exclusion (DCE), Environmental Assessment (EA), or Environmental Impact Statement (EIS) is required, the region evaluates the project schedule and arranges for preparation of the appropriate document.
- For SEPA, the signing and submittal of the ECS/SEPA Checklist completes the environmental classification process. On projects that are categorized as exempt from SEPA, the environmental process is complete unless the project requires consultation under the Endangered Species Act. On projects that do not meet the criteria for a SEPA Categorical Exemption (WACs [197-11-800](#) and [468-12](#)) and require a SEPA checklist ([WAC 197-11-960](#)) or an EIS, those documents are prepared as necessary prior to Project Development Approval.

At this early stage, the ERS allows environmental staff to consider potential impacts and mitigations and required permits. For many projects, the WSDOT Geographic Information System (GIS) Workbench coupled with a site visit provides sufficient information to fill out the ERS (see the GIS Workbench online Help).

For most WSDOT projects, the Federal Highway Administration (FHWA) is the lead agency for NEPA. Other federal lead agencies on WSDOT projects are the U.S. Army Corps of Engineers, Federal Aviation Administration, Federal Railroad Administration, and Federal Transit Administration.

## 225.04 Identifying the Project Classification

Based on the environmental considerations identified during preparation of the ERS, WSDOT projects are classified for NEPA/SEPA purposes to determine the type of environmental documentation required. Projects with a federal nexus (using federal funds, involving federal lands, or requiring federal approvals or permits) are subject to NEPA and SEPA. Projects that are state funded only, with no federal nexus, follow SEPA guidelines. Since many WSDOT projects are prepared with the intent of obtaining federal funding, NEPA guidelines are usually followed. (See Chapter 300 of the *Environmental Procedures Manual* for more information.)

## 225.05 Environmental Commitment File

As an initial part of project development, the region establishes a project commitment file. Establishment of this file generally coincides with preparation of the environmental documentation. The file consists of proposed mitigation measures; commitments made to regulatory agencies, tribes, and other stakeholders; and other documented commitments made on the project. Further commitment types (right of way, maintenance, and so on) may be added at the region's discretion.

The region Environmental Office is responsible for creating and maintaining the commitment file as a project progresses through its development process. Whenever commitments are made, they are incorporated into project documents and added to the environmental commitment file once they are finalized. Commitments are typically included within, but not limited to, the following documents or approvals and any of their supplements or amendments:

- Memoranda, Agreements, Letters, Electronic Communications
- No-Effect Letters
- Biological Assessments
- Biological Opinions
- Concurrence Letters
- SEPA Checklists
- NEPA Categorical Exclusions
- NEPA Environmental Assessments
- NEPA/SEPA Environmental Impact Statements
- Finding of No Significant Impact (FONSI)
- Record of Decision (ROD)
- Section 106 Concurrence Letter from Tribes and Department of Archaeology & Historic Preservation
- Mitigation Plans
- Environmental Permits and Applications, and Associated Drawings and Plans

Additional information (see [Procedure 490-a](#)) for establishing a commitment file is available online at WSDOT's [Tracking Commitments](#) webpage. WSDOT has a Commitment Tracking System to organize and track commitments from the commitment file. Refer to the [Environmental Procedures Manual](#) (Chapter 490) for policies associated with tracking commitments.

## 225.06 Environmental Permits and Approvals

WSDOT projects are subject to a variety of federal, state, and local environmental permits and approvals. Understanding and anticipating what permits and approvals may be required for a particular project type will assist the designer in project delivery. The [Environmental Permitting](#) website provides guidance on the applicability of permits and approvals. Because the facts of each project vary and the environmental regulations are complex, reliance on either the *Design Manual* or the [Environmental Procedures Manual](#) is insufficient. Consult region environmental staff.

The Environmental Review Summary, which is prepared as part of the Project Summary, identifies some of the most common environmental permits that might be required based on the information known at that stage. As the project design develops, additional permits and approvals can be identified. Conducting project site visits for engineering and environmental features may reduce project delays caused by late discoveries. Coordinate with and communicate any project changes to region environmental staff.

The permit process begins well in advance of the actual permit application. For some permits, WSDOT has already negotiated permit conditions through the use of programmatic and general permits. These permits typically apply to repetitive, relatively simple projects, and the permit conditions apply regardless of the actual facts of the project type. For complex projects, the negotiations with permit agencies often begin during the environmental documentation phase for compliance with the National Environmental Policy Act (NEPA) and the State Environmental Policy Act (SEPA). The mitigation measures developed for the NEPA/SEPA documents are captured as permit conditions on the subsequent permits.

Environmental permits require information prepared during the design phase to demonstrate compliance with environmental rules, regulations, and policies. To avoid delays in project delivery, it is necessary for the designer to understand and anticipate this exchange of information. The timing of this exchange often affects design schedules, while the permit requirements can affect the design itself. In complex cases, the negotiations over permit conditions can result in iterative designs as issues are raised and resolved.

## 225.07 Documentation

Refer to [Chapter 300](#) for design documentation requirements.



300.01	General
300.02	References
300.03	Definitions
300.04	Design Documentation
300.05	Project Development
300.06	FHWA Approval
300.07	Design Approval
300.08	Project Development Approval
300.09	Process Review

### 300.01 General

The Project File (PF) contains the documentation for planning, scoping, programming, design, approvals, contract assembly, utility relocation, needed right of way, advertisement, award, construction, and maintenance review comments for a project. A Project File is completed for all projects and is retained by the region office responsible for the project. Responsibility for the project may pass from one office to another during the life of a project, and the Project File follows the project as it moves from office to office. Refer to the Project File checklist for documents to be preserved in the project file:

[Project File Checklist](#)

The Design Documentation Package (DDP) is a part of the Project File and is completed for all projects. It documents and explains design decisions and the design process that was followed. The DDP is retained in a permanent retrievable file for a period of 75 years, in accordance with the Washington State Department of Transportation (WSDOT) records retention policy. Refer to the DDP checklist for documents to be preserved in the DDP:

[Design Documentation Package Checklist](#)

With the exception of the DDP, the Project File may be purged when retention of the construction records is no longer necessary.

For operational changes and local agency and developer projects, design documentation is also needed. It is retained by the region office responsible for the project, in accordance with the WSDOT records retention policy. All participants in the design process are to provide the appropriate documentation for their decisions.

For emergency projects, also refer to the *Emergency Relief Procedures Manual*. It provides the legal and procedural guidelines for WSDOT employees to prepare all necessary documentation to respond to, and recover from, emergencies and disasters that affect the operations of the department.

### 300.02 References

#### 300.02(1) Federal/State Laws and Codes

[23 Code of Federal Regulations \(CFR\) 635.111](#), Tied bids

[23 CFR 635.411](#), Material or product selection

Revised Code of Washington (RCW) 47.28.030, Contracts – State forces – Monetary limits – Small businesses, minority, and women contractors – Rules

RCW 47.28.035, Cost of project, defined

“Washington Federal-Aid Stewardship Agreement,” as implemented in the design matrices (see Chapter 1100)

### 300.02(2) Design Guidance

WSDOT Directional Documents Index, including the one listed below:

☞ <http://wwwi.wsdot.wa.gov/publications/policies>

- Executive Order E 1010, “Certification of Documents by Licensed Professionals,” WSDOT

WSDOT technical manuals, including those listed below:

☞ [www.wsdot.wa.gov/publications/manuals/index.htm](http://www.wsdot.wa.gov/publications/manuals/index.htm)

- *Advertisement and Award Manual*, M 27-02, WSDOT
- *Emergency Relief Procedures Manual*, M 3014, WSDOT
- *Environmental Procedures Manual*, M 31-11, WSDOT
- *Hydraulics Manual*, M 23-03, WSDOT
- *Plans Preparation Manual*, M 22-31, WSDOT
- *Project Control and Reporting Manual*, M 3026, WSDOT
- *Roadside Classification Plan*, M 25-31, WSDOT

Limited Access and Managed Access Master Plan, WSDOT

☞ [www.wsdot.wa.gov/design/accessandhearings/tracking.htm](http://www.wsdot.wa.gov/design/accessandhearings/tracking.htm)

Washington State Highway System Plan, WSDOT

☞ [www.wsdot.wa.gov/planning/](http://www.wsdot.wa.gov/planning/)

### 300.02(3) Supporting Information

*A Policy on Geometric Design of Highways and Streets* (Green Book), AASHTO, 2011

*Mitigation Strategies for Design Exceptions*, FHWA, July 2007. This publication provides detailed information on design exceptions and mitigating the potential adverse impacts to highway safety and traffic operations.

## 300.03 Definitions

Refer to the *Design Manual Glossary* for definitions of many of the terms used in this chapter.

## 300.04 Design Documentation

### 300.04(1) Purpose

Design documentation records the evaluations and decisions by the various disciplines that result in design recommendations. Design assumptions and decisions made prior to and during the scoping phase are included. Changes that occur throughout project development are documented. Required justifications and approvals are also included.

The “Design Documentation Package Checklist” has been developed as a tool to assist in generating the contents of the DDP and the PF: ☞ [www.wsdot.wa.gov/design/support.htm](http://www.wsdot.wa.gov/design/support.htm)

### 300.04(2) Design Documents

The DDP portion of the PF preserves the decision documents generated during the design process. In each package, a summary (list) of the documents included is recommended.

Documentation is not required for components not related to the project as dictated by the design matrices (see Chapters [1100](#) and [1110](#)).

A Design Variance Inventory (DVI) is needed for all projects that have design variances. The DVI lists all EUs not upgraded to the applicable design level, DEs, and deviations as indicated by the design matrices. Record variances that result from a project or corridor analysis in the DVI. Use the Design Variance Inventory System (DVIS) database to record and manage:

- Individual design variances identified during project development.
- Variances resulting from a project or corridor analysis.

The DVIS database can be accessed from this website: <http://wwwi.wsdot.wa.gov/design/>

The Environmental Review Summary (ERS) and the Project Definition (PD) are required for most projects. Exceptions will be identified by the HQ Capital Program Development and Management Office.

The Design Decisions (DD) form is not required for the following project types unless they involve reconstructing the lanes, shoulders, or fill slopes. Since these and some other project types are not included in the design matrices, evaluate them with respect to modified design level (M) for non-NHS routes and full design level (F) for NHS routes. Include in the evaluation only those design elements specifically impacted by the project. Although the following list illustrates some of the project types that do not require a DD, the list is not intended to be a complete accounting of all such projects. A project-specific matrix can be generated for a project. Consult with the appropriate Assistant State Design Engineer (ASDE) for projects not included on the list.

- Bridge painting
- Crushing and stockpiling
- Pit site reclamation
- Lane marker replacement
- Guidepost replacement
- Signal rephasing
- Signal upgrade
- Seismic retrofit
- Bridge joint repair
- Navigation light replacement
- Signing upgrade
- Illumination upgrade
- Intelligent Transportation System (ITS) upgrade
- Rumble strips
- Electrical upgrades
- Major drainage
- Bridge scour
- Fish passage
- Other projects approved by the HQ Design Office

### 300.04(3) Certification of Documents by Licensed Professionals

All original technical documents must bear the certification of the responsible licensee (see [Executive Order E 1010](#)).

### 300.04(4) Design Exception (DE), Evaluate Upgrade (EU), and Deviation Documentation

In special cases, projects may need to address design elements, which are shown as blank cells in a design matrix (see [Exhibit 300-1](#)). These special cases must be coordinated with the appropriate Assistant State Design Engineer (ASDE) and the HQ Capital Program Development and Management Office. When this is necessary, document the reasons for inclusion of that work in your project.

When the design matrices specify a DE for a design element, the DE documentation specifies the matrix and row, the design element, and the limits of the exception. Some DEs require justification. Include this in the DVIS. When a DVI is required for the project, the DE locations are recorded in the inventory.

Matrix Cell Contents	Design Element Meets Specified Design Level	Document to File [1]	Record in DVIS [2]
Blank cell in design matrix		No [3]	No
<b>Cell Entry</b>			
Full (F), Modified (M), or Basic (B) (with no DE or EU qualifiers)	Yes	No	No
	No [4]	Yes [5]	Yes
Design Exception (DE)	Yes [3]	DDP	No
	No	DDP	Yes
Evaluate Upgrade (EU)	Yes	DDP	No
	No [5]	DDP	Yes
DDP = Design Documentation Package <b>Notes:</b> [1] See <a href="#">300.04(3)</a> . [2] See <a href="#">300.04(2)</a> . [3] Document to the DDP if the element is included in the project as identified in the Project Summary or Project Change Request Form. [4] Nonconformance with specified design level (see <a href="#">Chapter 1100</a> ) requires an approved deviation. [5] Requires supporting justification (see <a href="#">300.04(4)</a> and <a href="#">300.04(5)</a> ).			

### Design Matrix Documentation Requirements *Exhibit 300-1*

The EU process determines whether an item of work will or will not be done, through analysis of factors such as benefit/cost, route continuity, collision reduction potential, environmental impact, and economic development. Document all EU decisions to the DDP using the list in [Exhibit 300-5](#) as a guide for the content. The cost of the improvement must always be evaluated when making EU decisions.

Deviation requests are stand-alone documents that require enough information and project description for an approving authority to make an informed decision of approval or denial. Documentation of a deviation contains justification and is approved at the appropriate administrative level, as shown in [Exhibit 300-2](#).

### 300.04(5) Deviation Approval

Deviation approval is at the appropriate administrative level, as shown in [Exhibit 300-2](#).

If the element meets current AASHTO guidance adopted by the Federal Highway Administration (FHWA), such as *A Policy on Geometric Design of Highways and Streets*, but not *Design Manual* criteria, it is a deviation from the *Design Manual* that does not require approval by FHWA or the HQ Design Office. It does require region approval.

The following documentation is required:

- Identify the design element.
- Explain why the design level specified in the design matrices was not used.
- Explain which AASHTO guidance was used, including the title of the AASHTO guidance, the publication date, and the chapter and page number of the guidance.

When applying for deviation approval from *Design Manual* criteria, it is necessary to provide two explanations. The first identifies the design element and explains why the design level specified in the design matrices was not or cannot be used. The second provides the justification for the proposed design. Justification for a deviation is to be supported by at least two explanations, which may include the following:

- Collision history and analysis
- Benefit/cost analysis
- Engineering judgment\*
- Environmental issues
- Route continuity

\*Engineering judgment may include a reference to another publication, with an explanation of why that reference is applicable to the situation encountered on the project.

To prepare a deviation request, use the list in [Exhibit 300-6](#) as a general guide for the sequence of the content. The list is not all-inclusive of potential content and it might include suggested topics that do not apply to a particular project.

Reference an approved route development plan or other approved study, if one exists, as supporting justification for design deviations dealing with route continuity issues (see [Chapter 1100](#)).

When several design variances are proposed in a corridor, and they have similar contributing factors or are intertwined in their effects on each other, they can sometimes be handled in a single project analysis (see [Chapter 1100](#)). Coordinate this approach with your ASDE.

Once a design variance is approved, it applies to that project only. When a new project is programmed at the same location, the subject design element is to be reevaluated, and either the subject design element is rebuilt to conform to the applicable design level or a new deviation is developed, approved, and preserved in the DDP for the new project. Check the DVIS for help in identifying previously granted deviations. Keep in mind that the *Design Manual* is continually evolving. What may have met guidelines once may not meet current guidelines.

A change in a design level resulting from an approved corridor planning study, or a corridor or project analysis as allowed in design matrix notes, is documented similar to a deviation. Use [Exhibit 300-6](#) as a guide to the outline and contents of your project analysis. Design elements that do not comply with the design level specified in an approved corridor or project analysis are documented as deviations.

For design deviation examples, see: [www.wsdot.wa.gov/design/projectdev](http://www.wsdot.wa.gov/design/projectdev)

### 300.05 Project Development

In general, the region initiates the development of a specific project by preparing the Project Summary (see [300.05\(2\)](#)). Projects may also be initiated by other WSDOT groups such as the HQ Bridge and Structures Office or the HQ Traffic Office. The project coordination with other disciplines (such as Real Estate Services, Roadside and Site Development, Utilities, and Environmental) is started in the project scoping phase and continues throughout the project's development. The region coordinates with state and federal resource agencies and local governments to provide and obtain information to assist in developing the project.

The project is developed in accordance with all applicable Directives, Instructional Letters, Supplements, and manuals; the Limited Access and Managed Access Master Plan; the Washington State Highway System Plan; approved corridor planning studies; the Washington Federal-Aid Highway Stewardship Agreement as implemented in the design matrices (see [Chapter 1100](#)); and the Project Summary.

The region develops and maintains documentation for each project. The Project File/ Design Documentation Package includes documentation of project work, including planning; scoping; public involvement; environmental action; design decisions; right of way acquisition; Plans, Specifications, and Estimates (PS&E) development; project advertisement; and construction. Refer to the *Plans Preparation Manual* for PS&E documentation. [Exhibit 300-7](#) is an example checklist of recommended items to be turned over to the construction office at the time of project transition. An expanded version is available here: [www.wsdot.wa.gov/design/projectdev/](http://www.wsdot.wa.gov/design/projectdev/)

All projects involving a federal action require National Environmental Policy Act (NEPA) documentation. WSDOT uses the Environmental Classification Summary (ECS) form for FHWA concurrence/approval on the environmental documentation for Class II projects (CE/DCE/PCE). The environmental approval levels are shown in [Exhibit 300-3](#).

Upon receipt of the ECS approval for projects requiring an EA or EIS under NEPA, the region proceeds with environmental documentation, including public involvement, appropriate for the magnitude and type of the project (see [Chapter 210](#)).

Design Approval and approval of right of way plans are required prior to acquiring property. Recent changes to federal law ([23 USC 108](#)) allow for acquisition of right of way using federal funds prior to completion of NEPA. However, WSDOT H&LP, ESO, and Real Estate Services are working with FHWA to prepare procedures for this early acquisition as this manual was going to press. (See the [April 2, 2013, memorandum on early acquisition policy](#) for more information.)

The ASDEs work with the regions on project development and conduct process reviews on projects as described in [300.09](#).

### 300.05(1) Scoping Phase

Development of the project scope is the initial phase of project development. This effort is prompted by the Washington State Highway System Plan. The project scoping phase consists of determining a project's description, schedule, and cost estimate. The intent is to make design decisions early in the project development process that focus the scope of the project, keeping in mind the guidance provided by the matrices where applicable. During the project scoping phase, the Project Summary documents are produced. For projects not covered by a matrix line from [Chapter 1100](#), a project-specific matrix can be developed and approved at this phase.

### 300.05(2) Project Summary

The Project Summary provides information on the results of the scoping phase; links the project to the Washington State Highway System Plan and the Capital Improvement and Preservation Program (CIPP); and documents the design decisions, the environmental classification, and agency coordination. The Project Summary is developed and approved before the project is funded for design and construction, and it consists of ERS, DD, and PD documents. The Project Summary database contains specific online instructions for completing the documents.

#### 300.05(2)(a) Environmental Review Summary (ERS)

The ERS lists the potential required environmental permits and approvals, environmental classifications, and environmental considerations. The ERS is prepared during the scoping phase and is approved by the region. If there is a change in the PD or DD, the information in the ERS must be reviewed and revised to match the rest of the Project Summary. For actions classified under NEPA, the approved ERS becomes the ECS when the project is funded and moves to design. If the NEPA class of action is a CE, PCE, or DCE, the region may revise the ECS as appropriate (usually during final design). The ECS serves as the NEPA environmental documentation for CE/PCE/DCE projects. The region Environmental Manager approves the ECS, except in the case of DCEs, which are forwarded to FHWA for its approval. The ERS/ECS database includes fully integrated help screens that provide detailed guidance. Contact your region Environmental Office for access.

#### 300.05(2)(b) Design Decisions (DD)

The DD generally provides the design matrix used to develop the project, as well as the roadway geometrics, design variances, other roadway features, roadside restoration, and any design decisions made during the scoping of a project. The information contained in this form is compiled from various databases of departmental information, field data collection, and evaluations made in development of the PD and the ERS. Design decisions may be revised throughout the project development process based on continuing evaluations.

The appropriate ASDE concurs with the Design Decisions for all projects requiring a DD. The region design authority approves the DD when confident there will be no significant change in the PD or estimated cost. Schedule, scope, or cost changes require a Project Change Request Form to be submitted and approved by the appropriate designee, in accordance with the [Project Control and Reporting Manual](#).

### 300.05(2)(c) Project Definition (PD)

The PD identifies the various disciplines and design elements that are anticipated to be encountered in project development. It also states the purpose and need for the project, the program categories, and the recommendations for project phasing. The PD is completed early in the scoping phase to provide a basis for full development of the ERS, DD, schedule, and estimate. If circumstances necessitate a change to an approved PD, process a Project Change Request Form for approval by the appropriate designee.

### 300.06 FHWA Approval

For all National Highway System (NHS) projects, the level of FHWA oversight varies according to the type of project, the agency doing the work, and the funding source, as shown in [Exhibit 300-2](#). Oversight and funding do not affect the level of design documentation required for a project.

FHWA approval is required for any new or revised access point (including interchanges, temporary access breaks, and locked gate access points) on the Interstate System, regardless of funding (see [Chapter 550](#)).

Documents for projects requiring FHWA review, Design Approval, and Project Development Approval are submitted through the HQ Design Office.

### 300.07 Design Approval

When the Project Summary documents are complete, and the region is confident that the proposed design adequately addresses the purpose and need for the project, a Design Approval may be pursued and granted at this early stage. Early approval is an option at this point in the design phase and is likely most relevant to larger projects with longer PE phases because it provides early approved documentation that locks in design policy for three years. This is a benefit for longer PE phases in that it avoids design changes due to policy updates during that time and provides consistency when purchasing right of way or producing environmental documentation.

If early Design Approval is not beneficial for a subject project, the typical items (below) that are part of this package become required in the combined Design Approval/Project Development Approval Package. Design Approval may occur prior to NEPA approval. Generally, Design Approval will not be provided prior to an IJR being approved on an Interstate project. Approval levels for design and PS&E documents are presented in Exhibits [300-2](#) through [300-4](#).

The following items are typically provided for Design Approval:

- Stamped cover sheet (project description)
- A reader-friendly memo that describes the project
- Project Summary documents
- Corridor or project analysis
- Design Variance Inventory (for known design variances at this stage)
- Design Criteria worksheets or equivalent: [www.wsdot.wa.gov/design/support.htm](http://www.wsdot.wa.gov/design/support.htm)
- Channelization plans, intersection plans, or interchange plans (if applicable)
- Alignment plans and profiles (if project significantly modifies either the existing vertical or horizontal alignment)
- Current cost estimate with a confidence level



Design Approval is entered into the Design Documentation Package and remains valid for three years or as approved by the HQ Design Office. Evaluate policy changes or revised design criteria that are adopted by the department during this time to determine whether these changes would have a significant impact on the scope or schedule of the project. If it is determined that these changes will not be incorporated into the project, document this decision with a memo from the region Project Development Engineer that is included in the DDP. For an overview of design policy changes, consult the Detailed Chronology of *Design Manual* revisions:

🔗 [www.wsdot.wa.gov/design/policy/default.htm](http://www.wsdot.wa.gov/design/policy/default.htm)

### **300.07(1) Alternative Project Delivery Methods**

Design Approval applies to projects delivered using alternative means, including design-build projects. Design documentation begins in the project scoping phase and continues through the life of the design-build project. This documentation is thus started by WSDOT and is completed by the design-builder. Since Design Approval is related to project scoping, this milestone shall be accomplished prior to issuing a Design-Build Request for Proposal (see [Exhibit 110-1](#)). However, the design-builder shall refer to the Request for Proposal (RFP) for direction on approval milestones.

### **300.08 Project Development Approval**

When all project development documents are completed and approved, Project Development Approval is granted by the approval authority designated in [Exhibit 300-2](#). The Project Development Approval becomes part of the DDP. Refer to this chapter and the DDP checklist for design documents that may lead to Project Development Approval. Exhibits [300-2](#) through [300-4](#) provide approval levels for project design and PS&E documents.

The following items must be approved prior to Project Development Approval:

- Required environmental documentation
- Design Approval documents (and any supplements)
- Updated Design Variance Inventory (all project design variances)
- Cost estimate
- Stamped cover sheet (project description)

Project Development Approval remains valid for three years. Evaluate policy changes or revised design criteria that are adopted by the department during this time to determine whether these changes would have a significant impact on the scope or schedule of the project. If it is determined that these changes will not be incorporated into the project, document this decision with a memo from the region Project Development Engineer that is included in the DDP. For an overview of design policy changes, consult the Detailed Chronology of *Design Manual* revisions:

🔗 [www.wsdot.wa.gov/design/policy/default.htm](http://www.wsdot.wa.gov/design/policy/default.htm)

### **300.08(1) Alternative Project Delivery Methods**

For projects delivered using alternative methods, such as design-build, the design-builder shall refer to the project RFP for specification on final and intermediate deliverables and final records for the project. Project Development Approval is required prior to project completion.

It is a prudent practice to start the compilation of design documentation early in a project and to acquire Project Development Approval before the completion of the project. At the start of a project, it is critical that WSDOT project administration staff recognize the importance of all required documentation and how it will be used in the design-build project delivery process.

## 300.09 Process Review

The process review is done to provide reasonable assurance that projects are prepared in compliance with established policies and procedures and that adequate records exist to show compliance with state and federal requirements. Process reviews are conducted by WSDOT, FHWA, or a combination of both.

The design and PS&E process review is performed in each region at least once each year by the HQ Design Office. The documents used in the review process are the Design Documentation Package Checklist, the PS&E Review Checklist, and the PS&E Review Summary. These are generic forms used for all project reviews. Copies of these working documents are available for reference when assembling project documentation. The HQ Design Office maintains current copies at: [www.wsdot.wa.gov/design/support.htm](http://www.wsdot.wa.gov/design/support.htm)

Each project selected for review is examined completely and systematically beginning with the scoping phase (including planning documents) and continuing through contract plans and, when available, construction records and change orders. Projects are normally selected after contract award. For projects having major traffic design elements, the HQ Traffic Operations Office is involved in the review. The WSDOT process reviews may be held in conjunction with FHWA process reviews.

The HQ Design Office schedules the process review and coordinates it with the region and FHWA.

### 300.09(1) Process Review Agenda

A process review follows this general agenda:

1. Review team meets with region personnel to discuss the object of the review.
2. Review team reviews the design and PS&E documents, construction documents, and change orders (if available) using the checklists.
3. Review team meets with region personnel to ask questions and clarify issues of concern.
4. Review team meets with region personnel to discuss findings.
5. Review team submits a draft report to the region for comments and input.
6. If the review of a project shows a serious discrepancy, the region design authority is asked to report the steps that will be taken to correct the deficiency.
7. Process review summary forms are completed.
8. Summary forms and checklists are evaluated by the Director & State Design Engineer, Development Division.
9. Findings and recommendations of the Director & State Design Engineer, Development Division, are forwarded to the region design authority for action and/or information within 30 days of the review.

Project Design	FHWA Oversight Level	Deviation and Corridor/Project Approval [1][2]	EU Approval [2]	Design and Project Development Approvals
<b>Interstate</b>				
New/Reconstruction [3] Federal funds	[4]	FHWA	Region	FHWA [10]
No federal funds	[5]			
Intelligent Transportation Systems (ITS) Improvement project over \$1 million	[6]	HQ Design	Region	HQ Design
Preservation project	[6]	HQ Design	Region	Region
All Other [7] Federal funds	[6]	HQ Design	Region	Region
State funds	[6]			
Local agency funds	[5]			
<b>National Highway System (NHS)</b>				
Managed access highway outside incorporated cities and towns or inside unincorporated cities and towns, or limited access highway	[6]	HQ Design [12]	Region	Region
Managed access highway within incorporated cities and towns [8] Inside curb or EPS [9][13]	[6]	HQ Design	Region	Region
Outside curb or EPS	[6]	HQ H&LP	N/A	City/Town
<b>Non-National Highway System (Non-NHS)</b>				
Improvement project on managed access highway outside incorporated cities and towns or within unincorporated cities and towns, or on limited access highway (Matrix lines 5-9 through 5-24)	N/A	HQ Design	Region	Region
Improvement project on managed access highway within incorporated cities and towns [8] Inside curb or EPS [9][13]	N/A	HQ Design	Region	Region
Outside curb or EPS (Matrix lines 5-9 through 5-24)	N/A	HQ H&LP	N/A	City/Town
Preservation project on managed access highway outside incorporated cities and towns or within unincorporated cities and towns, or on limited access highway [11] (Matrix lines 5-2 through 5-8)	N/A	Region	Region	Region
Preservation project on managed access highway within incorporated cities and towns [8][11] Inside curb or EPS [9][13]	N/A	Region	Region	Region
Outside curb or EPS (Matrix lines 5-2 through 5-8)	N/A	HQ H&LP	N/A	City/Town

For table notes, see the following page.

### Design Approval Level

Exhibit 300-2

FHWA = Federal Highway Administration  
HQ = WSDOT Headquarters  
H&LP = WSDOT Highways & Local Programs Office  
EPS = Edge of paved shoulder where curbs do not exist

**Notes:**

- [1] These approval levels also apply to deviation processing for local agency work on a state highway.
- [2] See [300.04\(4\)](#).
- [3] For definition, see [Chapter 1100](#).
- [4] Requires FHWA review and approval (full oversight) of design and PS&E submitted by the HQ Design Office.
- [5] To determine the appropriate oversight level, FHWA reviews the Project Summary (or other programming document) submitted by the HQ Design Office or by WSDOT Highways & Local Programs through the HQ Design Office.
- [6] FHWA oversight is accomplished by process review (see [300.09](#)).
- [7] Reduction of through lane or shoulder widths (regardless of project type) requires FHWA review and approval of the proposal, except shoulder reductions as allowed by [1140.09](#) for seismic retrofit projects.
- [8] Applies to the area within the incorporated limits of cities and towns.
- [9] Includes raised medians.
- [10] FHWA will provide Design Approval prior to NEPA Approval, but will not provide Project Development Approval until NEPA is complete.
- [11] For Bridge Replacement projects in the Preservation program, follow the approval level specified for Improvement projects.
- [12] For guidance on access deviations, see [Chapter 530](#).
- [13] Curb ramps are still included (see [Chapter 1510](#)).

**Design Approval Level**  
*Exhibit 300-2 (continued)*

Item	Approval Authority		
	Region	HQ	FHWA
<b>Program Development</b>			
Work Order Authorization		X	X [1]
<b>Public Hearings</b>			
Corridor Hearing Summary		X [2]	
Design Summary		X [3]	
Access Hearing Plan		X [4]	
Access Findings and Order		X [5]	
<b>Environmental Document</b>			
Environmental Classification Summary (ECS) NEPA			X
Class I NEPA (EIS)		[7]	X
SEPA (EIS)		X	
<u>Class II NEPA – Categorical Exclusion (CE)</u>	X		
Class II NEPA – <u>Programmatic</u> Categorical Exclusion (PCE)	X		
Class II NEPA – Documented Categorical Exclusion (DCE)	[6]		X
SEPA – Categorical Exemption (CE)	X		
Class III NEPA – Environmental Assessment (EA)		[7]	X
SEPA Environmental Checklist & Determination of Non-Significance (DNS)	X		
<b>Design</b>			
<u>Intersection Control Type</u>	X [22]	[7]	
Experimental Features		X	X [9]
Environmental Review Summary	X		
Final Design Decisions	X	X [3]	
Final Project Definition		X [10]	
Interstate Interchange Justification Report		[7]	X
Any Break in Interstate Limited Access		[7]	X
Non-Interstate Interchange Justification Report		X	
Break in Partial or Modified Limited Access		X	
Intersection or Channelization Plans	X [11]		
Right of Way Plans	[12]	X	
Monumentation Map	X		
Materials Source Report		X [13]	
Pavement Determination Report		X [13]	
Roundabout Geometric Design (see <a href="#">Chapter 1320</a> for guidance)	X		
Resurfacing Report		X [13]	

Table is continued on the following page, which also contains the notes.

**Approvals**  
**Exhibit 300-3**

Item	Approval Authority		
	Region	HQ	FHWA
<b>Design (continued)</b>			
Signal Permits	X [14]		
Geotechnical Report		X [13]	
Tied Bids	X [15]		X [9][15]
Bridge Design Plans (Bridge Layout)	X	X	
Hydraulic Report	X [16]	X [16]	
Preliminary Signalization Plans		X [6][20]	
Signalization Plans	X [22]		
Illumination Plans	X [22]		
Intelligent Transportation System (ITS) Plans	X [22]		
ITS Project Systems Engineering Review Form (Exhibit 1050-2)	X [22]		X [1]
Rest Area Plans		X	
Roadside Restoration Plans	X [18]	X [19]	
Structures Requiring TS&Ls		X	X
Planting Plans	X [18]	X [19]	
Grading Plans	X		
Continuous Illumination – Main Line		X [20]	
Tunnel Illumination		X [20]	
High Mast Illumination		X [20]	
Project Change Request Form	X [21]	X [21]	
Work Zone Transportation Management Plan/Traffic Control Plan	X [22]		
Public Art Plan – Interstate (see Chapter 950)	X [18][23]	X [19][23]	X[9][19][23]
Public Art Plan – Non-Interstate (see Chapter 950)	X [18][23]	X [19][23]	
ADA Maximum Extent Feasible Document (see Chapter 1510)	X	X	

X Normal procedure

**Notes:**

- |  |   |
|--|---|
| [1] Federal-aid projects only.   | [13] Submit to HQ Materials Laboratory for review and approval.   |
| [2] Approved by Assistant Secretary, Engineering & Regional Operations.                                | [14] Approved by Regional Administrator or designee.  |
| [3] Approved by Director & State Design Engineer, Development Division.                                | [15] See <a href="#">23 CFR 635.111</a> .   |
| [4] Approved by Right of Way Plans Manager.  | [16] See the <a href="#">Hydraulics Manual</a> for approvals levels.  |
| [5] Refer to <a href="#">Chapter 210</a> for approval requirements.                                    | [18] Applies only to regions with a Landscape Architect.  |
| [6] Final review & concurrence required at the region level prior to submittal to approving authority. | [19] Applies only to regions without a Landscape Architect.   |
| [7] Final review & concurrence required at HQ prior to submittal to approving authority.               | [20] Approved by State Traffic Engineer.  |
| [9] Applies to new/reconstruction projects on Interstate routes.                                       | [21] Consult <a href="#">Capital Program Development and Management</a> for clarification on approval authority.  |
| [10] Approved by HQ <a href="#">Capital Program Development and Management</a> .                       | [22] Region Traffic Engineer or designee.   |
| [11] Include channelization details.   | [23] The State Bridge and Structures Architect reviews and approves the public art plan (see <a href="#">Chapter 950</a> for further details on approvals). |
| [12] Certified by the responsible professional licensee.   |   |

**Approvals**  
*Exhibit 300-3 (continued)*

Item	New/Reconstruction (Interstate only)	NHS and Non-NHS
DBE/training goals * **	(a)	(a)
Right of way certification for federal-aid projects	FHWA (b)	FHWA (b)
Right of way certification for state-funded projects	Region (b)	Region (b)
Railroad agreements	(c)	(c)
Work performed for public or private entities *	[1][2]	Region [1][2]
State force work *	FHWA [3][4](d)	Region [3](d)
Use of state-furnished materials *	FHWA [4]	<u>Region [3](d)</u>
Work order authorization	[5](d)	[5](d)
Ultimate reclamation plan approval through DNR	Region	Region
Proprietary item use *	[6]	[6]
Mandatory material sources and/or waste sites *	FHWA [4]	Region [4]
Nonstandard bid item use *	Region	Region
Incentive provisions	FHWA	(e)
Nonstandard time for completion liquidated damages *	FHWA (e)	(e)
Interim liquidated damages *	(f)	(f)

**Notes:**

- [1] This work requires a written agreement.
- [2] Region approval subject to \$250,000 limitation.
- [3] Use of state forces is subject to \$60,000 limitation and \$100,000 in an emergency situation, as stipulated in RCWs [47.28.030](#) and [47.28.035](#).
- [4] Applies only to federal-aid projects; however, document for all projects.
- [5] Prior FHWA funding approval required for federal-aid projects.
- [6] FHWA approves only for federal-aid projects and only when other equally suitable alternatives exist. In all other cases, the HQ Design Office is required to certify that the proprietary product is either:  
(a) necessary for synchronization with existing facilities, or (b) a unique product for which there is no equally suitable alternative.

**Region or Headquarters Approval Authority:**

- (a) Office of Equal Opportunity
- (b) HQ Real Estate Services Office
- (c) HQ Design Office
- (d) Capital Program Development and Management
- (e) HQ Construction Office
- (f) Statewide Travel and Collision Data Office

**References:**

\* [Plans Preparation Manual](#)

\*\* [Advertisement and Award Manual](#)

**PS&E Process Approvals**  
*Exhibit 300-4*

1. **Design Element Upgraded to the Level Indicated in the Matrix**
  - (a) Design element information
    - Design element
    - Location
    - Matrix number and row
  - (b) Cost estimate [1]
  - (c) B/C ratio [2]
  - (d) Summary of the justification for the upgrade [3]
  
2. **Design Element Not Upgraded to the Level Indicated in the Matrix**
  - (a) Design element information
    - Design element
    - Location
    - Matrix number and row
  - (b) Existing conditions
    - Description
    - Collision summary
    - Advantages and disadvantages of leaving the existing condition unchanged
  - (c) Design using the *Design Manual* criteria
    - Description
    - Cost estimate [1]
    - B/C ratio [2]
    - Advantages and disadvantages of upgrading to the level indicated in the matrix
  - (d) Selected design, if different from existing but less than the level indicated in the matrix
    - Description
    - Cost estimate [1]
    - B/C ratio [2]
    - Advantages and disadvantages of the selected design
  - (e) Summary of the justification for the selected design [3]

**Notes:**

- [1] An estimate of the approximate total additional cost for the proposed design. Estimate may be based on experience and engineering judgment.
- [2] Include only when B/C is part of the justification. An approximate value based on engineering judgment may be used.
- [3] A brief (one or two sentence) explanation of why the proposed design was selected.

**Evaluate Upgrade (EU) Documentation Contents List***Exhibit 300-5*



**1. Overview**

- (a) The safety or improvement need that the project is to meet
- (b) Description of the project as a whole
- (c) Highway classification and applicable design matrix number and row
- (d) Funding sources
- (e) Evidence of deviations approved for previous projects (same location)

**2. Design Alternatives in Question**

- (a) Existing conditions and design data
  - Location in question
  - Rural, urban, or developing
  - Approved corridor study
  - Environmental issues
  - Right of way issues
  - Number of lanes and existing geometrics
  - Current and 20-year projected ADT
  - Design speed, posted speed, and operating speed
  - Percentage of trucks
  - Terrain designation
  - Managed access or limited access
- (b) Design Manual criteria to be deviated
- (c) Collision Summary and Analysis
- (d) Design using the *Design Manual* criteria
  - Description
  - Cost estimate
  - B/C ratio
  - Advantages and disadvantages
  - Reasons for considering other designs
- (e) Other alternatives (may include “No-build” alternative)
  - Description
  - Cost estimate
  - B/C ratio
  - Advantages and disadvantages
  - Reasons for rejection
- (f) Selected design requiring justification or documentation to file
  - Description
  - Cost estimate
  - B/C ratio
  - Advantages and disadvantages

**3. Concurrences, Approvals, and Professional Seals****Deviation Request and Project Analysis Contents List***Exhibit 300-6*

This checklist is recommended for use when coordinating project transition from design to construction.

### 1. Survey

- End areas (cut & fill)
- Staking data
- Horizontal/Vertical control
- Monumentation/Control information

### 2. Design Backup

- Index for all backup material
- Backup calculations for quantities
- Geotech shrink/swell assumptions
- Design decisions and constraints
- Approved deviations & project/corridor analysis
- Hydraulics/Drainage information
- Clarify work zone traffic control/workforce estimates
- Geotechnical information (report)
- Package of as-builts used (which were verified) and right of way files
- Detailed assumptions for construction CPM schedule (working days)
- Graphics and design visualization information (aerials)
- Specific work item information for inspectors (details not covered in plans)
- Traffic counts
- Management of utility relocation

### 3. Concise Electronic Information With Indices

- Detailed survey information (see Survey above)
- Archived InRoads data
- Only one set of electronic information
- "Storybook" on electronic files (what's what)
- CADD files

### 4. Agreements, Commitments, and Issues

- Agreements and commitments by WSDOT
- RES commitments
- Summary of environmental permit conditions/commitments
- Other permit conditions/commitments
- Internal contact list
- Construction permits
- Utility status/contact
- Identification of the work elements included in the Turnback Agreement (recommend highlighted plan sheets)

### 5. Construction Support

- Assign a Design Technical Advisor (Design Lead) for construction support

An expanded version of this checklist is available [at: !\[\]\(e3275251d0893157c3584e20c81dc3ba\_img.jpg\) www.wsdot.wa.gov/design/projectdev](http://www.wsdot.wa.gov/design/projectdev)

## Design to Construction Transition Project Turnover Checklist Example

*Exhibit 300-7*

- 305.01 Introduction
- 305.02 References
- 305.03 Definitions
- 305.04 Design Project Management Overview
- 305.05 Cost Estimating for Design Project Development
- 305.06 Value Engineering
- 305.07 Context Sensitive Solutions (CSS)
- 305.08 Additional Design Resources

## 305.01 Introduction

This chapter outlines the principles and methodology adopted by the Washington State Department of Transportation (WSDOT) for successful project management. WSDOT's project management process is the standard practice adopted by the department to manage projects, and it provides a method to meet WSDOT's [Management Principles](#). This chapter focuses on preconstruction activities such as cost estimating, risk management, task planning, schedule development, and budgeting, as well as managing scope, schedule, and budget.

The WSDOT Secretary's Executive Orders 1028.01, 1032.01, 1038.00, 1042.00, and 1053.00 were issued to ensure a consistent process for context sensitive solutions (CSS), design project management, and risk-management statewide. (See [Chapter 130](#) for more information about CSS.)

WSDOT's project management process includes "best management practices" and the tools, templates, examples, and guidance necessary to successfully deliver Capital Transportation projects. The process will enhance communications when designers hand off projects to construction project management.

Following are brief discussions about and links to other WSDOT project development resources. These include technical manuals, research reports, and online design-related websites.

## 305.02 References

### (1) *Federal/State Laws and Codes*

[23 United States Code \(USC\) 106](#), Project approval and oversight

### (2) *WSDOT Policies*

Directives, Executive Orders, Instructional Letters, Manuals, and Policy Statements

<http://wwwi.wsdot.wa.gov/publications/policies/default.htm>

Executive Order E 1028, Context Sensitive Solutions

<http://wwwi.wsdot.wa.gov/publications/policies/fulltext/1028.pdf>

Executive Order E 1032, Project Management

<http://wwwi.wsdot.wa.gov/publications/policies/fulltext/1032.pdf>

Executive Order E 1038, Enterprise Risk Management

☞ <http://wwwi.wsdot.wa.gov/publications/policies/fulltext/1038.pdf>

Executive Order E 1042, Project Management and Reporting System (PMRS)

☞ <http://wwwi.wsdot.wa.gov/publications/policies/fulltext/1042.pdf>

Executive Order E 1053, Project Risk Management and Risk Based Estimating

☞ [www.wsdot.wa.gov/publications/fulltext/cevp/1053policy.pdf](http://www.wsdot.wa.gov/publications/fulltext/cevp/1053policy.pdf)

Instructional Letter IL 4071.01, Risk-Based Project Estimates for Inflation Rates, Market Conditions, and Percentile Selection

☞ <http://wwwi.wsdot.wa.gov/publications/policies/fulltext/4071.pdf>

Project Delivery Memos

☞ [www.wsdot.wa.gov/design/projectdev/memos.htm](http://www.wsdot.wa.gov/design/projectdev/memos.htm)

### 305.03 Definitions

For a complete glossary of project management terms, see:

☞ [www.wsdot.wa.gov/publications/fulltext/projectmgmt/pmog/pm\\_glossary.pdf](http://www.wsdot.wa.gov/publications/fulltext/projectmgmt/pmog/pm_glossary.pdf)

For a complete glossary of cost estimating and risk assessment terms, see:

☞ <http://www.wsdot.wa.gov/nr/rdonlyres/d10b9b96-9c03-479c-8b52-17ff7bff9a0f/0/glossaryofterms.doc>

For cost estimating definitions, see:

☞ [www.wsdot.wa.gov/publications/manuals/m3034.htm](http://www.wsdot.wa.gov/publications/manuals/m3034.htm)

### 305.04 Design Project Management Overview

WSDOT's project management process provides the framework for project managers to deliver projects on time and within scope and budget. WSDOT employs a number of tools to manage projects effectively and efficiently.

#### (1) *Project Management Process*

##### (a) Overview

For an overview of project management, with links to the WSDOT project management process for delivering the WSDOT Capital Construction Program, see the following website: ☞ [www.wsdot.wa.gov/projects/projectmgmt](http://www.wsdot.wa.gov/projects/projectmgmt)

Exhibit 305-1 shows the five steps in the project management process used to deliver Capital Transportation projects. The following link takes you to a table with a more detailed description of the five steps: ☞ [http://www.wsdot.wa.gov/nr/rdonlyres/a76c71ef-c926-4a13-9615-c9f341f3baaf/0/wsdotproj\\_mgmt\\_process.pdf](http://www.wsdot.wa.gov/nr/rdonlyres/a76c71ef-c926-4a13-9615-c9f341f3baaf/0/wsdotproj_mgmt_process.pdf)

##### (b) Design Process Deliverables

The following website will take you to the Deliverable Expectation Matrix, which identifies the appropriate design process deliverable cells in the Master Deliverables List (see 305.04(2)(b)): ☞ [www.wsdot.wa.gov/publications/fulltext/design/demintro.pdf](http://www.wsdot.wa.gov/publications/fulltext/design/demintro.pdf)

- 310.01 General
- 310.02 References
- 310.03 Statewide VE Program
- 310.04 VE Procedure
- 310.05 Documentation

## 310.01 General

Value engineering (VE) analysis is a systematic process of reviewing and assessing a project by a multidisciplinary team not directly involved in the planning and development phases of a specific project. The VE process incorporates the values of design; construction; maintenance; contractor; state, local, and federal approval agencies; other stakeholders; and the public.

Value engineering analyses are conducted early in WSDOT project development to identify ideas that might reduce cost, refine scope definition, improve design functionality, improve constructability, improve coordination/schedule; and identify other value improvements, including reduced environmental impacts and congestion.

A VE analysis may be applied as a quick-response study to address a problem or as an integral part of an overall organizational effort to stimulate innovation and improve performance characteristics.

## 310.02 References

### 310.02(1) Federal Laws and Codes

[Title 23 U.S.C. Section 106\(e\)](#) – Value Engineering Analysis

[Title 23 CFR Part 627](#) – Value Engineering

MAP-21 (Moving Ahead for Progress in the 21st Century), Section 1503

Circular A-131, Office of Management and Budget (OMB)

☞ [http://www.whitehouse.gov/omb/circulars\\_a131](http://www.whitehouse.gov/omb/circulars_a131)

[FHWA Value Engineering Policy](#) (Order #1311.1A)

### 310.02(2) Design Guidance

*Value Engineering for Highways*, Study Workbook, U.S. Department of Transportation, FHWA Value Standard and Body of Knowledge, SAVE International, The Value Society:

☞ [www.value-eng.org/](http://www.value-eng.org/)

WSDOT Value Engineering website:

☞ [www.wsdot.wa.gov/design/valueengineering/](http://www.wsdot.wa.gov/design/valueengineering/)

## 310.03 Statewide VE Program

### 310.03(1) Annual VE Plan

The State VE Manager coordinates annually with the Capital Program Development and Region VE Coordinators to prepare an annual VE Plan, with specific projects scheduled quarterly. The VE Plan is the basis for determining the projected VE program needs, including team members, team leaders, consultants, and training. The Statewide VE Plan is a working document, and close coordination is necessary between Headquarters (HQ) and the regions to keep it updated and projects on schedule.

### 310.03(2) Selecting Projects for VE Analysis

#### 310.03(2)(a) Requirements

WSDOT projects for VE studies may be selected from any of the categories identified in the Highway Construction Program, including Preservation and Improvement projects, depending on the size and/or complexity of the project. In addition to the cost, other issues adding to the complexity of the project design or construction are considered in the selection process. These include projects that have critical constraints, difficult technical issues, expensive solutions, external influences, and complicated functional requirements, regardless of the estimated project cost.

WSDOT may conduct VE analyses on any project the project manager determines will benefit from the exercise. In addition, WSDOT conducts VE analyses for all projects as required by the criteria set forth in Federal Highway Administration (FHWA) Value Engineering Policy Order 1311.1A, May 25, 2010:

1. A value engineering analysis is required for:
  - Any project with an estimated cost (which includes project development, design, right of way, and construction costs) of \$25 million or more, regardless of funding;
  - Each bridge project located on or off of the federal-aid system with an estimated total cost of \$20 million or more (WSDOT policy is to conduct a VE analysis regardless of funding source); and
  - Any other projects the Secretary or FHWA determines to be appropriate.
2. In addition to the projects described above, WSDOT strongly encourages a VE analysis on other projects where there is a high potential for cost savings in comparison to the cost of the VE analysis, or the potential exists to improve the projects' performance or quality. Projects involving complex technical issues, challenging project constraints, unique requirements, and competing community and stakeholder objectives offer opportunities for improved value by conducting VE analyses.
3. Any use of Federal-Aid Highway Program (FAHP) funding on a Major Project<sup>1</sup> requires that a VE analysis be conducted. In some cases, regardless of the amount of FAHP funding, a project team may be required to perform more than one VE analysis for a Major Project.

---

<sup>1</sup> Based on the *Safe, Accountable, Flexible, Efficient Transportation Equity Act: A Legacy for Users (SAFETEA-LU)*, signed into law on August 10, 2005, a Major Project is defined as "a project with a total estimated cost of \$500 million or more that is receiving financial assistance." FHWA also has the discretion to designate a project with a total cost of less than \$500 million as a Major Project. FHWA may choose to do so in situations where the projects require a substantial portion of the State Transportation Agency's (STA's) program resources; have a high level of public or congressional interest; are unusually complex; have extraordinary implications for the national transportation system; or are likely to exceed \$500 million in total cost.

4. After completing the required VE analysis, if the project is subsequently split into smaller projects in final design or is programmed to be completed by the advertisement of multiple construction contracts, an additional VE analysis is not required. However, splitting a project into smaller projects or multiple construction contracts is not an accepted method to avoid the requirements to conduct a VE analysis.
5. WSDOT may require a VE analysis to be conducted if a region or public authority encounters instances when the design of a project has been completed but the project does not immediately proceed to construction.
  - a. If a project meeting the above criteria encounters a three-year or longer delay prior to advertisement for construction, and a substantial change to the project's scope or design is identified, WSDOT may require a new VE analysis or an update to the previous VE analysis; or
  - b. If a project's estimated cost was below the criteria identified above but the project advances to construction advertisement, and a substantial change occurs to the project's scope or design, causing an increase in the project cost so that it meets the criteria identified above and results in a **required re-evaluation of the environmental document**, WSDOT requires that a new VE analysis be conducted.
6. When the design of a project has been completed but the project does not immediately proceed to construction, the requirement to conduct a VE analysis is considered to be satisfied, or not necessary, if:
  - a. A project met the criteria identified above and had a VE analysis conducted, and the project advances to advertisement for construction without any substantial changes in its scope or its design; or
  - b. A project's estimated cost initially fell *below* the criteria identified above, but when advancing to advertisement for construction, falls *above* the criteria due to inflation, standard escalation of costs, or minor modifications to the project's design or contract.

Other projects that should be considered for value engineering have a total estimated cost exceeding \$5 million and include one or more of the following:

- Alternative solutions that vary the scope and cost
- New alignment or bypass sections
- Capacity improvements that widen the existing highway
- Major structures
- Interchanges
- Extensive or expensive environmental or geotechnical requirements
- Materials that are difficult to acquire or that require special efforts
- Inferior materials sources
- New/Reconstruction projects
- Major traffic control requirements or multiple construction stages

### 310.03(3) *VE Analysis Timing*

#### 310.03(3)(a) **When to Conduct the VE Analysis**

Timing is very important to the success of the VE analysis. A VE analysis should be conducted as early as practicable in the planning or development of a project, preferably before the completion of preliminary design. At a minimum, the VE analysis is to be conducted prior to completing the final design.

The VE analysis should be closely coordinated with other project development activities to minimize the impact approved recommendations might have on previous agency, community, or environmental commitments; the project's scope; and the use of innovative technologies, materials, methods, plans, or construction provisions. In addition, VE analyses should be coordinated with risk assessment workshops such as Cost Risk Assessment (CRA) or Cost Estimate Validation Process (CEVP) (see [www.wsdot.wa.gov/design/saeo/](http://www.wsdot.wa.gov/design/saeo/)).

Benefits can potentially be realized by performing a VE analysis at any time during project development; however, the WSDOT VE program identifies the following three windows of opportunity for performing a VE analysis.

#### 1. **Scoping Phase**

As soon as preliminary engineering information is available and the specific deficiencies or drivers are identified, the project scope and preliminary costs are under consideration. This is the best time to consider the various alternatives or design solutions with the highest potential for the VE team's recommendations to be implemented. At the conclusion of the VE study, the project scope, preliminary costs, and major design decisions can be based on the recommendations.

When conducting a study during the scoping phase of a project, the VE analysis focuses on issues affecting project drivers. This stage often provides an opportunity for building consensus with stakeholders.

#### 2. **Start of Design**

At the start of design, the project scope and preliminary costs have already been established and the major design decisions have been made. Some Plans, Specifications, and Estimates (PS&E) activities may have begun, and coordination has been initiated with the various service units that will be involved with the design. At this stage, the established project scope, preliminary costs, and schedule will define the limits of the VE analysis and there is still opportunity for the study to focus on the technical issues of the specific design elements.

#### 3. **Design Approval**

After the project receives Design Approval, most of the important project decisions have been made and the opportunity to affect the project design is limited. Provided that the Design Approval is early enough to incorporate the adopted VE recommendations, the VE analysis should focus on constructability, construction sequencing, staging, traffic control, and any significant design issues identified during design development.

An additional VE analysis may be beneficial late in the development stage when the estimated cost of the project exceeds the project budget. The value engineering process can be applied to the project to lower the cost while maintaining the value and quality of the design.



**310.03(4) VE Program Roles and Responsibilities****310.03(4)(a) Region VE Coordinator**

- Identifies region projects for VE analyses (from Project Summaries and available planning documents).
- Makes recommendations for timing of the VE analysis for each project.
- Presents a list of the identified projects to region management to prioritize into a regional annual VE Plan.
- Identifies potential team facilitators and members for participation statewide.

**310.03(4)(b) State VE Manager**

- Reviews regional VE Plans regarding content and schedule.

**310.03(4)(c) State VE Coordinator**

- Incorporates the regional annual VE Plans and the Headquarters Plan to create the Statewide VE Plan.
- Prepares annual VE Report.
- Maintains policy documents for the department.
- Coordinates studies.
- Arranges training for future VE team leaders and members.

**310.03(4)(d) VE Team Leader**

The quality of the VE analysis largely depends on the skills of the VE team leader. This individual guides the team's efforts and is responsible for its actions during the study. The VE team leader should be knowledgeable and proficient in transportation design and construction and in the VE analysis process for transportation projects.

The VE team leader's responsibilities include the following:

- Plans, leads, and facilitates the VE study.
- Ensures proper application of a value methodology.
- Follows the Job Plan.
- Guides the team through the activities needed to complete the pre-study, the VE study, and the post-study stages of a VE study.
- Schedules a pre-workshop meeting with the project team and prepares the agenda for the VE study.

Team leaders from within WSDOT are encouraged but not required to be certified by the Society of American Value Engineers (SAVE) as a Certified Value Specialist (CVS) or as a Value Methodology Practitioner (VMP). Team leadership can be supplied from within the region, from another region, or from Headquarters. A statewide pool of qualified team leaders is maintained by the State VE Coordinator, who works with the Region VE Coordinator to select the team leader.

When using consultant team leaders, SAVE certification is required.

### 310.03(4)(e) VE Team Members

The VE team is typically composed of five to ten people with diverse expertise relevant to the specific study. The team members may be selected from the regions; Headquarters; other local, state, or federal agencies; or the private sector.

Team members **are not** directly involved in the planning and development phases of the project and are selected based on the identified expertise needed to address the major functional areas and critical high-cost issues of the study. All team members must be committed to the time required for the study. It is desirable for team members to have attended Value Engineering Module 1 training before participating in a VE study.

## 310.04 VE Procedure

The VE analysis uses the Seven-Phase Job Plan shown in [Exhibit 310-1](#). A detailed discussion of how each phase is supposed to be conducted can be found in the document, *Value Methodology Standard and Body of Knowledge*, developed by SAVE International, The Value Society. This document can be downloaded at the SAVE website: [www.value-eng.org/](http://www.value-eng.org/)

### 310.04(1) Pre-Study Preparation

To initiate a VE study, the project manager submits a Request for Value Engineering Study form to the Region VE Coordinator at least two months before the proposed study date. The form is located on the WSDOT value engineering website:

[www.wsdot.wa.gov/design/valueengineering/tools/](http://www.wsdot.wa.gov/design/valueengineering/tools/)

The Region VE Coordinator then works with the State VE Coordinator to determine the team leader and team members for the VE study. Contacts are listed on the WSDOT value engineering website: [www.wsdot.wa.gov/design/valueengineering](http://www.wsdot.wa.gov/design/valueengineering)

The design team prepares a study package of project information for each of the team members. (A list of potential items is shown in [Exhibit 310-2](#).) The VE team members should receive this information at least one week prior to the study so they have time to review the material.

The region provides a facility and the equipment for the study (see [Exhibit 310-2](#)).

### 310.04(2) VE Analysis Requirements

The time required to conduct a VE analysis varies with the complexity and size of the project, but typically ranges from three to five days. The VE team leader working with the project manager will determine the best length for the study.

The VE analysis Final Report includes an executive summary; a narrative description of project information; the background, history, constraints, and controlling decisions; the VE team's focus areas; a discussion of the team's speculation and evaluation processes; and the team's final recommendations. All of the team's evaluation documentation, including sketches, calculations, analyses, and rationale for recommendations, is included in the Final Report. A copy of the Final Report is to be included in the Project File. The project manager will specify the number of copies to be provided to the project team. The State VE Manager also provides a copy of the report to the FHWA for projects on the National Highway System or federal-aid system.

Post-VE analysis activities include:

- Implementation and evaluation of the approved recommendations and their outcomes.
- Documentation of the reasons for not implementing approved recommendations.

*Note:* These post-analysis activities are conducted prior to the final design phase to ensure the recommendations are included in the final design or the reasons for not implementing the recommendations are included in the design documentation.

### **310.04(3) Resolution Phase (Phase 7 of the VE Study)**

As soon as possible, preferably no more than two weeks following the VE analysis, the project manager reviews and evaluates the VE team's recommendation(s). The project manager completes the VE Recommendation Approval form included in the Final Report and returns it to the Statewide VE Manager.

For each recommendation that is not approved or is modified by the project manager, the project manager provides justification in the form of a VE Decision Document. The VE Decision Document includes a specific response for each of the disapproved or modified recommendations. Responses include a summary statement containing the project manager's decision not to use the recommendations in the project.

The project manager sends the completed VE Recommendation Approval form and, if necessary, the VE Decision Document to the State VE Manager within three months following receipt of the Final Report or by September 1 of each year, whichever comes first, so the results can be included in WSDOT's annual VE Report to FHWA.

A VE Decision Document must be submitted and forwarded to the Director & State Design Engineer, Development Division, for review; the only time a VE Decision Document is not submitted is if all of the recommendations were adopted and implemented (in other words, no recommendations were rejected or modified).

## **310.05 Documentation**

Refer to [Chapter 300](#) for design documentation requirements.

The following value engineering documentation is required:

- **Project File** – Value Engineering Final Report
- **Design Documentation Package** – Value Engineering Recommendation Approval Form
- **Project File** – Value Engineering Decision Document

VE Study Phase	Job Plan
<b>1. Information Phase</b>	Gather project information, including project commitments and constraints. <ul style="list-style-type: none"> <li>• <i>Investigate technical reports and field data</i></li> <li>• <i>Develop team focus and objectives</i></li> </ul>
<b>2. Function Analysis Phase</b>	Analyze the project to understand the required functions. <ul style="list-style-type: none"> <li>• <i>Define project functions using active verb/measurable noun context</i></li> <li>• <i>Review and analyze these functions to determine which need improvement, elimination, or creation to meet project goals</i></li> </ul>
<b>3. Creative Phase</b>	Generate ideas on ways to accomplish the required functions that improve project performance, enhance quality, and lower project costs. <ul style="list-style-type: none"> <li>• <i>Be creative</i></li> <li>• <i>Brainstorm alternative proposals and solutions to lower project costs, improve project performance, and enhance quality</i></li> </ul>
<b>4. Evaluation Phase</b>	Evaluate and select feasible ideas for development. <ul style="list-style-type: none"> <li>• <i>Analyze design alternatives, technical processes, and life-cycle costs</i></li> </ul>
<b>5. Development Phase</b>	Develop the selected alternatives into fully supported recommendations. <ul style="list-style-type: none"> <li>• <i>Develop technical and economic supporting data to prove the benefits and feasibility of the desirable concepts</i></li> <li>• <i>Develop team recommendations (long-term as well as interim solutions)</i></li> </ul>
<b>6. Presentation Phase</b>	Present the VE recommendation to the project stakeholders. <ul style="list-style-type: none"> <li>• <i>Present the VE recommendation to the project team and region management in an oral presentation</i></li> <li>• <i>Provide a written report</i></li> </ul>
<b>7. Resolution Phase</b>	Evaluate, resolve, and implement all approved recommendations and document in the VE Recommendation Approval form and VE Decision document.
<b>Note:</b> Phases 1–6 are performed during the study; see <i>Value Standard and Body of Knowledge</i> for procedures during these steps.	

### Seven-Phase Job Plan for VE Studies

#### Exhibit 310-1

Project-Related Input* (Study Package)
Collision data
Aerial photos
Contour maps
Cross sections and profiles
Design file
Environmental documents
Estimates
Existing as-built plans
Geotechnical reports
Hydraulic Report
Land use maps
Large-scale aerial photographs
Plan sheets
Quadrant maps
Quantities
Right of way plans
Traffic data
Vicinity map

Study-Related Facilities and Equipment
AASHTO Green Book
Bridge list
Calculators
Computer / projector
<i>Design Manual</i>
Easel(s) and easel paper pads
Field tables
Marking pens
Masking and clear tape
Network computer access (if available)
Power strip(s) and extension cords
Room with a large table and adequate space for the team
Scales, straight edges, and curves
<i>Standard Plans</i>
<i>Standard Specifications</i>
State Highway Log
Telephone
Vehicle or vehicles with adequate seating to transport the VE team for a site visit**

\* Not all information listed may be available to the team, depending on the project stage.

\*\* If a site visit is not possible, provide video of the project.

### VE Analysis Team Tools

*Exhibit 310-2*



410.01	General
410.02	References
410.03	Control Monuments
410.04	Alignment Monuments
410.05	Property Corners
410.06	Other Monuments
410.07	Filing Requirements
410.08	Documentation

### 410.01 General

Proper monumentation is important in referencing a highway's alignment, which is used to define its right of way. The Washington State Department of Transportation (WSDOT) can contribute to the body of public records and minimize duplication of survey work by establishing and recording monuments that are tied to a state plane coordinate system and to a standard vertical datum. WSDOT is required by law to perpetuate existing recorded monuments ([Chapter 58.09 RCW](#)). The department provides monuments for realignments and new highway alignments and perpetuates existing monuments impacted by a project.

The Department of Natural Resources (DNR) is designated as the official agency for surveys and maps. New monuments set to establish property corners, highway alignment, and so on, shall be recorded on a Record of Survey or Monumentation Map and filed with the DNR Public Land Survey Office and the appropriate county auditor or county engineer. Records of Survey and Monumentation Maps are retained at DNR. Geodetic monuments are established and the Headquarters (HQ) GeoMetrix Office retains their placement records. Geodetic monuments are recorded on a Report of Survey Mark. These records are made available to the public on the following website: [www.wsdot.wa.gov/monument/](http://www.wsdot.wa.gov/monument/)

Existing monuments are not to be disturbed without first obtaining the DNR permits required by state law. DNR allows the temporary covering of a string of monuments under a single permit. State law requires replacement of land boundary monuments after temporary removal according to permit procedures. WSDOT control and alignment monuments may not be removed without replacement unless the location of the original position is perpetuated by reference and the appropriate document(s) prepared and filed with the county and the HQ Right of Way Plans Section. Other requirements pertaining to specific monuments are discussed below.

[Exhibit 410-1](#) summarizes the documentation requirements for new and existing monuments.

The region is responsible for identifying and locating existing monuments, obtaining required permits before any existing monument is disturbed, and conducting the research to locate existing monuments as required by [WAC 332-120-030](#), as follows:

*Any person, corporation, association, department, or subdivision of the state, county or municipality responsible for an activity that may cause a survey monument to be removed or destroyed shall be responsible for ensuring that the original survey point is perpetuated. It shall be the responsibility of the governmental agency or others performing construction work or other activity (including road or street resurfacing projects) to adequately search the records and the physical area of the proposed construction work or other activity for the purpose of locating and referencing any known or existing survey monuments.*

## 410.02 References

### 410.02(1) Federal/State Laws and Codes

[Chapter 18.43 Revised Code of Washington \(RCW\)](#), Engineers and land surveyors

[Chapter 58.09 RCW](#), Surveys – Recording

[Chapter 58.24 RCW](#), State agency for surveys and maps – Fees

[Chapter 332-120 Washington Administrative Code \(WAC\)](#), Survey monuments – Removal or destruction

[Chapter 332-130 WAC](#), Minimum standards for land boundary surveys and geodetic control surveys and guidelines for the preparation of land descriptions

### 410.02(2) Design Guidance

*Electronic Engineering Data Standards*

[www.wsdot.wa.gov/publications/manuals/m3028.htm](http://www.wsdot.wa.gov/publications/manuals/m3028.htm)

*Highway Surveying Manual*

[www.wsdot.wa.gov/publications/manuals/m22-97.htm](http://www.wsdot.wa.gov/publications/manuals/m22-97.htm)

*Manual of Instructions for the Survey of the Public Lands of the United States*, BLM, U.S. Department of the Interior, 1973

*Plans Preparation Manual*

[www.wsdot.wa.gov/publications/manuals/m22-31.htm](http://www.wsdot.wa.gov/publications/manuals/m22-31.htm)

## 410.03 Control Monuments

Horizontal and vertical control monuments are permanent references required for the establishment of project coordinates tied to the Washington State plane system and elevations tied to a standard vertical datum. By establishing and recording permanent control monuments, WSDOT eliminates duplication of survey work and contributes to the body of public records.

Provide the horizontal and vertical control monuments for highway projects that require the location of existing or proposed alignment or right of way limits. Monuments set by other agencies may be used if within 1 mile of the project and where the required datum and accuracy were used.

When control monuments are required for a given project, show the existing and proposed control monuments on the contract plans.

For horizontal control:

- Use North American Datum 1983, revised 1991 (NAD83/91).
- Use a minimum of second order, Class II procedures as defined in the [Highway Surveying Manual](#).
- Provide two monuments near the beginning of the project. Where possible, when setting horizontal control, set points to act as azimuth points. Place points so that line of sight is preserved between them and in an area that will not be disturbed by construction.
- Provide two monuments near the end of the project.
- Provide a pair of monuments at about 3-mile intervals throughout the length of the project.



For vertical control:

- Use North American Vertical Datum 1988 (NAVD88). (See the *Highway Surveying Manual* for orders of accuracy required.)
- Use at least second order procedures for primary vertical control within project limits as defined in the *Highway Surveying Manual*. Use third order for secondary control throughout the project.
- Provide vertical control throughout the length of the project. Desirable spacing is at or near each milepost. Maximum spacing is 3 miles apart.

All control monuments that are established, reestablished, or reset must be filed with the county engineer and the Department of Natural Resources (DNR). Submit a Record of Survey or a Monumentation Map that has been signed by the supervising, licensed, professional engineer or licensed, professional land surveyor. If the monument is not used to reference right of way or land corners, submit a Report of Survey Mark. (See the *Highway Surveying Manual* for more detailed guidance on Control Monuments.)

#### 410.04 Alignment Monuments

Alignment monuments are permanent references required for the establishment or reestablishment of the highway and its right of way. Placing monuments at random points, in safe locations and tied to the Washington State plane coordinate system is recommended (see the *Highway Surveying Manual*).

Establishment, reestablishment, or resetting of alignment monuments is required on the following highway projects:

- New highway alignment projects.
- Highway realignment projects involving new right of way (monuments are only required for the realigned highway section).
- Highway projects where alignment monuments already exist.

Before an existing alignment monument is reestablished or reset, a DNR permit is required.

All alignment monuments that are established, reestablished, or reset must be filed with the appropriate county auditor or county engineer. The Record of Survey is filed with the county auditor in the county in which the monument is located, and a recorded copy is sent to the HQ Right of Way Plans Section. The original Monumentation Map is filed with the county engineer of the county in which the monument is located, and a recorded copy, with the filing signatures, is sent to the HQ Right of Way Plans Section. The HQ Right of Way Plans Section will forward a copy to DNR for its records.

#### 410.05 Property Corners

A new property corner monument will be provided where an existing recorded monument, or an unrecorded monument set by a professional land surveyor (PLS) prior to the Recording Act of 1973 (*RCW 58.09*), has been invalidated as a direct result of a right of way purchase by the department. The property corner monument will be set on the new right of way line or at a point in reference thereto. Property corner monuments may also be set at the location of new acquisitions such as wetlands or stormwater mitigation sites or properties shown on Sundry Site Plans. The new property corner monument shall be set by or under the direct supervision of a licensed PLS.

When any property corner monument is set, the licensed land surveyor shall file a Record of Survey with the county auditor. A copy of the recorded Record of Survey is sent to the HQ Right of Way Plans Section and HQ Real Estate Services.

#### **410.06 Other Monuments**

A DNR permit is required before any monument may be removed or destroyed.

Existing section corners and BLM or GLO monuments impacted by a project shall be reset to perpetuate their existence. After completing the work, a DNR Land Corner Record is required.

Other permanent monuments established by any other governmental agency must not be disturbed until the agency has been contacted to determine specific requirements for the monument. If assistance is needed to identify a monument, contact the HQ GeoMetrix Office.

Resetting monuments must be done by or under the direct supervision of a licensed professional engineer or a licensed professional land surveyor. If a Record of Survey is prepared, it will be filed with the county auditor in the county in which the monument is located. If a Monumentation Map is prepared, it is filed with the county engineer in the county in which the monument is located, and a recorded copy is sent to the HQ Right of Way Plans Section. The HQ Right of Way Plans Section will forward a copy to DNR for its records.

#### **410.07 Filing Requirements**

##### **410.07(1) DNR Permit**

When a DNR permit is required, use the application form shown in [Exhibit 410-2](#). The completed application must be signed by a licensed professional engineer or a licensed professional land surveyor and submitted to DNR. The DNR permit applications can be downloaded in TIFF, PDF, or Word format at the following website:

[www.dnr.wa.gov/businesspermits/howto/landownersindustrycontractors/pages/eng\\_plso\\_forms.aspx](http://www.dnr.wa.gov/businesspermits/howto/landownersindustrycontractors/pages/eng_plso_forms.aspx)

Monumentation work cannot be done until DNR has approved the permit. In extraordinary circumstances, verbal authorization may be granted by DNR pending the issuance of a written permit.

After resetting the monument, the survey method used must be filed with DNR using the completion report form shown in [Exhibit 410-3](#). The form is to be signed by a licensed professional engineer or a licensed professional land surveyor.

##### **410.07(2) Monumentation Map**

When a Monumentation Map is required, a plan sheet is prepared. Generally, the plan sheet is based on a right of way plan obtained from the HQ Right of Way Plans Section. A Monumentation Map contains a description of all new and existing monuments indicating their kind, size, and location. In addition, it must contain the seal and signature of a licensed professional engineer or a licensed professional land surveyor (see the [Plans Preparation Manual](#)).

A copy of a Monumentation Map is filed with the county engineer in the county in which the monument is located, and a recorded copy is sent to the HQ Right of Way Plans Section. The HQ Right of Way Plans Section will forward a copy to DNR for its records.

**410.07(3) Land Corner Record**

When a Land Corner Record is required, use the forms shown in [Exhibit 410-4](#). The completed forms are to be signed and stamped by a licensed professional engineer or a licensed professional land surveyor and submitted to the county auditor for the county in which the monument is located.

**410.08 Documentation**

Refer to [Chapter 300](#) for design documentation requirements.

<b>SET NEW</b>
<p><b>WSDOT Control Monument</b></p> <p><b>Before:</b> No permit required.</p> <p><b>After:</b> File a copy of the Monumentation Map with the county engineer. Send the original to the HQ Right of Way Plans Section.</p> <p><b>Alignment Monument</b></p> <p><b>Before:</b> No permit required.</p> <p><b>After:</b> File a Record of Survey with the county auditor or a Monumentation Map with the county engineer. Send a copy to the HQ Right of Way Plans Section.</p> <p><b>Property Corner Monument*</b></p> <p><b>Before:</b> Engage a licensed professional land surveyor.</p> <p><b>After:</b> Licensed professional land surveyor files Record of Survey with county auditor, or a licensed professional engineer files a Monumentation Map with the county engineer and sends a copy to the HQ Right of Way Plans Section.</p>
<b>DISTURB EXISTING*</b>
<p><b>Control Monument</b></p> <p><b>Before:</b> Obtain DNR permit.</p> <p><b>After:</b> File a copy of the Monumentation Map with the county engineer. Send the original to the HQ Right of Way Plans Section.</p> <p><b>Alignment Monument</b></p> <p><b>Before:</b> Obtain DNR permit.</p> <p><b>After:</b> File a copy of the Monumentation Map with the county engineer. Send the original to the HQ Right of Way Plans Section.</p> <p><b>Section Corner, BLM, or GLO Monument</b></p> <p><b>Before:</b> Obtain DNR permit.</p> <p><b>After:</b> File Land Corner Record with the county engineer. Send a copy to the HQ Right of Way Plans Section.</p> <p><b>All Other Monuments</b></p> <p><b>Before:</b> Obtain DNR permit. Contact governmental agency.</p> <p><b>After:</b> File a copy of the Monumentation Map with the county engineer. Send the original to the HQ Right of Way Plans Section.</p>
<p>* Property corner monuments must be filed within 90 days of establishment, re-establishment, or restoration.</p>

**Monument Documentation Summary**  
*Exhibit 410-1*

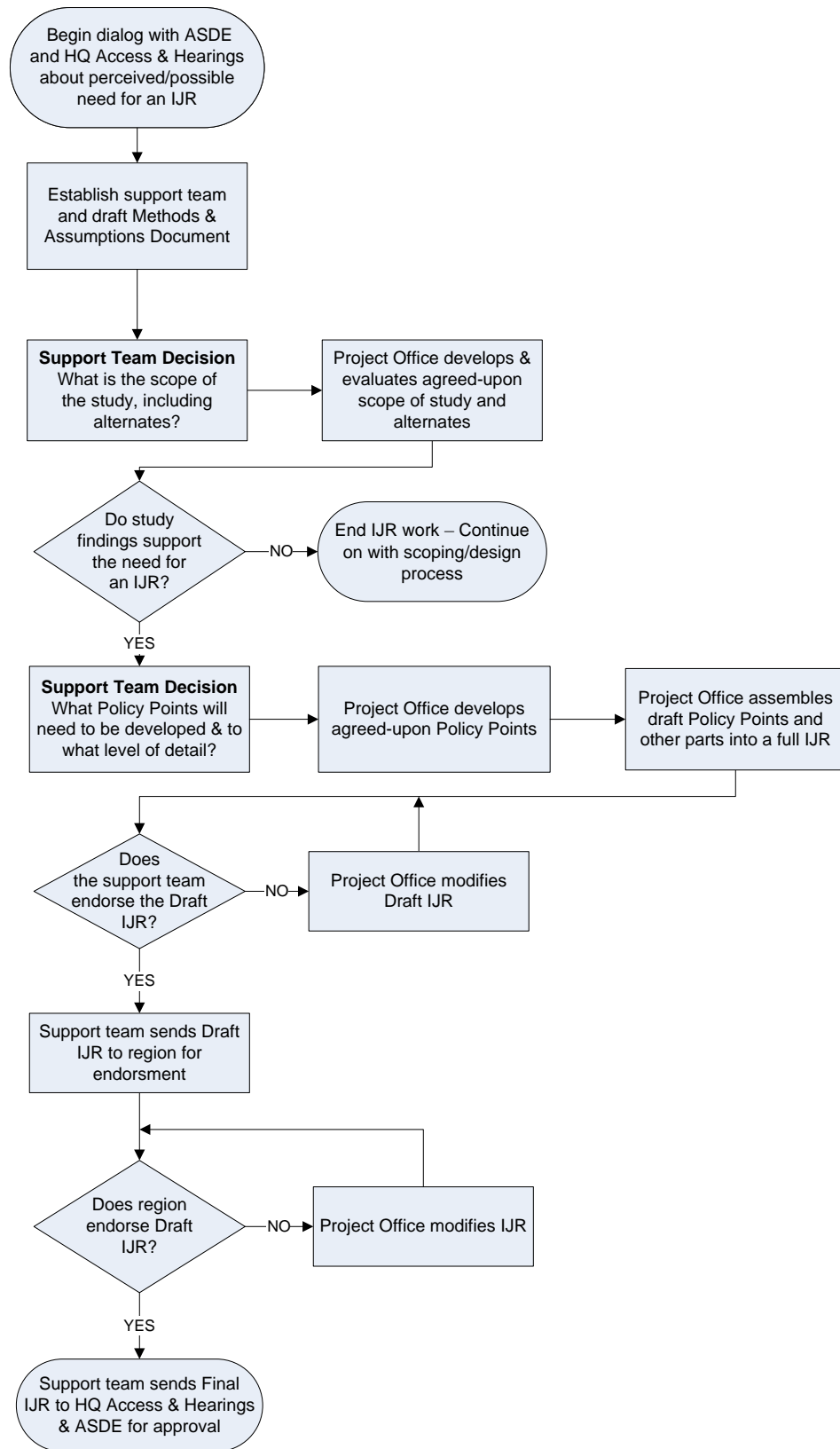

**Non-Interstate IJR: Process Flow Chart**  
 Exhibit 550-4

**Interchange Justification Report**

“Project Title”

“MP to MP”

This **Interchange Justification Report** has been prepared under my direct supervision, in accordance with Chapter 18.43 RCW and appropriate Washington State Department of Transportation manuals.

**IJR Engineer of Record**

By: \_\_\_\_\_ P.E.  
Project Engineer

Date: \_\_\_\_\_

**Traffic Analysis Engineer**

By: \_\_\_\_\_ P.E.  
Traffic Analysis Engineer

Date: \_\_\_\_\_

**Concurrence –  
Region Traffic Engineer**

By: \_\_\_\_\_ P.E.

Date: \_\_\_\_\_

**Concurrence –  
Project Development Engineer**

By: \_\_\_\_\_ P.E.

Date: \_\_\_\_\_

**WSDOT Approval –  
Development Services and  
Access Manager**

By: \_\_\_\_\_ P.E.

Date: \_\_\_\_\_

**WSDOT Approval –  
Assistant State Design Engineer**

By: \_\_\_\_\_ P.E.

Date: \_\_\_\_\_

**FHWA Approval –  
FHWA Safety and Design  
Engineer**

By: \_\_\_\_\_

Date: \_\_\_\_\_

**IJR: Stamped Cover Sheet Example**

*Exhibit 550-5*

Wetland mitigation sites are not normally fenced. When evaluating fencing for wetland mitigation sites, balance the need to restrict human access for safety considerations (such as the presence of children) with the need to provide animal habitat.

Other special sites where fencing may be required are addressed in the following chapters:

- [Chapter 720](#), Bridges (refers to protective screening)
- [Chapter 1510](#), Pedestrian Design Considerations
- [Chapter 1520](#), Bicycle Facilities

The fencing types and designs for special sites are determined by the requirements of each situation.

## 560.04 Fencing Types

### (1) Chain Link

Installation of chain link fence is appropriate for maximum protection against right of way encroachment on sections of high-volume highways in the following locations:

- Along existing business districts adjacent to a freeway.
- Between freeways and adjacent parallel city streets.
- Where existing streets have been cut off by freeway construction.
- In industrial areas.
- At large residential developments.
- On military reservations.
- At schools and colleges.
- In recreational and athletic areas.
- In developed areas at the intersection of two limited access highways.
- At any other location where a barrier is needed to protect against pedestrian, bicyclist, or livestock encroachment in limited access areas.

For roadway sections in rock cuts, see [Chapter 1230](#).

The *Standard Plans* contains details for the approved types of chain link fence. The recommended uses for each type of fence are as follows:

#### (a) Type 3

This is a high fence for areas of intensified use, such as industrial areas or school playgrounds. Use this fence for new installations of high fencing. It may be used within the Design Clear Zone.

#### (b) Type 4

This is a lower fence for special use, such as between the traveled highway lanes and a rest area or flyer stop or as a rest area boundary fence if required by the development of the surrounding area. This fence may be used along a bike path or hiking trail to separate it from an adjacent roadway.

Justify why corrective action is not taken when existing fencing with a rigid top rail will be left in place within the limits of a proposed project. For cases where a more rigid fence is needed, contact the HQ Design Office.

Coated galvanized chain link fence is available in various colors and may be considered in areas where aesthetic considerations are important. Coated ungalvanized chain link fence is not recommended.

## (2) **Wire Fencing**

The *Standard Plans* and the *Standard Specifications* contain details for the two approved types of wire fence. The recommended uses for each type of fence are as follows:

### (a) **Type 1**

This fence is used in urban and suburban areas where improvements along the right of way are infrequent and future development is not anticipated. It may also be used adjacent to livestock grazing areas. The lower portion of this fence is wire mesh and provides a barrier to children and small animals.

### (b) **Type 2**

This fence is used in farming areas to limit highway crossings by farm vehicles to designated approaches. These areas include irrigation districts to prevent ditch riders, maintenance personnel, and farmers from making unauthorized highway crossings, and where new alignment crosses parcels previously enclosed by barbed wire.

## (3) **Other Considerations**

Extremely tall fences (7 to 10 feet high) may be used in areas where there are exceptional conditions such as large concentrations of deer or elk. (See the region Environmental Services Office and the *Roadside Manual* concerning wildlife management.)

Metal fencing can interfere with airport traffic control radar. When locating fencing in the vicinity of an airport, contact the Federal Aviation Administration to determine whether metal fence will create radar interference at the airport. If so, use nonmetallic fencing.

Do not straddle or obstruct surveying monuments with any type of fencing.

## **560.05 Gates**

Keep the number of fence gates along limited access highways to a minimum. On limited access highways, all new gates must be approved as described in [Chapter 550](#).

Usually such gates are necessary only to allow highway maintenance personnel and operating equipment to reach the state right of way without using the highway or freeway main line. Gates may be needed to provide access to utility supports, manholes, and so on, located within the right of way.

Use gates of the same type as each fence, and provide locks to deter unauthorized use.

In highly developed and landscaped areas where maintenance equipment is parked outside the fence, provide the double gate shown in the *Standard Plans*.

Where continuous fencing is not provided on limited access highways (see [Chapter 530](#)), approaches are normally gated and locked, with a short section of fence on both sides of the gate.



- 610.01 General
- 610.02 References
- 610.03 Materials Sources
- 610.04 Geotechnical Investigation, Design, and Reporting
- 610.05 Use of Geotechnical Consultants
- 610.06 Geotechnical Work by Others
- 610.07 Surfacing Report
- 610.08 Documentation

### 610.01 General

It is the Washington State Department of Transportation's (WSDOT's) responsibility to understand the characteristics of the soil and rock materials that support or are adjacent to a transportation facility so that, when designed, constructed, and maintained, the facility will be adequate to safely carry the estimated traffic. It is also the responsibility of WSDOT to ensure the quality and quantity of all borrow, soils, rock, and surfacing materials used in the construction of transportation facilities. Specific requirements for geotechnical investigation, design, construction, and maintenance support are set forth in the WSDOT *Geotechnical Design Manual*.

The following information serves as guidance in the above areas. When a project consists of a surface overlay on an existing highway, the *WSDOT Pavement Policy* is used.

Before making project budget and schedule commitments to the Legislature, other agencies, and the public, it is necessary to identify the extent and estimated cost for a project. Contact the Region Materials Engineer (RME) and the Headquarters (HQ) Geotechnical Office as early as possible to obtain conceptual-level recommendations regarding how the project soil, rock, and groundwater conditions may affect the design of the project elements. The project soil, rock, and groundwater conditions, and the availability, quantity, and quality of borrow and surfacing materials, can affect the project scope, schedule, and budget.

The RME and the HQ Geotechnical Office will use existing subsurface information and their knowledge of the project area to assess the subsurface conditions within the project limits. If there is little information available or the information is poor, and the subsurface conditions have the potential to significantly affect the project budget or schedule, it may be necessary to obtain a limited number of geotechnical borings or test pits during Project Definition to assess soil, rock, and groundwater conditions within the project limits. Once the Project Definition has been developed and project funding secured, a more detailed geotechnical investigation follows during the design and Plans, Specifications, and Estimates (PS&E) phases.

It is essential to involve the RME and the HQ Geotechnical Office in the design as soon as possible once the need for geotechnical work is identified. (See [610.04\(3\)](#) for time-estimate information.) If major changes occur as the project is developed, inform the RME and the HQ Geotechnical Office as soon as possible so that the geotechnical design can be adapted to the changes without significant delay to the project.

---

Coordinate early in your project for geotechnical reporting and design.

---

## 610.02 References

### 610.02(1) Design Guidance

*Construction Manual*, M 41-01, WSDOT

*Geotechnical Design Manual*, M 46-03, WSDOT

*Hydraulics Manual*, M 23-03, WSDOT

*Plans Preparation Manual*, M 22-31, WSDOT

*Standard Plans for Road, Bridge, and Municipal Construction (Standard Plans)*, M 21-01, WSDOT

*Standard Specifications for Road, Bridge, and Municipal Construction (Standard Specifications)*, M 41-10, WSDOT

*WSDOT Pavement Policy* – See Pavements website:

[www.wsdot.wa.gov/business/materialslab/pavements/default.htm](http://www.wsdot.wa.gov/business/materialslab/pavements/default.htm)

## 610.03 Materials Sources

### 610.03(1) General

The region Project Development Engineer determines when a materials source is needed. The RME determines the best materials source for the project (see [Exhibit 610-1](#)). It is preferred that existing approved materials source sites be used when there are suitable sites available. When there are no approved sites available, the RME determines the locations for new materials sources. The RME contacts the HQ Geotechnical Office to provide a geotechnical investigation for the proposed site. The HQ Geotechnical Office provides geologic mapping of the site; develops a subsurface exploration plan and cost estimate; conducts the subsurface investigation; develops a subsurface geologic model including groundwater; evaluates slope stability issues; and makes recommendations. The HQ Geotechnical Office develops and provides a geotechnical report with materials source development recommendations to the RME. The RME uses this report and materials source recommendations to develop the Materials Source Report and to identify the quantity and quality of material that are intended for the life of the materials source.

Specific requirements for materials source investigations are set forth in the *Geotechnical Design Manual*.

### 610.03(2) Materials Source Approval

The HQ Geotechnical Office must review and approve the Materials Source Report produced by the RME to ensure consistency with the geotechnical report produced by the HQ Geotechnical Office.

The HQ Materials Office and the HQ Design Office must approve each pit or quarry site before it is purchased, leased, or acquired on a royalty basis. Until the approval process is complete, the project cannot be advertised for bids. Local and state permits are required for materials sources. To avoid delay in advertising the project, begin the site investigations and permitting process in the early stages of the Project Definition phase.

## 610.04 Geotechnical Investigation, Design, and Reporting

### 610.04(1) General

A geotechnical investigation is conducted on all projects that involve significant grading quantities (including state-owned materials source development), unstable ground, foundations for structures, and groundwater impacts (including infiltration). The goal of the geotechnical investigation is to preserve the safety of those who use the facility, as well as to preserve the economic investment by the state of Washington. Additional requirements regarding geotechnical investigations and who conducts these investigations are set forth in the *Geotechnical Design Manual*.

### 610.04(2) Key Contacts for Initiating Geotechnical Work

For regions, the RME is the first person to contact for geotechnical work. Projects with structures designed by the HQ Bridge and Structures Office, Washington State Ferries (WSF) projects, and Urban Corridors projects generally require the involvement of the HQ Geotechnical Office. These particular WSDOT offices should contact the HQ Geotechnical Office directly for their geotechnical project needs. The specific roles and responsibilities of the RME and HQ Geotechnical Office, including application to the Project Management Process (PMP), are set forth in the *Geotechnical Design Manual*.

For information on retaining walls and noise walls, see *Design Manual* Chapters 730 and 740, respectively. For geosynthetic design, see [Chapter 630](#).

### 610.04(3) Scheduling Considerations for Geotechnical Work

The region Project Office, the HQ Bridge and Structures Office, the WSF, and the HQ Facilities Office are responsible for identifying the potential need for geotechnical work and requesting time and budget estimates from the RME or the HQ Geotechnical Office as early as possible to prevent delays to the project.

Once the geotechnical design request and the site data are received by the RME or the HQ Geotechnical Office, it can take from two to six months or more to complete the geotechnical design. Design completion depends on the complexity of the project, whether or not test holes are needed, current workload, the need to give the work to consultants, and how long it takes to obtain environmental permits and rights of entry.

If a consultant must be used, the minimum time required to complete a design (for even a simple project) is typically two and a half months.

In true emergency situations (such as a highway blocked by a landslide or a collapsed bridge), it is possible to get geotechnical design work completed (in-house or by consultants) more rapidly to at least provide a design for temporary mitigation.

Consider all of these factors when deciding how soon (in general, as early as possible) to initiate the geotechnical work for a project.

To incorporate geotechnical scheduling considerations into the overall project schedule, see the *Geotechnical Design Manual*, which provides a description and discussion of the Master Deliverables List (MDL) as it applies to geotechnical work.

**610.04(4) Site Data and Permits Needed to Initiate Geotechnical Work****610.04(4)(a) Geotechnical Work During Project Definition Phase**

To initiate geotechnical work on a project during the Project Definition phase, provide the following information:

1. Project description.
2. Plan view or description showing the proposed alignment or alignment alternative(s).
3. Description of project scope as it relates to geotechnical features such as major cuts and fills, walls, structures, and potential stormwater facilities.

**610.04(4)(b) Geotechnical Work During Design and PS&E Phases**

To initiate geotechnical work on a project during the design and PS&E phases, provide the following information:

1. Project description.
2. Plan sheets showing:
  - Station and location of cuts, fills, walls, bridges, retention/detention ponds, and other geotechnical features to be designed.
  - Existing utilities; as-built plans are acceptable.
  - Right of way limits.
  - Wetlands.
  - Drainage features.
  - Existing structures.
  - Other features or constraints that could affect the geotechnical design or investigation.
3. Electronic files, or cross sections every 50 feet or as appropriate, to define existing and new ground line above and below walls, cuts, fills, and other pertinent information.
  - Show stationing.
  - Show locations of existing utilities, right of way lines, wetlands, and other constraints.
  - Show locations of existing structures that might contribute load to the cut, fill, wall, or other structure.
4. Right of entry agreements and permits required for geotechnical investigation.
5. Due date and work order number.
6. Contact person.

When the alignment and any constraints (as noted above) are staked, the stationing on the plans and in the field must be in the same units. Physical surveys are preferred to photogrammetric surveys to ensure adequate accuracy of the site data.

Permits and agreements to be supplied by the region might include the following:

- HPA
- Shoreline permits
- Tribal lands and waters
- Railroad easement and right of way
- City, county, or local agency use permits
- Sensitive area ordinance permits

The region Project Office is also responsible for providing survey locations of test holes once the test holes have been drilled. The survey information includes the station, offset, elevation, and test hole coordinates. Coordinates are the latitude and longitude or state plane coordinates (north or south as appropriate), but not project coordinates.

### **610.04(5) Overview of Geotechnical Design Objectives for the Various Project Stages**

Geotechnical design objectives for the various design phases are described in the *Geotechnical Design Manual*.

### **610.04(6) Earthwork**

#### **610.04(6)(a) Project Definition**

The designer contacts and meets with the RME (and the HQ Geotechnical Office as needed) at the project site to conduct a field review to help identify the geotechnical issues for the project.

In general, if soil/rock conditions are poor and/or large cuts or fills are anticipated, the RME requests that the HQ Geotechnical Office participate in the field review and reporting efforts.

The designer provides a description and location of the proposed earthwork to the RME as follows:

- For widening of existing facilities, the anticipated width, length, and location of the widening, relative to the current facility, are provided.
- For realignments, the approximate new location proposed for the facility is provided.
- Locations in terms of length can be by milepost or stations.

A brief conceptual-level report that summarizes the results of the investigation is provided to the designer.

#### **610.04(6)(b) Project Design**

Geotechnical data necessary to allow completion of the PS&E-level design is compiled during the design phase. This includes soil borings, testing, and geotechnical design based on final geometric data. Detailed design of cut and fill slopes can be done once the roadway geometry is established and geotechnical data are available. The purpose of this design effort is to determine the maximum stable cut or fill slope and, for fills, the potential for short- and long-term settlement. Also, the usability of the cut materials and the type of borrow needed for the project (if any) are evaluated. Evaluate the use of soil bioengineering as an option for building steeper slopes or to prevent surface erosion. (See [Chapter 940](#), Soil Bioengineering, for more information.)

The designer requests a geotechnical report from the RME. The site data given in 610.04(4), as applicable, is provided. It is important that the request for the geotechnical report be made as early as possible in the design phase. Cost and schedule requirements to generate the report are project-specific and can vary widely. The time required to obtain permits and rights of entry must be considered when establishing schedule requirements.

The *Geotechnical Design Manual*, Chapter 24, summarizes the type of information and recommendations that are typically included in the geotechnical report for earthwork. The recommendations should include the background regarding analysis approach and any agreements with the region or other customers regarding the definition of acceptable level of risk.

The region Project Office uses the report to finalize design decisions for the project. To meet slope stability requirements, additional right of way might be required or a wall might be needed. Wall design is covered in [Chapter 730](#). Construction timing might require importing material rather than using cut materials. The report is used to address this and other constructibility issues. The report is also used to proceed with completion of the PS&E.

#### **610.04(6)(c) PS&E Development**

Adequate geotechnical design information to complete the PS&E is typically received during the design phase. Additional geotechnical work might be needed when right of way cannot be acquired, restrictions are included in permits, or other requirements are added that result in changes to the design.

Special provisions and plan details, if not received as part of the report provided during design, are developed with the assistance of the RME or the HQ Geotechnical Office. The designer uses this information, as well as the design phase report, to complete the PS&E documents. Both the region Materials Laboratory and the HQ Geotechnical Office can review (if requested) the contract plans before the PS&E review process begins. Otherwise, they will review the contract plans during the normal PS&E review process.

#### **610.04(7) Hydraulic Structures, Ponds, and Environmental Mitigation**

##### **610.04(7)(a) Project Definition**

The designer provides a description and location of the proposed hydraulic/ environmental improvements and other pertinent site information and discusses the extent of the improvements with both the RME and the HQ Hydraulics Section to identify the geotechnical issues to be investigated. At this stage, only the identification and feasibility of the proposed hydraulic structures or environmental mitigation are investigated. The cost and schedule requirements for the geotechnical investigation are also determined at this time.

Examples of hydraulic structures include, but are not limited to, large culverts, pipe arches, underground detention vaults, and fish passage structures. Examples of environmental mitigation include, but are not limited to, detention/retention ponds, wetland creation, and environmental mitigation measures on fill slopes.

It is especially important to identify the potential to encounter high groundwater at the proposed hydraulic structure or pond location. In general, avoid high groundwater locations (see the [Highway Runoff Manual](#)) as groundwater can greatly affect design, constructibility, operations, performance, and maintenance.

##### **610.04(7)(b) Project Design**

The designer requests a geotechnical report from the RME. The site data given in 610.04(4), as applicable, is provided along with the following information:

- Pertinent field observations (such as unstable slopes, existing soft soils or boulders, evidence of high groundwater, or erosion around and damage to existing culverts or other drainage structures).
- Jurisdictional requirements for geotechnical design of berms/dams.

It is important that the request for the geotechnical report be made as early as possible in the design phase. Cost and schedule requirements to generate the report are project-specific and can vary widely. The time required to obtain permits and rights of entry must be considered when establishing schedule requirements. Furthermore, since the depth to groundwater can be critical to the feasibility of these types of facilities, and since seasonal variation of groundwater

is typically important to know, it is essential to have adequate time to determine the effect of seasonal variations on groundwater.

The RME, with support from the HQ Geotechnical Office as needed, provides the following information in addition to the overall requirements specified in the *Geotechnical Design Manual*, when requested and where applicable, as part of the project geotechnical report:

- Soil boring logs.
- Soil pH and resistivity.
- Water table elevation.
- Soil infiltration rates (the highest rate for assessing spill containment/aquifer protection and the long-term rate for determining pond capacity).
- Bearing capacity and settlement for hydraulic structure foundations.
- Slope stability for ponds.
- Retention berm/dam design.
- Potential for and amount of differential settlement along culverts and pipe arches and the estimated time required for settlement to occur.
- Soil pressures and properties (primarily for underground detention vaults).
- Erosion potential.
- Geosynthetic design in accordance with [Chapter 630](#).
- Recommendations for mitigation of the effects of soft or unstable soil on the hydraulic structures.
- Recommendations for construction.

Note that retaining walls that are part of a pond, fish passage, and so on, are designed in accordance with [Chapter 730](#) and the *Geotechnical Design Manual*.

The designer uses the geotechnical information to:

- Finalize design decisions.
- Evaluate and mitigate environmental issues.
- Proceed with completion of the PS&E design. This includes determining the most cost-effective hydraulic structure/pond to meet the desired objectives; locating and sizing ponds and foundations for hydraulic structures; structural design; mitigating the effects of settlement; and satisfying local jurisdictional requirements for design.

#### **610.04(7)(c) PS&E Development**

During PS&E development, the designer uses the information provided in the geotechnical report to:

- Select pipe materials in accordance with corrosion, resistivity, and abrasion guidelines in the *Hydraulics Manual*.
- Consider and include construction recommendations.

Additional design and specification guidance and support from the RME or the HQ Geotechnical Office are sought as needed. Both sections provide careful review of the contract plans before the PS&E review process begins, if requested. Otherwise, they will review the contract plans during the normal PS&E review process.

## **610.04(8) Signals, Sign Bridges, Cantilever Signs, and Luminaire Foundations**

### **610.04(8)(a) Project Definition and Design**

Geotechnical information is usually not required for signals, sign bridges, cantilever signs, and luminaires during Project Definition.

The region Traffic Design Office contacts the RME for conceptual foundation recommendations. The conceptual recommendations are based on existing information in the area and identify whether Standard Plan foundations are feasible or whether special-design foundations are required. If good soils are anticipated or the foundations will be placed in fill, Standard Plan foundations can be assumed. If special-design foundations are required, additional time and money can be included in the project to accommodate increased field exploration for foundation design, HQ Geotechnical Office involvement, and structural design by the HQ Bridge and Structures Office.

### **610.04(8)(b) PS&E Development**

Foundation recommendations are made by either the RME or the HQ Geotechnical Office. The recommendations provide all necessary geotechnical information to complete the PS&E.

The region Traffic Design Office (or region Project Engineer in some cases) is responsible for delivering the following project information to the RME:

- Plan sheet showing the location of the structures (station and offset) and the planned structure type.
- Applicable values for: XYZ coordinates, strain pole class, sign bridge span length, luminaire height, variable message sign weight, wind load, CCTV pole height, and known utility information in the area.

The RME provides the following information to the requester if *Standard Plans* foundation types can be used:

- Allowable lateral bearing capacity of the soil
- Results of all field explorations
- Groundwater elevation
- Foundation constructibility

The region uses this information to complete the plan sheets and prepare any special provisions. If utilities are identified during the field investigation that could conflict with the foundations, the region pursues moving or accommodating the utility. Accommodation could require special foundation designs.

If special designs are required, the RME notifies the requester that special designs are required and forwards the information received from the region to the HQ Geotechnical Office. The HQ Geotechnical Office provides the HQ Bridge and Structures Office with the necessary geotechnical recommendations to complete the foundation designs. The region coordinates with the HQ Bridge and Structures Office to ensure they have all the information necessary to complete the design. Depending on the structure type and complexity, the HQ Bridge and Structures Office might produce the plan sheets and special provisions for the foundations, or they might provide the region with information so they can complete the plan sheets and special provisions.

Additional guidelines and requirements for design of foundations for these types of structures are contained in the *Geotechnical Design Manual*.



**610.04(9) Buildings, Park & Ride Lots, Communication Towers, and Rest Areas**

In general, the RME functions as the clearinghouse for the geotechnical work to be conducted in each of the phases, for technical review of the work if it is performed by consultants, or for getting the work done in-house. For sites and designs that are more geotechnically complex, the RME contacts the HQ Geotechnical Office for assistance. (See the *Geotechnical Design Manual* for geotechnical investigation and design requirements for these types of facilities.)

Detailed geotechnical investigation guidance is provided in Facilities Operating Procedure 9.18, “Site Development”: <http://wwwi.wsdot.wa.gov/maintops/facilities/newpdf/sitedevelopmentprocedure.pdf>

In summary, this guidance addresses the following phases of design:

**610.04(9)(a) Site Selection**

Conceptual geotechnical investigation (based on historical data and minimal subsurface investigation) of several alternative sites is performed in which the geotechnical feasibility of each site for its intended use is evaluated, allowing the sites to be ranked. In this phase, geological hazards (such as landslides, rockfall, compressible soils, and liquefaction) are identified, and geotechnical data adequate to determine a preliminary cost to develop and build on the site is gathered.

**610.04(9)(b) Schematic Design**

For the selected site, the best locations for structures, utilities, and other elements of the project are determined based on site constraints and ground conditions. In this phase, the site is characterized more thoroughly than in the site selection phase, but subsurface exploration is not structure specific.

**610.04(9)(c) Design and PS&E Development**

The final locations of each of the project structures, utilities, and other project elements determined from the schematic design phase are identified. Once these final locations are available, a geotechnical investigation is conducted that is adequate to complete the final design of each of the project elements, such as structure foundations, detention/retention facilities, utilities, parking lots, roadways, and site grading. From this investigation and design, the final PS&E is developed.

**610.04(10) Retaining Walls, Reinforced Slopes, and Noise Walls****610.04(10)(a) Project Definition**

The designer provides the RME with a description and location of the proposed walls or reinforced slopes, including the potential size of the proposed structures and other pertinent site information. At this stage, only the identification and feasibility of the proposed walls or reinforced slopes are investigated. A field review may also be conducted as part of the investigation effort. In general, if soil/rock conditions are poor and/or large walls or reinforced slopes are anticipated, the RME requests that the HQ Geotechnical Office participate in the field review and reporting efforts. The cost and schedule requirements for the geotechnical investigation are also determined at this time.

A brief conceptual-level report that summarizes the results of the investigation may be provided to the designer at this time, depending on the complexity of the geotechnical issues.

### 610.04(10)(b) Project Design and PS&E Development

Geotechnical data necessary to allow completion of the PS&E-level design for walls and reinforced slopes are compiled during the design and PS&E development phases. These include soils borings, testing, and final geometric data. Detailed designs of walls and reinforced slopes can be done once the roadway geometry is established and geotechnical data are available. The purpose of this design effort is to determine the wall and slope geometry needed for stability; noise wall and retaining wall foundation requirements; and the potential for short- and long-term settlement.

The designer requests a geotechnical report from the RME for retaining walls, noise walls, and reinforced slopes that are not part of the bridge preliminary plan. For walls that are part of the bridge preliminary plan, the HQ Bridge and Structures Office requests the geotechnical report for the walls from the HQ Geotechnical Office. (See [Chapter 730](#) for the detailed design process for retaining walls and reinforced slopes, [Chapter 740](#) for the detailed design process for noise walls, and the *Geotechnical Design Manual* for design requirements for all walls.) It is important that requests for a geotechnical report be made as early as possible in the design phase. The time required to obtain permits and rights of entry must be considered when establishing schedule requirements.

For retaining walls and reinforced slopes, the site data to be provided with the request for a geotechnical report are as given in [Chapter 730](#). Supply right of entry agreements and permits required for the geotechnical investigation. The site data given in [610.04\(4\)](#), as applicable, are provided for noise walls.

The RME or the HQ Geotechnical Office provides the information (see [Chapter 730](#) or [740](#) for specific responsibilities for design) specified in the *Geotechnical Design Manual* as part of the project geotechnical report.

The recommendations may also include the background regarding the analysis approach and any agreements with the region or other customers regarding the definition of acceptable level of risk. Additional details and design issues to be considered in the geotechnical report are as provided in [Chapter 1130](#) for retaining walls and reinforced slopes and in [Chapter 740](#) for noise walls. The designer uses this information for final wall/reinforced slope selection and to complete the PS&E.

For final PS&E preparation, special provisions and plan details (if not received as part of the report provided during design) are developed with the assistance of the region Materials Laboratory or the HQ Geotechnical Office. Both the region Materials Laboratory and the HQ Geotechnical Office can review the contract plans before the PS&E review process begins, if requested. Otherwise, they will review the contract plans during the normal PS&E review process.

### 610.04(11) Unstable Slopes

Unstable slope mitigation includes the stabilization of known landslides and rockfall that occur on slopes adjacent to the WSDOT transportation system and that have been programmed under the P3 Unstable Slope Program.

#### 610.04(11)(a) Project Definition

The region Project Office provides the RME with a description and location of the proposed unstable slope mitigation work. Location of the proposed work can be milepost limits or stationing. The designer meets at the project site with the RME and HQ Geotechnical Office to conduct a field review, discuss project requirements, and identify geotechnical issues associated with the unstable slope project. The RME requests that the HQ Geotechnical Office participate in the field review and Project Definition reporting.

The level of work in the Project Definition phase for unstable slopes is conceptual in nature, not a final design. The geotechnical investigation generally consists of a field review, a more detailed assessment of the unstable slope, review of the conceptual mitigation developed during the programming phase of the project, and proposed modification (if any) to the original conceptual-level unstable slope mitigation. The design phase geotechnical services cost and schedule, including any required permits, are determined at this time. A brief conceptual-level report is provided to the designer that summarizes the results of the Project Definition investigation.

#### **610.04(11)(b) Project Design**

Geotechnical information and field data necessary to complete the unstable slope mitigation design is compiled during this design phase. This work includes, depending on the nature of the unstable slope problem, test borings, rock structure mapping, geotechnical field instrumentation, laboratory testing, and slope stability analysis. The purpose of this design effort is to provide design-level geotechnical recommendations to stabilize the known unstable slope.

The designer requests a geotechnical report from the HQ Geotechnical Office through the RME. The site data given in [610.04\(4\)](#), as applicable, is provided along with the following information:

- A plan sheet showing the station and location of the proposed unstable slope mitigation project.
- If requested, the Digital Terrain Model (DTM) files necessary to define the on-ground topography of the project site (the limits of the DTM will have been defined during the Project Definition phase).

It is important that the request for the geotechnical report be made as early as possible in the design phase. Cost and schedule requirements to generate the report are project-specific and can vary widely. Unstable slope design investigations might require geotechnical monitoring of ground movement and groundwater over an extended period of time to develop the required field information for the unstable slope mitigation design. The time required to obtain rights of entry and other permits, as well as the long-term monitoring data, must be considered when establishing schedule requirements for the geotechnical report.

In addition to the geotechnical report requirements specified in the *Geotechnical Design Manual*, the HQ Geotechnical Office provides the following information as part of the project geotechnical report (as applicable):

- Unstable slope design analysis and mitigation recommendations.
- Constructibility issues associated with the unstable slope mitigation.
- Appropriate special provisions for inclusion in the contact plans.

The region Project Office uses the geotechnical report to finalize the design decisions for the project and the completion of the PS&E design.

#### **610.04(11)(c) PS&E Development**

Adequate geotechnical design information to complete the PS&E is typically obtained during the project design phase. Additional geotechnical work might be needed when right of way cannot be acquired, restrictions are included in permits, or other requirements are added that result in changes to the design.

Special provisions, special project elements, and design details, if not received as part of the design phase geotechnical report, are developed with the assistance of the RME and the HQ Geotechnical Office. The designer uses this information in conjunction with the design phase geotechnical report to complete the PS&E document. The RME and the HQ Geotechnical Office can review the contract plans before the PS&E review begins, if requested. Otherwise, they will review the contract plans during the normal PS&E review process.

## **610.04(12) Rockslope Design**

### **610.04(12)(a) Project Definition**

The region Project Office provides the RME with a description and location of the proposed rock excavation work. For widening of existing rock cuts, the anticipated width and length of the proposed cut in relationship to the existing cut are provided. For new alignments, the approximate location and depth of the cut are provided. Location of the proposed cut(s) can be milepost limits or stationing. The designer meets at the project site with the RME and the HQ Geotechnical Office to conduct a field review, discuss project requirements, and identify any geotechnical issues associated with the proposed rock cuts. The RME requests that the HQ Geotechnical Office participate in the field review and Project Definition reporting.

The level of rockslope design work for the Project Definition phase is conceptual in nature. The geotechnical investigation generally consists of the field review, review of existing records, an assessment of existing rockslope stability, and preliminary geologic structure mapping. The focus of this investigation is to assess the feasibility of the rock cuts for the proposed widening or realignment, not final design. A brief conceptual-level report that summarizes the result of the Project Definition investigation is provided to the designer.

### **610.04(12)(b) Project Design**

Detailed rockslope design is done once the roadway geometrics have been established. The rockslope design cannot be finalized until the roadway geometrics have been finalized. Geotechnical information and field data necessary to complete the rockslope design are compiled during this design phase. This work includes rock structure mapping, test borings, laboratory testing, and slope stability analysis. The purpose of this design effort is to determine the maximum stable cut slope angle and any additional rockslope stabilization measures that could be required.

The designer requests a geotechnical report from the HQ Geotechnical Office through the RME. The site data given in 610.04(4), as applicable, is provided.

It is important that the request for the geotechnical report be made as early as possible in the design phase. Cost and schedule requirements to generate the report are project-specific and can vary widely. The time required to obtain permits and rights of entry must be considered when establishing schedule requirements.

In addition to the geotechnical report requirements specified in the *Geotechnical Design Manual*, the HQ Geotechnical Office provides the following information as part of the project geotechnical report pertaining to rockslope design analysis and recommendations:

- Type of rockslope design analysis conducted and limitation of the analysis. Also included will be any agreements with the region and other customers regarding the definition of “acceptable risk.”
- The slope(s) required for stability.
- Additional slope stabilization requirements (such as rock bolts or rock dowels).
- Rockslope ditch criteria (see [Chapter 1230](#)).
- Assessment of rippability.

- Blasting requirements, including limitations on peak ground vibrations and air blast over-pressure if required.
- Usability of the excavated material, including estimates of shrink and swell.
- Constructibility issues associated with the rock excavation.

The region Project Office uses the geotechnical report to finalize the design decisions for the project and the completion of the PS&E design for the rockslope elements of the project.

#### **610.04(12)(c) PS&E Development**

Adequate geotechnical design information to complete the PS&E is typically obtained during the design phase. Additional geotechnical work might be needed when right of way cannot be acquired, restrictions are included in permits, or other requirements are added that result in change to the design.

Special provisions, special blasting requirements, and plan details, if not received as part of the design phase geotechnical report, are developed with the assistance of the RME or the HQ Geotechnical Office. The designer uses this information in conjunction with the design phase geotechnical report to complete the PS&E documents. The RME and the HQ Geotechnical Office can review (if requested) the contract plans before the PS&E review begins. Otherwise, they will review the contract plans during the normal PS&E review process.

#### **610.04(13) Bridge Foundations**

##### **610.04(13)(a) Project Definition**

The HQ Geotechnical Office supports the development of reasonably accurate estimates of bridge substructure costs beginning with the Project Definition phase. A field review is recommended for major projects and projects that are located in areas with little or no existing geotechnical information. The region office responsible for Project Definition coordinates field reviews. Subsurface exploration (drilling) is usually not required at this time, but might be needed if cost estimates cannot be prepared within an acceptable range of certainty.

Once it has received the necessary site data from the region Project Office, the HQ Bridge and Structures Office is responsible for delivering the following project information to the HQ Geotechnical Office:

- Alternative alignments and/or locations of bridge structures.
- A preliminary estimate of channelization (structure width).
- Known environmental constraints.

The HQ Geotechnical Office provides the following to the HQ Bridge and Structures and region offices:

- Summary of existing geotechnical information.
- Identification of geotechnical hazards (such as slides, liquefiable soils, and soft-soil deposits).
- Identification of permits that might be required for subsurface exploration (drilling).
- Conceptual foundation types and depths.
- If requested, an estimated cost and time to complete a geotechnical foundation report.

The HQ Bridge and Structures Office uses this information to refine preliminary bridge costs. The region Project Office uses the estimated cost and time to complete a geotechnical foundation report to develop the project delivery cost and schedule.

**610.04(13)(b) Project Design**

The HQ Geotechnical Office assists the HQ Bridge and Structures Office with preparation of the bridge preliminary plan. Geotechnical information gathered for Project Definition will normally be adequate for this phase, as test holes for the final bridge design cannot be drilled until accurate pier location information is available. For selected major projects, a type, size, and location (TS&L) report might be prepared, which usually requires some subsurface exploration to provide a more detailed, though not final, estimate of foundation requirements.

The HQ Bridge and Structures Office is responsible for delivering the following project information, based on bridge site data received from the region Project Office, to the HQ Geotechnical Office:

- Anticipated pier locations.
- Approach fill heights.
- For TS&L, alternate locations/alignments/structure types.

The HQ Bridge and Structures Office can expect to receive the following:

- Conceptual foundation types, depths, and capacities.
- Permissible slopes for bridge approaches.
- For TS&L, a summary of site geology and subsurface conditions, and more detailed preliminary foundation design parameters and needs.
- If applicable or requested, the potential impact of erosion or scour potential (determined by the HQ Hydraulics Section) on foundation requirements.

The HQ Bridge and Structures Office uses this information to complete the bridge preliminary plan. The region Project Office confirms right of way needs for approach embankments. For TS&L, the geotechnical information provided is used for cost estimating and preferred alternate selection. The preliminary plans are used by the HQ Geotechnical Office to develop the site subsurface exploration plan.

**610.04(13)(c) PS&E Development**

During this phase, or as soon as a 95% preliminary plan is available, subsurface exploration (drilling) is performed and a geotechnical foundation report is prepared to provide all necessary geotechnical recommendations needed to complete the bridge PS&E.

The HQ Bridge and Structures Office is responsible for delivering the following project information to the HQ Geotechnical Office:

- 95% preliminary plans, concurrent with distribution for region approval.
- Estimated foundation loads and allowable settlement criteria for the structure when requested.

The HQ Bridge and Structures Office can expect to receive:

- The bridge geotechnical foundation report.

The HQ Bridge and Structures Office uses this information to complete the bridge PS&E. The region Project Office reviews the geotechnical foundation report for construction considerations and recommendations that might affect region items, estimates, staging, construction schedule, or other items.

Upon receipt of the structure PS&E review set, the HQ Geotechnical Office provides the HQ Bridge and Structures Office with a Summary of Geotechnical Conditions for inclusion in Appendix B of the contract.

**610.04(14) Geosynthetics**

For design guidance on geosynthetics, refer to [Chapter 630](#).

**610.04(15) Washington State Ferries Projects****610.04(15)(a) Project Design**

The HQ Geotechnical Office assists the Washington State Ferries (WSF) with determining the geotechnical feasibility of all offshore facilities, terminal facility foundations, and bulkhead walls. For upland retaining walls and grading, utility trenches, and pavement design, the RME assists WSF with determining geotechnical feasibility.

In addition to the site data provided in Section [610.04\(4\)](#), as applicable, the following information is supplied by WSF to the HQ Geotechnical Office or the RME, as appropriate, with the request for the project geotechnical report:

- A plan showing anticipated structure locations as well as existing structures.
- Relevant historical data for the site.
- A plan showing utility trench locations.
- Anticipated utility trench depths.
- Proposed roadway profiles.

WSF can expect to receive the following:

- Results of any borings or laboratory tests conducted.
- A description of geotechnical site conditions.
- Conceptual foundation types, depths, and capacities.
- Conceptual wall types.
- Assessment of constructibility issues that affect feasibility.
- Surfacing depths and/or pavement repair and drainage schemes.
- If applicable or requested, potential impact of erosion or scour potential (determined by the HQ Hydraulics Section) on foundation requirements.

WSF uses this information to complete the design report, design decisions, and estimated budget and schedule.

WSF is responsible for obtaining any necessary permits or right of entry agreements needed to access structure locations for the purpose of subsurface exploration (such as test hole drilling). The time required for obtaining permits and rights of entry must be considered when developing project schedules. Possible permits and agreements might include, but are not limited to:

- City, county, or local agency use permits.
- Sensitive area ordinance permits.

**610.04(15)(b) PS&E Development**

Subsurface exploration (drilling) is performed and a geotechnical foundation report is prepared to provide all necessary geotechnical recommendations needed to complete the PS&E.

The designer requests a geotechnical report from the HQ Geotechnical Office or the RME, as appropriate. The site data given in [610.04\(4\)](#), as applicable, is provided along with the following information:

- A plan showing final structure locations as well as existing structures.
- Proposed structure loadings.

WSF can expect to receive the following:

- Results of any borings or laboratory tests conducted.
- A description of geotechnical site conditions.
- Final foundation types, depths, and capacities.
- Final wall types and geotechnical designs/parameters for each wall.
- Assessment of constructibility issues to be considered in foundation selection and when assembling the PS&E.
- Pile driving information: driving resistance and estimated overdrive.
- Surfacing depths and/or pavement repair and drainage schemes.

WSF uses this information to complete the PS&E.

Upon receipt of the WSF PS&E review set, the HQ Geotechnical Office provides WSF with a Summary of Geotechnical Conditions for inclusion in Appendix B of the Contract. A Final Geotechnical Project Documentation package is assembled by the HQ Geotechnical Office and sent to WSF or the Plans Branch, as appropriate, for reproduction and sale to prospective bidders.

### 610.05 Use of Geotechnical Consultants

Prior to authorizing a consultant to conduct the geotechnical investigation for a project, the region Project Office, the HQ Geotechnical Office, and the RME determine the scope of work and schedule for the project and whether or not the project will go to a geotechnical consultant.

Once the decision has been made to have a consultant conduct the geotechnical investigation for a project, the HQ Geotechnical Office or the RME assists in developing the geotechnical scope and estimate for the project (WSDOT Consultant Services assists in this process). A team meeting between the consultant team, the region or Washington State Ferries (depending on whose project it is), and the HQ Geotechnical Office/RME is conducted early in the project to develop technical communication lines and relationships. Good proactive communication between all members of the project team is crucial to the success of the project due to the complex supplier-client relationships.

Additional guidelines on the use of geotechnical consultants and the development of a scope of work for the consultant are provided in the *Geotechnical Design Manual*.

### 610.06 Geotechnical Work by Others

Geotechnical design work conducted for the design of structures, or other engineering works by other agencies or private developers within the right of way, is subject to the same geotechnical engineering requirements as for engineering works performed by WSDOT. Therefore, the provisions contained within this chapter also apply in principle to such work. All geotechnical work conducted for engineering works within the WSDOT right of way or that otherwise directly impacts WSDOT facilities must be reviewed and approved by the HQ Geotechnical Office or the RME, depending on the nature of the work.

Additional requirements for geotechnical work by others that impacts WSDOT facilities and land within the WSDOT right of way are set forth in the *Geotechnical Design Manual*.

### 610.07 Surfacing Report

Detailed criteria and methods that govern pavement rehabilitation can be found in the *WSDOT Pavement Policy*. The RME provides the surfacing report to the region Project Office. This report provides recommended pavement types, surfacing depths, pavement drainage recommendations, and pavement repair recommendations.



## 610.08 Documentation

### 610.08(1) Design Documentation

Refer to [Chapter 300](#) for design documentation requirements.

### 610.08(2) Final Geotechnical Project Documentation and Geotechnical Information for the Construction Contract

Once a project PS&E is near completion, all of the geotechnical design memorandums and reports are compiled together to form the Final Geotechnical Project Documentation, to be published for the use of prospective bidders. The detailed process for this is located in the [Plans Preparation Manual](#).

Geotechnical information included in the contract consists of the final project boring logs and, as appropriate for the project, a Summary of Geotechnical Conditions. The boring logs from the geotechnical reports are incorporated into the contract by the region, WSF, or Urban Corridors Office (UCO) staff. The Summary of Geotechnical Conditions is provided to the region, WSF, or UCO by the HQ Geotechnical Office and/or RME.

Additional geotechnical project documentation requirements are set forth in the [Geotechnical Design Manual](#).

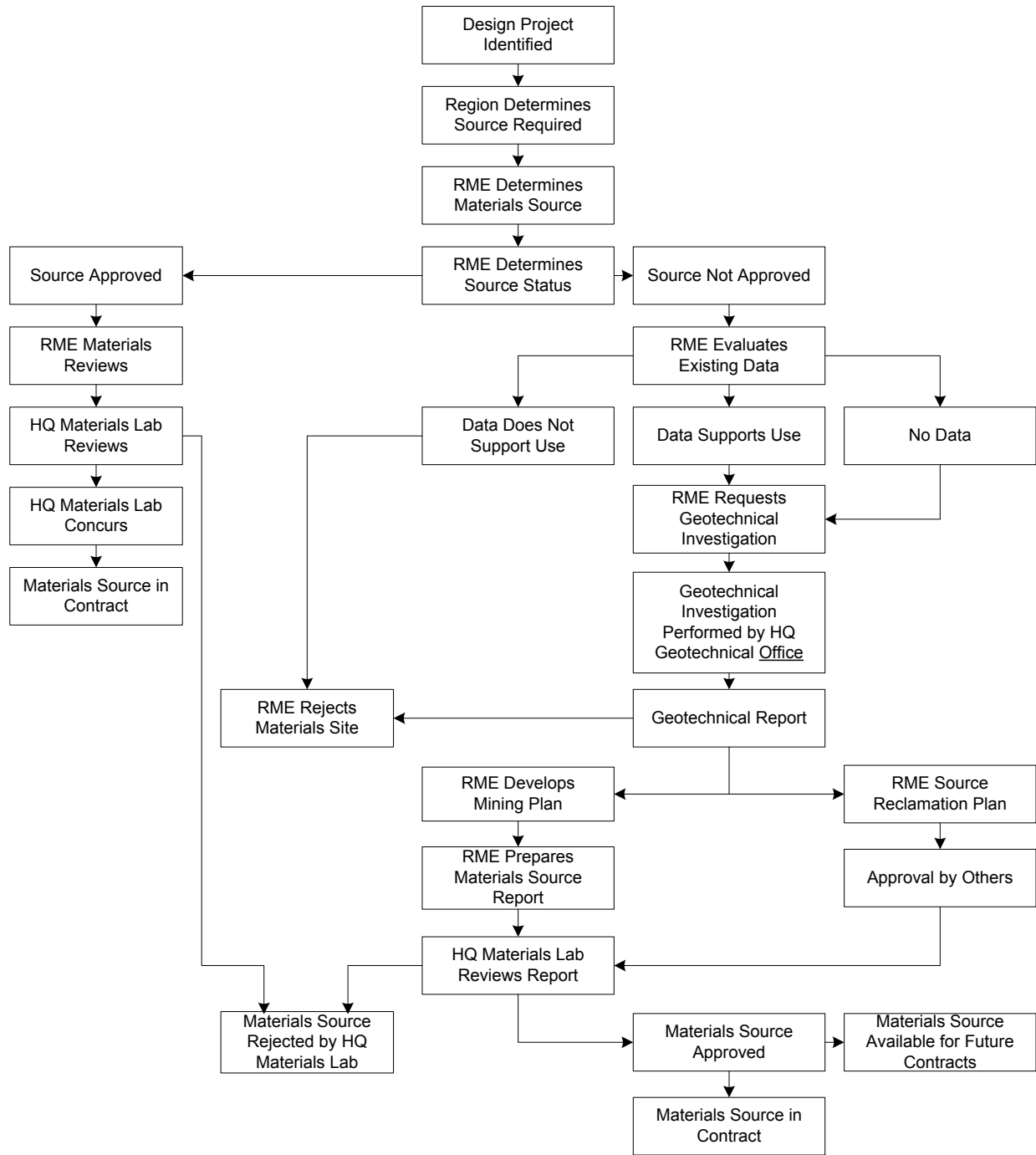

**Materials Source Development**  
*Exhibit 610-1*

620.01 General

620.02 Estimating Tables

### 620.01 General

Detailed criteria and methods that govern pavement design are in the Washington State Department of Transportation (WSDOT) *Pavement Policy*, which is available from the Pavements website:

[www.wsdot.wa.gov/business/materialslab/pavements/default.htm](http://www.wsdot.wa.gov/business/materialslab/pavements/default.htm)

The pavement design for all Design-Build project RFPs will be conducted by the State Materials Lab, Pavement Division.

### 620.02 Estimating Tables

Exhibits 620-1 through 620-5h are to be used when detailed estimates are required. They are for pavement sections, shoulder sections, stockpiles, and asphalt distribution. Prime coats and fog seal are in Exhibit 620-2a.

Type of Material	Unit Dry Weight			
	Truck Measure		Compacted on Roadway	
	lb/cy	T/cy	lb/cy	T/cy
Ballast	3,100	1.55	3,900	1.95
Crushed Surfacing Top Course	2,850	1.43	3,700	1.85
Crushed Surfacing Base Course	2,950	1.48	3,700	1.85
Screened Gravel Surfacing			3,700	1.85
**Gravel Base			3,400 – 3,800	1.70 – 1.90
Permeable Ballast			2,800	1.40
Maintenance Sand 3/8" – 0	2,900	1.45		
Mineral Aggregate 2" – 1"	2,600	1.30		
Mineral Aggregate 1 3/4" – 3/4"	2,600	1.30		
Mineral Aggregate 1 1/2" – 3/4"	2,550	1.28		
Mineral Aggregate 1" – 3/4"	2,500	1.25		
Mineral Aggregate 3/4" – 1/2"	2,400	1.20		
Mineral Aggregate 1 1/4" – 1/4"	2,600	1.30		
Mineral Aggregate 1" – 1/4"	2,600	1.30		
Mineral Aggregate 7/8" – 1/4"	2,550	1.28		
Mineral Aggregate 3/4" – 1/4"	2,500	1.25		
Mineral Aggregate 5/8" – 1/4"	2,650	1.33		
Mineral Aggregate 1/2" – 1/4" or #4	2,600	1.30		
Mineral Aggregate 1/4" or #4 – 0	2,900	1.45		
Concrete Aggr. No. 2 (1 1/4" - #4)	3,000	1.50		
Concrete Sand (Fine Aggregate)	2,900	1.45		
Crushed Cover Stone	2,850	1.43		
** 3,700 lb/cy (1.85 tons/cy) is recommended as the most suitable factor; however, if the grading approaches the coarseness of ballast, the factor would approach 3,800 lb/cy (1.90 tons/cy), and if the grading contains more than 45% sand, the factor would decrease, approaching 3,400 lb/cy (1.70 tons/cy) for material that is essentially all sand.				

**Notes:**

- Weights shown are dry weights and corrections are required for water contents.
- The tabulated weights for the materials are reasonably close; however, apply corrections in the following order:

For specific gravity:  $Wt. = \frac{\text{tabular wt.} \times \text{specific gravity on surface report}}{2.65}$

For water content:  $Wt. = \text{tabular wt.} \times (1 + \text{free water \% in decimals})$

- If material is to be stockpiled, increase required quantities by 10% to allow for waste.
- Direct attention to the inclusion of crushed surfacing top course material that may be required for keystone when estimating quantities for projects having ballast course.

**Estimating: Miscellaneous Tables**

*Exhibit 620-1*

630.01	General
630.02	References
630.03	Geosynthetic Types and Characteristics
630.04	Geosynthetic Function Definitions and Applications
630.05	Design Approach for Geosynthetics
630.06	Design Responsibility
630.07	Documentation

### 630.01 General

Geosynthetics include a variety of manufactured products that are used by the Washington State Department of Transportation (WSDOT) in drainage, earthwork, erosion control, and soil reinforcement applications.

The following geosynthetic applications are addressed in the *Standard Specifications for Road, Bridge, and Municipal Construction* (*Standard Specifications*):

- Low survivability underground drainage
- Moderate survivability underground drainage
- Separation
- Soil stabilization
- Moderate survivability permanent erosion control
- High survivability permanent erosion control
- Ditch lining
- Temporary silt fence

The *Standard Specifications* addresses geosynthetic properties as well as installation requirements and are not site-specific. The geosynthetic properties provided are based on the range of soil conditions likely to be encountered in Washington for the applications defined. Other applications, such as prefabricated edge drains, pond liners, and geotextile retaining walls, are currently handled by special provision.

Design responsibilities are discussed in 630.05 and illustrated in Exhibits 630-4 and 630-5.

This chapter does not address applications where geosynthetics are used to help establish vegetation through temporary prevention of erosion (vegetation mats).

### 630.02 References

#### (1) Design Guidance

*Highway Runoff Manual*, M 31-15, WSDOT

*Hydraulics Manual*, M 23-03, WSDOT

*Plans Preparation Manual*, M 22-31, WSDOT

*Standard Specifications for Road, Bridge, and Municipal Construction* (*Standard Specifications*), M 41-10, WSDOT

WSDOT *Pavement Policy*, available at the Pavements website:

[www.wsdot.wa.gov/business/materialslab/pavements/default.htm](http://www.wsdot.wa.gov/business/materialslab/pavements/default.htm)

### 630.03 Geosynthetic Types and Characteristics

Geosynthetics include woven and nonwoven geotextiles, geogrids, geonets, geomembranes, and geocomposites. (Examples of the various types of geosynthetics are provided in [Exhibit 630-6](#).) Terms used in the past for these construction materials include *fabrics*, *filter fabric*, or *filter cloth*, which are for the most part synonymous with the newer term *geotextile*.

#### (1) Definitions

Definitions of the geosynthetic types are as follows:

##### (a) Woven Geotextiles

Slit polymer tapes, monofilament fibers, fibrillated yarns, or multifilament yarns simply woven into a mat. Woven geotextiles generally have relatively high strength and stiffness and, except for the monofilament wovens, relatively poor drainage characteristics.

##### (b) Nonwoven Geotextiles

A sheet of continuous or staple fibers entangled randomly into a felt for needle-punched nonwovens and pressed and melted together at the fiber contact points for heat-bonded nonwovens. Nonwoven geotextiles tend to have low-to-medium strength and stiffness with high elongation at failure and relatively good drainage characteristics. The high elongation characteristic gives them superior ability to deform around stones and sticks.

##### (c) Geogrids

A polymer grid mat constructed either of coated yarns or a punched and stretched polymer sheet. Geogrids usually have high strength and stiffness and are used primarily for soil reinforcement.

##### (d) Geonets

Similar to geogrids, but typically lighter weight and weaker, with smaller mesh openings. Geonets are used in light reinforcement applications or are combined with drainage geotextiles to form a drainage structure.

##### (e) Geomembranes

Impervious polymer sheets that are typically used to line ponds or landfills. In some cases, geomembranes are placed over moisture-sensitive swelling clays to control moisture.

##### (f) Geocomposites

Prefabricated edge drains, wall drains, and sheet drains that typically consist of a cusped or dimpled polyethylene drainage core wrapped in a geotextile. The geotextile wrap keeps the core clean so that water can freely flow through the drainage core, which acts as a conduit. Prefabricated edge drains are used in place of shallow geotextile-wrapped trench drains at the edges of the roadway to provide subgrade and base drainage. Wall drains and sheet drains are typically placed between the back of the wall and the soil to drain the soil retained by the wall.

- Soil in the vicinity of the proposed geotextile location that consists of alternate thin layers of silt or clay with potentially water-bearing sand layers on the order of 1 to 3 inches thick or less.
- Soil known through past experience to be problematic for geosynthetic drains.
- Drains in native soil behind structures except drains contained within granular backfill.
- Drains designed to stabilize unstable slopes.
- Drains designed to mitigate frost heave.

In such cases, obtain assistance from the HQ Materials Laboratory, Geotechnical Office. To initiate the special design, provide a plan and cross section showing:

- The geosynthetic structure to be designed.
- The structure's relative location to other adjacent structures that it could potentially affect.
- The structure's intended purpose.
- Any soil data in the vicinity.

Consider a site-specific design for temporary silt fences:

- If silt fence must be used in intermittent streams or where a significant portion of the silt fence functions as a barrier that directs flow to the lower portions of the silt fence.
- If the fence must be located on steep slopes.
- In situations not meeting the requirements in Exhibits 630-2 and 630-3.
- If the 2-year, 24-hour design storm for the site is greater than the 3 inches assumed for the development of Exhibits 630-2 and 630-3.
- Where concentrated flow is anticipated.
- If closer than 7 feet from an environmentally sensitive area.
- If more than 2 feet of storage depth is needed.

For a site-specific temporary silt fence design, obtain assistance from the HQ Hydraulics Section. To initiate the design, send the following information to the HQ Hydraulics Section and a copy to the HQ Materials Laboratory, Geotechnical Office:

- Plan sheets showing proposed silt fence locations and grading contours.
- Estimate of the area contributing runoff to each silt fence, including percentage and general type of vegetative cover within the contributing area.
- Any available site soil information.

For all site-specific designs of applications not covered by the *Standard Specifications*, complete plans and special provisions are needed. In general, for site-specific designs of *Standard Specifications* applications, only a minor modification of the appropriate geotextile property table will be needed.

### 630.06 Design Responsibility

The design responsibility and process for geotextile design are illustrated in Exhibits 630-4 and 630-5. The region Project Development Office, in particular the region Project Manager, is responsible to initiate and develop all geotextile designs for the *Standard Specifications*, except for roadway separation and soil stabilization applications, which are initiated and developed by the region Materials Laboratory.

The region Materials Laboratory assists the region Project Manager with *Standard Specifications* underground drainage and permanent erosion control designs.

The region Environmental Design Office assists with *Standard Specifications*, permanent erosion control, and temporary silt fence designs.

Once the region Project Manager or Materials Laboratory has determined that a geotextile is appropriate, development of a geotextile design for the *Standard Specifications* includes the development of plan details showing the plan location and cross section of the geotextile installation. Standard details for geotextiles as provided in the *Plans Preparation Manual* may be used or modified to adapt to the specific project situation. Note that only minimum dimensions for drains are provided in these standard details.

Site-specific geosynthetic designs and applications not addressed by the *Standard Specifications* are designed by the region with the assistance of the HQ Materials Laboratory, Geotechnical Office, or the HQ Hydraulics Section as described in 630.05.

Design assistance by the HQ Geotechnical Office or HQ Hydraulics Section for site-specific design of *Standard Specifications* applications includes determination of geosynthetic properties and other advice as needed to complete the geosynthetic plans and any special provisions required.

The HQ Geotechnical Office is fully responsible to develop and complete the following:

- Geosynthetic design, plan details that can be used to develop the contract plan sheets, and special provisions for geosynthetic reinforced walls, slopes, and embankments.
- Deep trench drains for landslide stabilization.
- Other applications that are an integral part of a Headquarters geotechnical design.

The region Project Manager incorporates the plan details and special provisions into the PS&E.

### 630.07 Documentation

Refer to [Chapter 300](#) for design documentation requirements.



- 710.01 [General](#)
- 710.02 [References](#)
- 710.03 [Required Data for All Structures](#)
- 710.04 [Additional Data for Waterway Crossings](#)
- 710.05 [Additional Data for Grade Separations](#)
- 710.06 [Additional Data for Widening](#)
- 710.07 [Documentation](#)

### 710.01 General

The Washington State Department of Transportation (WSDOT) Headquarters (HQ) Bridge and Structures Office provides structural design services to the regions. This chapter describes the information required by the HQ Bridge and Structures Office to perform this function.

### 710.02 References

- [Bridge Design Manual](#), M 23-50, WSDOT
- [Plans Preparation Manual](#), M 22-31, WSDOT

### 710.03 Required Data for All Structures

Bridge site data provides information about the type of crossing, topography, type of structure, and potential future construction. Submit bridge site data to the HQ Bridge and Structures Office. Provide a cover memo that gives general information on the project, describes the attachments, and transmits the forms and data included in the submittal. Submit site data as a CAD file, supplemental drawings, and a report. (See [Exhibit 710-2](#) for items to include in a bridge site data submittal). Direct any questions relating to the preparation of bridge site data to the HQ Bridge and Structures Office. The [Bridge Design Manual](#) shows examples of required WSDOT forms.

#### (1) Scour

At any location where a structure can be in contact with water (such as culvert outfall, lake, river, or floodplain), there is a risk of scour. This risk must be analyzed. Contact the HQ Geotechnical Office and the HQ Hydraulics Office to determine whether a scour analysis is required.

#### (2) CAD Files and Supplemental Drawings

The HQ Bridge and Structures Office uses the microGDS Computer-Aided Drafting (CAD) system. CAD files prepared for use as bridge site data will be accepted in standard DGN, DXF, or DWG format.

Prepare plan, profile, and section drawings for all structures. Include copies of the CAD site data and supplemental drawings in the reduced plan sheet format with the submittal.

Use a complete and separate CAD file for each structure. (See the *Plans Preparation Manual* for information regarding drawing levels and use of the Bridge and Structures format.) The *Bridge Design Manual* contains examples of completed bridge preliminary plans. These plans show examples of the line styles and drawing format for site data in CAD.

Bridge site data is used to prepare the bridge layout plan, which is to be used in the contract plans. Include the following information in the CAD files or in the supplemental drawings:

(a) **Plan**

- The drawing scales shown are for the full-sized contract plan format and are a guide only. Consider the width and general alignment of the structure when selecting the scale. For structures on curved alignments or where the bridge width is nearly equal to or greater than the bridge length, consult the HQ Bridge and Structures Office for an appropriate plan scale.

Length of Structure	Scale
20 ft to 100 ft	1"=10'
100 ft to 500 ft	1"=20'
500 ft to 800 ft	1"=30'
800 ft to 1,100 ft	1"=40'
More than 1,100 ft	1"=50'

**Bridge Site Plan Scales**

*Exhibit 710-1*

- Vertical and horizontal datum control (see [Chapters 400](#) and [410](#)).
- Contours of the existing ground surface. Use intervals of 1, 2, 5, or 10 feet, depending on terrain and plan scale. The typical contour interval is 2 feet. Use 1-foot intervals for flat terrain. Use 5-foot or 10-foot intervals for steep terrain or small scales. Show contours beneath an existing or proposed structure and beneath the water surface of any waterway.
- Alignment of the proposed highway and traffic channelization in the vicinity.
- Location by section, township, and range.
- Type, size, and location of all existing or proposed sewers, telephone and power lines, water lines, gas lines, traffic barriers, culverts, bridges, buildings, and walls.
- Location of right of way lines and easement lines.
- Distance and direction to nearest towns or interchanges along the main alignment in each direction.
- Location of all roads, streets, and detours.
- Stage construction plan and alignment.
- Type, size, and location of all existing and proposed sign structures, light standards, and associated conduits and junction boxes. Provide proposed signing and lighting items when the information becomes available.
- Location of existing and proposed drainage.
- Horizontal curve data. Include coordinates for all control points.

**(b) Profile**

- Profile view showing the grade line of the proposed or existing alignment and the existing ground line along the alignment line.
- Vertical curve data.
- Superelevation transition diagram.

**(c) Section**

- Roadway sections on the bridge and at bridge approaches. Indicate the lane and shoulder widths, cross slopes and side slopes, ditch dimensions, and traffic barrier requirements.
- Stage construction roadway geometrics with the minimum lane and roadway widths specified.

**(3) Report**

Submit DOT Form 235-002, Bridge Site Data-General. Supplement the CAD drawings with the following items:

- Vicinity maps
- Class of highway
- Design speed
- Special requirements for replacing or relocating utility facilities
- ADT and DHV counts
- Truck traffic percentage
- Requirements for road or street maintenance during construction

**(4) Video and Photographs**

Submit a video of the site. Show all the general features of the site and details of existing structures. Scan the area slowly, spending extra time showing existing bridge pier details and end slopes. A “voice over” narrative on the video is necessary for orientation.

Color photographs of the structure site are desirable. Include detailed photographs of existing abutments, piers, end slopes, and other pertinent details for widenings, bridge replacements, or sites with existing structures.

**710.04 Additional Data for Waterway Crossings**

Coordinate with the HQ Hydraulics Section and supplement the bridge site data for all waterway crossings with the DOT Form 235-001, Bridge Site Data for Stream Crossings, and the following:

- Show riprap or other slope protection requirements at the bridge site (type, plan limits, and cross section) as determined by the HQ Hydraulics Section.
- Show a profile of the waterway. The extent will be determined by the HQ Hydraulics Section.
- Show cross sections of the waterway. The extent will be determined by the HQ Hydraulics Section.

The requirements for waterway profile and cross sections may be less stringent if the HQ Hydraulics Section has sufficient documentation (FEMA reports, for example) to make a determination. Contact the HQ Hydraulics Section to verify the extent of the information needed. Coordinate any rechannelization of the waterway with the HQ Hydraulics Section. Many waterway crossings require a permit from the U.S. Coast Guard (see [Chapter 225](#) and the [Environmental Procedures Manual](#)). Generally, ocean tide-influenced waterways and waterways used for commercial navigation require a Coast Guard permit. These structures require the following additional information:

- Names and addresses of the landowners adjacent to the bridge site.
- Quantity of new embankment material within the floodway. This quantity denotes, in cubic yards, the material below and the material above normal high water.

Some waterways may qualify for an exemption from Coast Guard permit requirements if certain conditions are met (see the [Bridge Design Manual](#)). If the waterway crossing appears to satisfy these conditions, then submit a statement explaining why this project is exempt from a Coast Guard permit. Attach this exemption statement to the Environmental Classification Summary prepared for the project and submit it to the HQ Design Office for processing to the Federal Highway Administration (FHWA).

The region is responsible for coordination with the HQ Bridge and Structures Office, U.S. Army Corps of Engineers, and U.S. Coast Guard for waterways that may qualify for a permit exemption. The HQ Bridge and Structures Office is responsible for coordination with the U.S. Coast Guard for waterways that require a permit.

## 710.05 Additional Data for Grade Separations

### (1) Highway-Railroad Separation

Supplement bridge site data for structures involving railroads with the following:

#### (a) Plan

- Alignment of all existing and proposed railroad tracks.
- Center-to-center spacing of all tracks.
- Angle, station, and coordinates of all intersections between the highway alignment and each track.
- Location of railroad right of way lines.
- Horizontal curve data. Include coordinates for all circular and spiral curve control points.

#### (b) Profile

- For proposed railroad tracks: profile, vertical curve, and superelevation data for each track.
- For existing railroad tracks: elevations accurate to 0.1 foot taken at 10-foot intervals along the top of the highest rail of each track. Provide elevations to 50 feet beyond the extreme outside limits of the existing or proposed structure. Tabulate elevations in a format acceptable to the HQ Bridge and Structures Office.

### (c) Minimum Clearance for Existing Structures

The criteria used to evaluate the vertical clearance for existing structures depend on the work being done on or under that structure. When evaluating an existing structure on the Interstate System, see [720.04\(5\)\(e\)](#), Coordination. This guidance applies to bridge clearances over state highways and under state highways at interchanges. For state highways over local roads and streets, city or county vertical clearance requirements may be used as minimum design criteria. (See [Exhibit 720-1](#) for bridge vertical clearances.)

#### 1. Bridge Over a Roadway

For a project that will widen an existing structure over a highway or where the highway will be widened under an existing structure, the vertical clearance can be as little as 16.0 feet on the Interstate System or other freeways or 15.5 feet on nonfreeway routes. An approved deviation is required for clearance less than 16.0 feet on Interstate routes or other freeways and 15.5 feet on nonfreeway routes.

For a planned resurfacing of the highway under an existing bridge, if the clearance will be less than 16.0 feet on the Interstate System or other freeways and 15.5 feet on nonfreeway routes, evaluate the following options and include in a deviation request:

- Pavement removal and replacement.
- Roadway excavation and reconstruction to lower the roadway profile.
- Providing a new bridge with the required vertical clearance.

Reducing roadway paving and surfacing thickness under the bridge to achieve the minimum vertical clearance can cause accelerated deterioration of the highway and is not recommended. Elimination of the planned resurfacing in the immediate area of the bridge might be a short-term solution if recommended by the Region Materials Engineer (RME). Solutions that include milling the existing surface followed by overlay or inlay must be approved by the RME to ensure adequate pavement structure is provided.

For other projects that include an existing bridge where no widening is proposed on or under the bridge, and the project does not affect vertical clearance, the clearance can be as little as 14.5 feet. For these projects, document the clearance in the Design Documentation Package. For an existing bridge with less than a 14.5-foot vertical clearance, an approved deviation request is required.

#### 2. Bridge Over a Railroad Track

For an existing structure over a railroad track, the vertical clearance can be as little as 22.5 feet. A lesser clearance can be used with the agreement of the railroad company and the approval of the Washington State Utilities and Transportation Commission. Coordinate railroad clearance issues with the HQ Design Office Railroad Liaison.

**(d) Signing**

Low-clearance warning signs are necessary when the vertical clearance of an existing bridge is less than 15 feet 3 inches. Refer to the *Manual on Uniform Traffic Control Devices* and the *Traffic Manual* for other requirements for low-clearance signing.

**(e) Coordination**

The Interstate System is used by the Department of Defense (DOD) for the conveyance of military traffic. The Military Traffic Management Command Transportation Engineering Agency (MTMCTEA) represents the DOD in public highway matters. The MTMCTEA has an inventory of vertical clearance deficiencies over the Interstate System in Washington State. Contact the MTMCTEA, through the Federal Highway Administration (FHWA), if either of the following changes is proposed to these bridges:

- A project would create a new deficiency of less than a 16.0-foot vertical clearance over an Interstate highway.
- The vertical clearance over the Interstate is already deficient (less than 16.0 feet) and a change (increase or decrease) to vertical clearance is proposed.

Coordination with MTMCTEA is required for these changes on all rural Interstate highways and for one Interstate route through each urban area.

**(6) Liquefaction Impact Considerations**

To determine the amount of settlement and the potential for the soil to flow laterally during the design level earthquake due to liquefaction, an analysis performed by the HQ Geotechnical Office is needed for each bridge project site location. The information collected is used by bridge engineers to determine the bridge's capability to withstand the movement and loading in a seismic event and to explore other foundation mitigation options not necessitating total bridge replacement.

The HQ Bridge and Structures Office, in collaboration with the HQ Geotechnical Office, evaluates bridge-widening projects involving liquefiable soils and recommends appropriate liquefaction mitigation. The following guidance is intended to assist designers in making project decisions that balance project risks with project and program budget realities.

**(a) Design Decision Considerations**

The following design decision guidance is generally in order of the complexity of project decision making, starting with the most straightforward through the most complex.

1. New bridges will be designed to current seismic and liquefaction standards.
2. Bridge widening that does not require new substructure (a new column) does not require consideration of liquefaction mitigation.
3. Widening that involves any new substructure will require a settlement and lateral loading analysis by the HQ Bridge and Structures Office in collaboration with the HQ Geotechnical Office. Each analysis will be unique to the conditions at that particular bridge site.

- a. If a bridge has less than 15 years of its service life remaining, no liquefaction mitigation is necessary according to FHWA guidelines.
- b. If the HQ Geotechnical Office analysis demonstrates that the differential settlement induced by liquefaction between the existing bridge and the widened portion will not create forces great enough to cause collapse of the existing bridge, and if lateral loading and movement caused by the liquefaction is minimal, liquefaction mitigation may not be necessary. The decision must be endorsed by the State Geotechnical Engineer, the State Bridge Engineer and the Regional Administrator. The decision and rationale are to be included in the Design Documentation Package.
- c. If the HQ Geotechnical Office analysis demonstrates that the differential settlement induced by liquefaction or the lateral loading and movement will be substantial and these movements will result in the collapse of the existing and widened portion of the bridge, additional analysis and documentation are necessary for the project to proceed. A preliminary design and estimate of the mitigation necessary to prevent collapse needs to be performed. Consider alternative designs that eliminate or reduce the need for the widening.

#### **(b) Deferring Liquefaction Mitigation**

##### **1. Consideration of Deferment**

If an alternative design concept is not feasible given the constraints of the project or program, consideration may be given to defer the liquefaction mitigation. Project-related structural retrofits that are deferred because of scope-related issues are to be considered for implementation through the WSDOT seismic retrofit program. The operating characteristics of the roadway and overall estimated cost of the liquefaction mitigation is typically considered in making that decision.

##### **2. Deferment Requires Approval**

A decision to defer the mitigation to the seismic retrofit program is made by the WSDOT Chief Engineer after reviewing and considering the alternatives. The decision is to be included in the Design Documentation Package (DDP). A memo from the Chief Engineer will be provided to the structural designer of record documenting the agency's decision to defer the mitigation work to the WSDOT seismic retrofit program. A copy of the memo is to be included in the DDP and the contract general notes.

#### **(7) Pedestrian and Bicycle Facilities**

When pedestrians or bicyclists are anticipated on bridges, provide facilities consistent with guidance in Chapters 1510, 1515, and 1520. For instances where pedestrian users are not anticipated, evaluate the potential for stranded motorists to become pedestrians, where they may have exited their vehicle after a breakdown or other emergency. The infrequent and random nature of these occurrences makes it difficult to identify locations with even a moderate probability of pedestrian exposure.

Evolving programs and technologies such as incident response, personal cell phones, and ITS cameras have further reduced the probability of motorists becoming pedestrians. Investigate other methods of treatment such as pedestrian scale signing or other low-cost safety improvement measures. Document decisions in the DDP.

### **(8) Bridge Approach Slab**

Bridge approach slabs are reinforced concrete pavement installed across the full width of the bridge ends. They provide a stable transition from normal roadway cross section to the bridge ends, and they compensate for differential expansion and contraction of the bridge and the roadway.

Bridge approach slabs are provided on all new bridges. If an existing bridge is being widened and it has an approach slab, slabs are required on the widenings. The region, with the concurrence of the State Geotechnical Engineer and the State Bridge Engineer, may decide to omit bridge approach slabs.

### **(9) Traffic Barrier End Treatment**

Plans for new bridge construction and bridge traffic barrier modifications include provisions for the connection of bridge traffic barriers to the longitudinal barrier approaching and departing the bridge. Indicate the preferred longitudinal barrier type and connection during the review of the bridge preliminary plan.

### **(10) Bridge End Embankments**

The design of embankment slopes at bridge ends depends on several factors. The width of the embankment is determined not only by the width of the roadway, but also by the presence of traffic barriers, curbs, and sidewalks, all of which create the need for additional widening. Examples of the additional widening required for these conditions are shown in the [Standard Plans](#).

The end slope is determined by combining the recommendations of several technical experts within WSDOT. [Exhibit 720-3](#) illustrates the factors taken into consideration and the experts involved in the process.

### **(11) Bridge Slope Protection**

Slope protection provides a protective and aesthetic surface for exposed slopes under bridges. Slope protection is normally provided under:

- Structures over state highways.
- Structures within an interchange.
- Structures over other public roads unless requested otherwise by the public agency.
- Railroad overcrossings if requested by the railroad.

Slope protection is usually not provided under pedestrian structures.

The type of slope protection is selected at the bridge preliminary plan stage. Typical slope protection types are concrete slope protection, semi-open concrete masonry, and rubble stone.



Rockeries (rock walls) behave to some extent like gravity walls. However, the primary function of a rockery is to prevent erosion of an oversteepened but technically stable slope. Rockeries consist of large, well-fitted rocks stacked on top of one another to form a wall.

An example of a rockery and reinforced slope is provided in [Exhibit 730-10](#).

## 730.02 References

### (1) Federal/State Laws and Codes

[Washington Administrative Code \(WAC\) 296-155](#), Safety standards for construction work

### (2) Design Guidance

[Bridge Design Manual](#), M 23-50, WSDOT

[Standard Plans for Road, Bridge, and Municipal Construction \(Standard Plans\)](#), M 21-01, WSDOT

[Plans Preparation Manual](#), M 22-31, WSDOT

[Roadside Manual](#), M 25-30, WSDOT

## 730.03 Design Principles

The design of a retaining wall or reinforced slope consists of the following principal activities:

- Develop wall/slope geometry
- Provide adequate subsurface investigation
- Evaluate loads and pressures that will act on the structure
- Design the structure to withstand the loads and pressures
- Design the structure to meet aesthetic requirements
- Ensure wall/slope constructibility
- Coordinate with other design elements

The structure and adjacent soil mass also needs to be stable as a system, and the anticipated wall settlement needs to be within acceptable limits.

## 730.04 Design Requirements

### (1) Wall/Slope Geometry

Wall/slope geometry is developed considering the following:

- Geometry of the transportation facility itself
- Design Clear Zone requirements (see [Chapter 1600](#))
- Flare rate and approach slope when inside the Design Clear Zone (see [Chapter 1610](#))
- Right of way constraints
- Existing ground contours
- Existing and future utility locations
- Impact to adjacent structures
- Impact to environmentally sensitive areas

For wall/slope geometry, also consider the foundation embedment and type anticipated, which requires coordination between the various design groups involved.

Retaining walls are designed to limit the potential for snagging vehicles by removing protruding objects (such as bridge columns, light fixtures, or sign supports).

Provide a traffic barrier shape at the base of a new retaining wall constructed 12 feet or less from the edge of the nearest traffic lane. The traffic barrier shape is optional at the base of the new portion when an existing vertical-faced wall is being extended (or the existing wall may be retrofitted for continuity). Depending on the application, precast or cast-in-place Single Slope Concrete Barrier with vertical back or Type 4 Concrete Barrier may be used for both new and existing walls except when the barrier face can be cast as an integral part of a new wall. Deviations may be considered, but they require approval as prescribed in [Chapter 300](#). For deviations from the above, deviation approval is not required where sidewalk exists in front of the wall or in other situations where the wall face is otherwise inaccessible to traffic.

## **(2) Investigation of Soils**

All retaining wall and reinforced slope structures require an investigation of the underlying soil/rock that supports the structure. [Chapter 610](#) provides guidance on how to complete this investigation. A soil investigation is an integral part of the design of any retaining wall or reinforced slope. The stability of the underlying soils, their potential to settle under the imposed loads, the usability of any existing excavated soils for wall/reinforced slope backfill, and the location of the groundwater table are determined through the geotechnical investigation.

## **(3) Geotechnical and Structural Design**

The structural elements of the wall or slope and the soil below, behind, and/or within the structure are designed together as a system. The wall/slope system is designed for overall external stability as well as internal stability. Overall external stability includes stability of the slope the wall/reinforced slope is a part of and the local external stability (overturning, sliding, and bearing capacity). Internal stability includes resistance of the structural members to load and, in the case of MSE walls and reinforced slopes, pullout capacity of the structural members or soil reinforcement from the soil.

### **(a) Scour**

At any location where a retaining wall or reinforced slope can be in contact with water (such as a culvert outfall, ditch, wetland, lake, river, or floodplain), there is a risk of scour at the toe. This risk must be analyzed. Contact the HQ Geotechnical Office and HQ Hydraulics Office to determine whether a scour analysis is required.

## **(4) Drainage Design**

One of the principal causes of retaining wall/slope failure is the additional hydrostatic load imposed by an increase in the water content in the material behind the wall or slope. This condition results in a substantial increase in the lateral loads behind the wall/slope since the material undergoes a possible increase in unit weight, water pressure is exerted on the back of the wall, and the soil shear strength undergoes a possible reduction. To alleviate this, adequate drainage for the retaining wall/slope

needs to be considered in the design stage and reviewed by the region Materials Engineer during construction. The drainage features shown in the *Standard Plans* are the minimum basic requirements. Underdrains behind the wall/slope need to daylight at some point in order to adequately perform their drainage function. Provide positive drainage at periodic intervals to prevent entrapment of water.

Native soil may be used for retaining wall and reinforced slope backfill if it meets the requirements for the particular wall/slope system. In general, use backfill that is free-draining and granular in nature. Exceptions to this can be made depending on the site conditions as determined by the Geotechnical Office of the Headquarters (HQ) Materials Laboratory.

A typical drainage detail for a gravity wall (in particular, an MSE wall) is shown in [Exhibit 730-11](#). Include drainage details with a wall unless otherwise recommended to be deleted by the Region Materials Engineer or HQ Geotechnical Office.

### **(5) Aesthetics**

Retaining walls and slopes can have a pleasing appearance that is compatible with the surrounding terrain and other structures in the vicinity. To the extent possible within functional requirements and cost-effectiveness criteria, this aesthetic goal is to be met for all visible retaining walls and reinforced slopes.

Aesthetic requirements include consideration of the wall face material, top profile, terminals, and surface finish (texture, color, and pattern). Where appropriate, provide planting areas and irrigation conduits. These will visually soften walls and blend them with adjacent areas. Avoid short sections of retaining wall or steep slope where possible.

In higher walls, variations in slope treatment are recommended for a pleasing appearance. High continuous walls are generally not desirable from an aesthetic standpoint, because they can be quite imposing. Consider stepping high or long retaining walls in areas of high visibility. Plantings may be considered between wall steps.

Approval by the State Bridge and Structures Architect is required on all retaining wall aesthetics, including finishes, materials, and configuration (see [Chapter 950](#)).

### **(6) Constructability**

Consider the potential effect that site constraints might have on the constructability of the specific wall/slope. Constraints to be considered include but are not limited to site geometry, access, time required to construct the wall, environmental issues, and impact on traffic flow and other construction activities.

### **(7) Coordination With Other Design Elements**

#### **(a) Other Design Elements**

Retaining wall and slope designs are to be coordinated with other elements of the project that might interfere with or impact the design or construction of the wall/slope. Also consider drainage features; utilities; luminaire or sign structures; adjacent retaining walls or bridges; concrete traffic barriers; and beam guardrails. Locate these design elements in a manner that will minimize the impacts to the wall elements. In general, locate obstructions within the wall backfill (such as

guardrail posts, drainage features, and minor structure foundations) a minimum of 3 feet from the back of the wall facing units.

Greater offset distances may be required depending on the size and nature of the interfering design element. If possible, locate these elements to miss reinforcement layers or other portions of the wall system. Conceptual details for accommodating concrete traffic barriers and beam guardrails are provided in [Exhibit 730-12](#).

Where impact to the wall elements is unavoidable, the wall system needs to be designed to accommodate these impacts. For example, it may be necessary to place drainage structures or guardrail posts in the reinforced backfill zone of MSE walls. This may require that holes be cut in the upper soil reinforcement layers or that discrete reinforcement strips be splayed around the obstruction. This causes additional load to be carried in the adjacent reinforcement layers due to the missing soil reinforcement or the distortion in the reinforcement layers.

The need for these other design elements and their impacts on the proposed wall systems are to be clearly indicated in the submitted wall site data so the walls can be properly designed. Contact the HQ Bridge and Structures Office (or the Geotechnical Office for geosynthetic walls/slopes and soil nail walls) for assistance regarding this issue.

**(b) Fall Protection**

Department of Labor and Industries regulations require that, when employees are exposed to the possibility of falling from a location 10 feet or more above the roadway (or other lower area), the employer is to ensure fall restraint or fall arrest systems are provided, installed, and implemented.

Design fall protection in accordance with [WAC 296-155-24510](#) for walls that create a potential for a fall of 10 feet or more. During construction or other temporary or emergency condition, fall protection will follow [WAC 296-155-505](#). Any need for maintenance of the wall's surface or the area at the top can expose employees to a possible fall. If the area at the top will be open to the public, see [Chapters 560](#), [Fencing](#), and [1510](#), [Pedestrian Design Considerations](#).

For maintenance of a tall wall's surface, consider harness tie-offs if other protective means are not provided.

For maintenance of the area at the top of a tall wall, a fall restraint system is required when all of the following conditions will exist:

- The wall is on a cut slope.
- A possible fall will be of 10 feet or more.
- Periodic maintenance will be performed on the area at the top.
- The area at the top is not open to the public.

Recommended fall restraint systems are:

- Wire rope railing with top and intermediate rails of ½-inch-diameter steel wire rope.
- Brown vinyl-coated chain link fencing.
- Steel pipe railing with 1½-inch nominal outside diameter pipe as posts and top and intermediate rails.
- Concrete as an extension of the height of the retaining wall.

usually increase the cost of any of these facing systems. Special wall terracing to provide locations for plants will also tend to increase costs. Therefore, weigh the costs against the value of the desired aesthetics.

Other factors that affect the costs of wall/slope systems include wall/slope size and length; access at the site and distance to the material supplier location; overall size of the project; and competition between wall suppliers. In general, costs tend to be higher for walls or slopes that are high, but short in length, due to lack of room for equipment to work. Sites that are remote or have difficult local access increase wall/slope costs. Small wall/slope quantities result in high unit costs. Lack of competition between materials or wall system suppliers can result in higher costs as well.

Some of the factors that increase costs are required parts of a project and are therefore unavoidable. Always consider such factors when estimating costs because a requirement may not affect all wall types in the same way. Current cost information can be obtained by consulting the *Bridge Design Manual* or by contacting the HQ Bridge and Structures Office.

### **(7) Summary**

For wall/slope selection, consider factors such as the intended application; the soil/rock conditions in terms of settlement, need for deep foundations, constructibility, and impacts to traffic; and the overall geometry in terms of wall/slope height and length, location of adjacent structures and utilities, aesthetics, and cost. Exhibits 730-1 through 730-6 provide a summary of many of the various wall/slope options available, including their advantages, disadvantages, and limitations. Note that specific wall types in the exhibits may represent multiple wall systems, some or all of which will be proprietary.

## **730.06 Design Responsibility and Process**

### **(1) General**

The retaining walls available for a given project include standard walls, nonstandard walls, and reinforced slopes.

Standard walls are those walls for which standard designs are provided in the Washington State Department of Transportation (WSDOT) *Standard Plans*. These designs are provided for reinforced concrete cantilever walls up to 35 feet in height. The internal stability design and the external stability design for overturning and sliding stability have already been completed for these standard walls. Determine overall slope stability and allowable soil bearing capacity (including settlement considerations) for each standard-design wall location.

Nonstandard walls may be either proprietary (patented or trademarked) or nonproprietary. Proprietary walls are designed by a wall manufacturer for internal and external stability, except bearing capacity, settlement, and overall slope stability, which are determined by WSDOT. Nonstandard nonproprietary walls are fully designed by WSDOT.

The geosynthetic soil reinforcement used in nonstandard nonproprietary geosynthetic walls is considered to be proprietary. It is likely that more than one manufacturer can supply proprietary materials for a nonstandard nonproprietary geosynthetic wall.

Reinforced slopes are similar to nonstandard nonproprietary walls in terms of their design process.

**(a) Preapproved Proprietary Walls**

Some proprietary wall systems are preapproved. Preapproved proprietary wall systems have been extensively reviewed by the HQ Bridge and Structures Office and the Geotechnical Office. Design procedures and wall details for preapproved walls have already been agreed upon between WSDOT and the proprietary wall manufacturers, allowing the manufacturers to competitively bid a particular project without having a detailed wall design provided in the contract plans.

Note that proprietary wall manufacturers might produce several retaining wall options, and not all options from a given manufacturer have necessarily been preapproved. For example, proprietary wall manufacturers often offer more than one facing alternative. It is possible that some facing alternatives are preapproved, whereas others are not preapproved. WSDOT does not preapprove the manufacturer, but specific wall systems by a given manufacturer can be preapproved.

It is imperative with preapproved systems that the design requirements for all preapproved wall alternatives for a given project be clearly stated so that the wall manufacturer can adapt the preapproved system to specific project conditions. For a given project, coordination of the design of all wall alternatives with all project elements that impact the wall is critical to avoid costly change orders or delays during construction. These elements include drainage features, utilities, luminaires and sign structures, noise walls, traffic barriers, guardrails, or other walls or bridges.

In general, standard walls are the easiest walls to incorporate into project Plans, Specifications, and Estimates (PS&E), but they may not be the most cost-effective option. Preapproved proprietary walls provide more options in terms of cost-effectiveness and aesthetics and are also relatively easy to incorporate into a PS&E. Nonstandard state-designed walls and nonpreapproved proprietary walls generally take more time and effort to incorporate into a PS&E because a complete wall design needs to be developed. Some nonstandard walls (such as state-designed geosynthetic walls) can be designed relatively quickly, require minimal plan preparation effort, and only involve the region and the Geotechnical Office. Other nonstandard walls such as soil nail and anchored wall systems require complex designs, involve both the HQ Bridge and Structures Office and Geotechnical Office, and require a significant number of plan sheets and considerable design effort.

The HQ Bridge and Structures Office maintains a list of the proprietary retaining walls that are preapproved. The region consults the HQ Bridge and Structures Office for the latest list. The region consults the HQ Geotechnical Office for the latest geosynthetic reinforcement list to determine which geosynthetic products are acceptable if a critical geosynthetic wall or reinforced slope application is anticipated.

**(b) Experimental Wall Systems**

Some proprietary retaining wall systems are classified as experimental by the Federal Highway Administration (FHWA). The HQ Bridge and Structures Office maintains a list of walls that are classified as experimental. If the wall intended

for use is classified as experimental, a work plan is to be prepared by WSDOT and approved by the FHWA.

An approved public interest finding, signed by the Director & State Design Engineer, Development Division, is required for the use of a sole source proprietary wall.

(c) **Gabion Walls**

Gabion walls are nonstandard walls that are to be designed for overturning, sliding, overall slope stability, settlement, and bearing capacity. A full design for gabion walls is not provided in the *Standard Plans*. Gabion baskets are typically 3 feet high by 3 feet wide, and it is typically safe to build gabions two baskets high (6 feet) but only one basket deep. This results in a wall base width of 50% of the wall height, provided soil conditions are reasonably good (medium-dense to dense granular soils are present below and behind the wall).

**(2) Responsibility and Process for Design**

A flow chart illustrating the process and responsibility for retaining wall/reinforced slope design is provided in [Exhibit 730-13a](#). As shown in the exhibit, the region initiates the process except for walls developed as part of a preliminary bridge plan. These are initiated by the HQ Bridge and Structures Office. In general, it is the responsibility of the design office initiating the design process to coordinate with other groups in the department to identify all wall/slope systems that are appropriate for the project in question. Coordinate with the region and the HQ Bridge and Structures Office, Geotechnical Office, and State Bridge and Structures Architect as early in the process as feasible.

Headquarters or region consultants, if used, are considered an extension of the Headquarters staff and must follow the process summarized in [Exhibit 730-13a](#). All consultant designs, from development of the scope of work to the final product, are to be reviewed and approved by the appropriate Headquarters offices.

(a) **Standard Walls**

The regions are responsible for detailing retaining walls for which standard designs are available.

For standard walls greater than 10 feet in height, and for all standard walls where soft or unstable soil is present beneath or behind the wall, a geotechnical investigation will be conducted, or reviewed and approved, by the HQ Geotechnical Office. Through this investigation, provide the foundation design, including bearing capacity requirements and settlement determination, overall stability, and the selection of the wall types most feasible for the site.

For standard walls 10 feet in height or less where soft or unstable soils are not present, it is the responsibility of the region Materials Laboratory to perform the geotechnical investigation. If it has been verified that soil conditions are adequate for the proposed standard wall that is less than or equal to 10 feet in height, the region establishes the wall footing location based on the embedment criteria in the *Bridge Design Manual*, or places the bottom of the wall footing below any surficial loose soils. During this process, the region also evaluates other wall types that may be feasible for the site in question.

The *Standard Plans* provides design charts and details for standard reinforced concrete cantilever walls. The *Standard Plans* are used to size the walls and determine the factored bearing pressure to compare with the factored bearing resistance determined from the geotechnical investigation. The charts provide maximum soil pressure for the LRFD service, strength, and extreme event limit states. Factored bearing resistance for the LRFD service, strength, and extreme event limit states can be obtained from the HQ Geotechnical Office for standard walls over 10 feet in height and from the region Materials Laboratory for standard walls less than or equal to 10 feet in height. The *Standard Plans* can be used for the wall design if the factored bearing resistance exceeds the maximum soil pressure shown in the *Standard Plans* for the respective LRFD limit states.

Contact the HQ Bridge and Structures Office if the factored bearing resistance provided by the geotechnical investigation does not exceed the maximum soil pressure shown in the *Standard Plans* for one or all of the LRFD limit states. The wall is considered a nonstandard wall design and the *Standard Plans* cannot be used.

If the standard wall must support surcharge loads from bridge or building foundations, other retaining walls, noise walls, or other types of surcharge loads, a special wall design is required. The wall is considered to be supporting the surcharge load and is treated as a nonstandard wall if the surcharge load is located within a 1H:1V slope projected up from the bottom of the back of the wall. Contact the HQ Bridge and Structures Office for assistance

The *Standard Plans* provides eight types of reinforced concrete cantilever walls (which represent eight loading cases). Reinforced concrete retaining walls Types 5 through 8 are not designed to withstand western Washington earthquake forces and are not to be used in western Washington (west of the Cascade crest).

Once the geotechnical and architectural assessments have been completed, the region completes the PS&E for the standard wall option(s) selected, including a generalized wall profile and plan, a typical cross section as appropriate, and details for desired wall appurtenances, drainage details, and other details as needed.

Metal bin walls, Types 1 and 2, have been deleted from the *Standard Plans* and are therefore no longer standard walls. Metal bin walls are seldom used due to cost and undesirable aesthetics. If this type of wall is proposed, contact the HQ Bridge and Structures Office for plan details and toe bearing pressures. The applied toe bearing pressure will then have to be evaluated by the HQ Geotechnical Office to determine whether the site soil conditions are appropriate for the applied load and anticipated settlement.

**(b) Preapproved Proprietary Walls**

Final approval of preapproved proprietary wall design, with the exception of geosynthetic walls, is the responsibility of the HQ Bridge and Structures Office. Final approval of the design of preapproved proprietary geosynthetic walls is the responsibility of the HQ Geotechnical Office. It is the region's responsibility to coordinate the design effort for all preapproved wall systems.



The region Materials Laboratory performs the geotechnical investigation for preapproved proprietary walls 10 feet in height or less that are not bearing on soft or unstable soils. In all other cases, it is the responsibility of the HQ Geotechnical Office to conduct, or review and approve, the geotechnical investigation for the wall. The region also coordinates with the State Bridge and Structures Architect to ensure that the wall options selected meet the aesthetic requirements for the site.

Once the geotechnical and architectural assessments have been completed and the desired wall alternatives selected, it is the responsibility of the region to contact the suppliers of the selected preapproved systems to confirm in writing the adequacy and availability of the systems for the proposed use.

Include a minimum of three different wall systems in the PS&E for any project with federal participation that includes a proprietary wall system unless specific justification is provided. Standard walls can be alternatives.

Once confirmation of adequacy and availability has been received, the region contacts the HQ Bridge and Structures Office for special provisions for the selected wall systems and proceeds to finalize the contract PS&E in accordance with the *Plans Preparation Manual*. Provide the allowable bearing capacity and foundation embedment criteria for the wall, as well as backfill and foundation soil properties, in the Special Provisions. In general, assume that gravel borrow or better-quality backfill material will be used for the walls when assessing soil parameters.

Complete wall plans and designs for the proprietary wall options will not be developed until after the contract is awarded, but will be developed by the proprietary wall supplier as shop drawings after the contract is awarded. Therefore, include a general wall plan; a profile showing neat line top and bottom of the wall; a final ground line in front of and in back of the wall; a typical cross-section; and the generic details for the desired appurtenances and drainage requirements in the contract PS&E for the proprietary walls. Estimate the ground line in back of the wall based on a nominal 1.5-foot facing thickness (and state this on the wall plan sheets). Include load or other design acceptance requirements for these appurtenances in the PS&E. Contact the HQ Bridge and Structures Office for assistance.

It is best to locate catch basins, grate inlets, signal foundations, and the like outside the reinforced backfill zone of MSE walls to avoid interference with the soil reinforcement. In those cases where conflict with these reinforcement obstructions cannot be avoided, indicate the location(s) and dimensions of the reinforcement obstruction(s) relative to the wall on the plans. Contact the HQ Bridge and Structures Office for preapproved wall details and designs for size and location of obstructions and to obtain the generic details that are to be provided in the plans. If the obstruction is too large or too close to the wall face, a special design may be required to accommodate the obstruction, and the wall is treated as a nonpreapproved proprietary wall.

A special design is required if the wall will support structure foundations, other retaining walls, noise walls, signs or sign bridges, luminaires, or other types of surcharge loads. The wall is considered to be supporting the surcharge load if the surcharge is located within a 1H:1V slope projected from the bottom of the

back of the wall. For MSE walls, the back of the wall is considered to be the back of the soil reinforcement layers. If this situation occurs, the wall is treated as a nonpreapproved proprietary wall.

For those alternative wall systems that have the same face embedment criteria, the wall face quantities depicted in the plans for each alternative are to be identical. To provide an equal basis for competition, the region determines wall face quantities based on neat lines.

Once the detailed wall plans and designs are available as shop drawings after contract award, the HQ Bridge and Structures Office will review and approve the wall shop drawings and calculations, with the exception of geosynthetic walls. They are reviewed and approved by the HQ Geotechnical Office.

**(c) Nonpreapproved Proprietary Walls**

Final approval authority for nonpreapproved proprietary wall design is the same as for preapproved proprietary walls. The region initiates the design effort for all nonpreapproved wall systems by submitting wall plan, profile, cross section, and other information for the proposed wall to the HQ Bridge and Structures Office, with copies to the HQ Geotechnical Office and the State Bridge and Structures Architect. The HQ Bridge and Structures Office coordinates the wall design effort.

Once the geotechnical and architectural assessments have been completed and the desired wall types selected, the HQ Bridge and Structures Office contacts suppliers of the selected nonpreapproved wall systems to obtain and review detailed wall designs and plans to be included in the contract PS&E.

To ensure fair competition between all wall alternatives included in the PS&E, make the wall face quantities identical for those wall systems subject to the same face embedment requirements.

The HQ Bridge and Structures Office develops the special provisions and cost estimates for the nonpreapproved proprietary walls and sends the wall PS&E to the region for inclusion in the final PS&E in accordance with the *Plans Preparation Manual*.

**(d) Nonstandard Nonproprietary Walls**

With the exception of rockeries over 5 feet high, nonproprietary geosynthetic walls and reinforced slopes, and soil nail walls, the HQ Bridge and Structures Office coordinates with the HQ Geotechnical Office and the State Bridge and Structures Architect to carry out the design of all nonstandard, nonproprietary walls. The HQ Bridge and Structures Office develops the wall preliminary plan from site data provided by the region, completes the wall design, and develops the nonstandard nonproprietary wall PS&E package for inclusion in the contract.

For rockeries over 5 feet high, nonproprietary geosynthetic walls and reinforced slopes, and soil nail walls, the region develops wall/slope profiles, plans, and cross sections and submits them to the HQ Geotechnical Office to complete a detailed wall/slope design.

For geosynthetic walls and slopes and for rockeries, the region provides overall coordination of the wall/slope design effort, including coordination with the State Bridge and Structures Architect regarding aesthetics and finishes, and the region or HQ Landscape Architect if the wall uses vegetation on the face.

The HQ Geotechnical Office has overall approval authority for the wall design. Once the wall design has been completed, the HQ Geotechnical Office, and in some cases the HQ Bridge and Structures Office, provides geotechnical and structural plan details to be included in the region plan sheets and special provisions for the PS&E. The region then completes the PS&E package.

For soil nail walls, once the HQ Geotechnical Office has performed the geotechnical design, the HQ Bridge and Structures Office, in cooperation with the HQ Geotechnical Office, coordinates the design effort and completes the PS&E package.

### **(3) Guidelines for Wall/Slope Data Submission for Design**

#### **(a) Standard Walls, Proprietary Walls, Geosynthetic Walls/Slopes, and Soil Nail Walls**

Where Headquarters involvement in retaining wall/slope design is required (as it is for standard walls and preapproved proprietary walls over 10 feet in height, gabions over 6 feet in height, rockeries over 5 feet in height, all nonpreapproved proprietary walls, geosynthetic walls/slopes, and all soil nail walls), the region submits the following information to the HQ Geotechnical Office or HQ Bridge and Structures Office as appropriate:

- Wall/slope plans.
- Profiles showing the existing and final grades in front of and behind the wall.
- Wall/slope cross sections (typically every 50 feet) or CAiCE files that define the existing and new ground line above and below the wall/slope and show stations and offsets.
- Location of right of way lines and other constraints to wall/slope construction.
- Location of adjacent existing and/or proposed structures, utilities, and obstructions.
- Desired aesthetics.
- Date design must be completed.
- Key region contacts for the project.

Note that for the purpose of defining the final wall geometry, it is best to base existing ground measurements on physical survey data rather than solely on photogrammetry. In addition, the region is to complete a Retaining Wall/Reinforced Slope Site Data Check List, DOT Form 351-009 EF, for each wall or group of walls submitted.

#### **(b) Nonstandard Walls, Except Geosynthetic Walls/Slopes and Soil Nail Walls**

In this case, the region is to submit site data in accordance with [Chapter 710](#). Additionally, the region is to complete a Retaining Wall/Reinforced Slope Site Data Check List, DOT Form 351-009 EF, for each wall or group of walls.

## **730.07 Documentation**

Refer to [Chapter 300](#) for design documentation requirements.

Specific Wall Type	Advantages	Disadvantages	Limitations
Steel soil reinforcement with full height precast concrete panels	Relatively low cost.	Can tolerate little settlement; generally requires high-quality backfill; wide base width required (70% of wall height).	Applicable primarily to fill situations; maximum feasible height is approximately 20 feet.
Steel soil reinforcement with modular precast concrete panels	Relatively low cost; flexible enough to handle significant settlement.	Generally requires high-quality backfill; wide base width required (70% of wall height).	Applicable primarily to fill situations; maximum height of 33 feet; heights over 33 feet require a special design.
Steel soil reinforcement with welded wire and cast-in-place concrete face	Can tolerate large short-term settlements.	Relatively high cost; cannot tolerate long-term settlement; generally requires high-quality wall backfill soil; wide base width required (70% of wall height); typically requires a settlement delay during construction.	Applicable primarily to fill situations; maximum height of 33 feet for routine designs; heights over 33 feet require a special design.
Steel soil reinforcement with welded wire face only	Can tolerate large short-term settlements; low cost.	Aesthetics, unless face plantings can be established; generally requires high-quality backfill; wide base width required (70% of wall height).	Applicable primarily to fill situations; maximum height of 33 feet for routine designs; heights over 33 feet require a special design.
Segmental masonry concrete block-faced walls, generally with geosynthetic soil reinforcement	Low cost; flexible enough to handle significant settlement.	Internal wall deformations may be greater for steel reinforced systems, but are acceptable for most applications; generally requires high-quality backfill; wide base required (70% of wall height).	Applicable primarily to fill situations; in general, limited to a wall height of 20 feet or less; greater wall heights may be feasible by special design in areas of low seismic activity and when geosynthetic products are used in which long-term product durability is well defined. (See <i>Qualified Products List</i> .)
Geosynthetic walls with a shotcrete or cast-in-place concrete face	Very low cost, especially with shotcrete face; can tolerate large short-term settlements.	Internal wall deformations may be greater than for steel reinforced systems, but are still acceptable for most applications; generally requires high-quality backfill; wide base width required (70% of wall height).	Applicable primarily to fill situations; in general, limited to wall height of 20 feet or less unless using geosynthetic products in which long-term product durability is well defined. (See <i>Qualified Products List</i> .) For qualified products, heights of 33 feet or more are possible.

**Summary of Mechanically Stabilized Earth (MSE) Gravity  
Wall/Slope Options Available**  
*Exhibit 730-1*

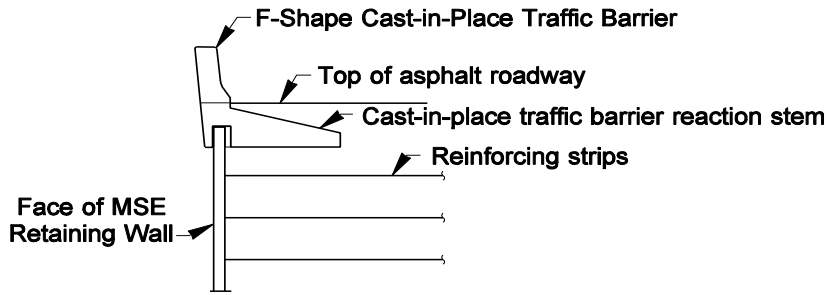

**Concrete Traffic Barrier with Asphalt Roadway**

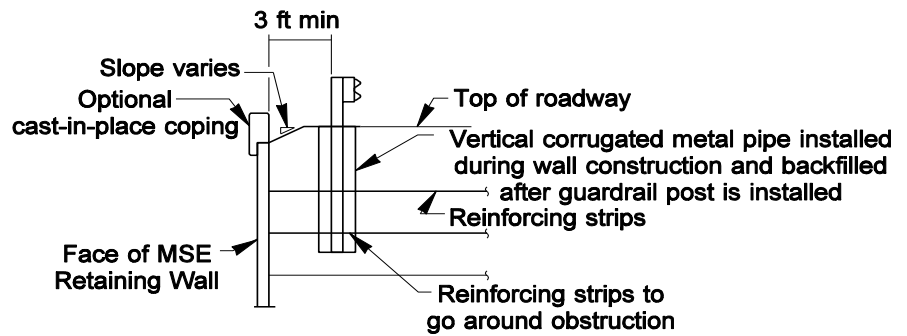

**Beam Guardrail on Top of MSE Retaining Wall**

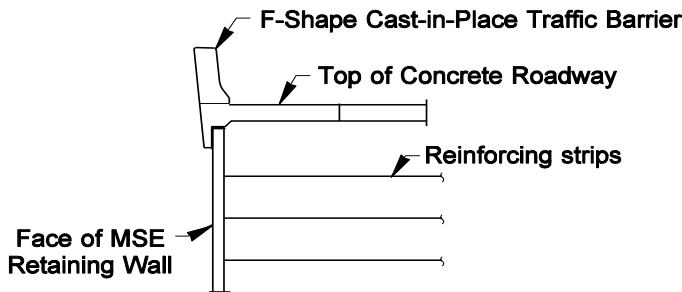

**Concrete Traffic Barrier with Concrete Roadway**

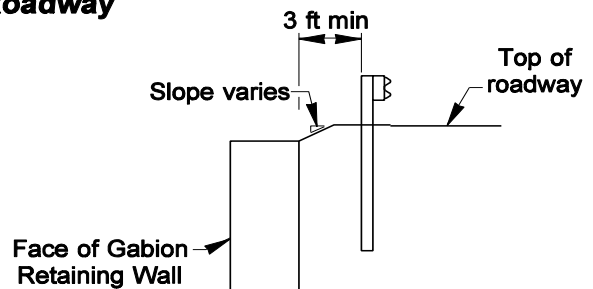

**Beam Guardrail on Top of Gabion Wall**

**Retaining Walls With Traffic Barriers**

Exhibit 730-12

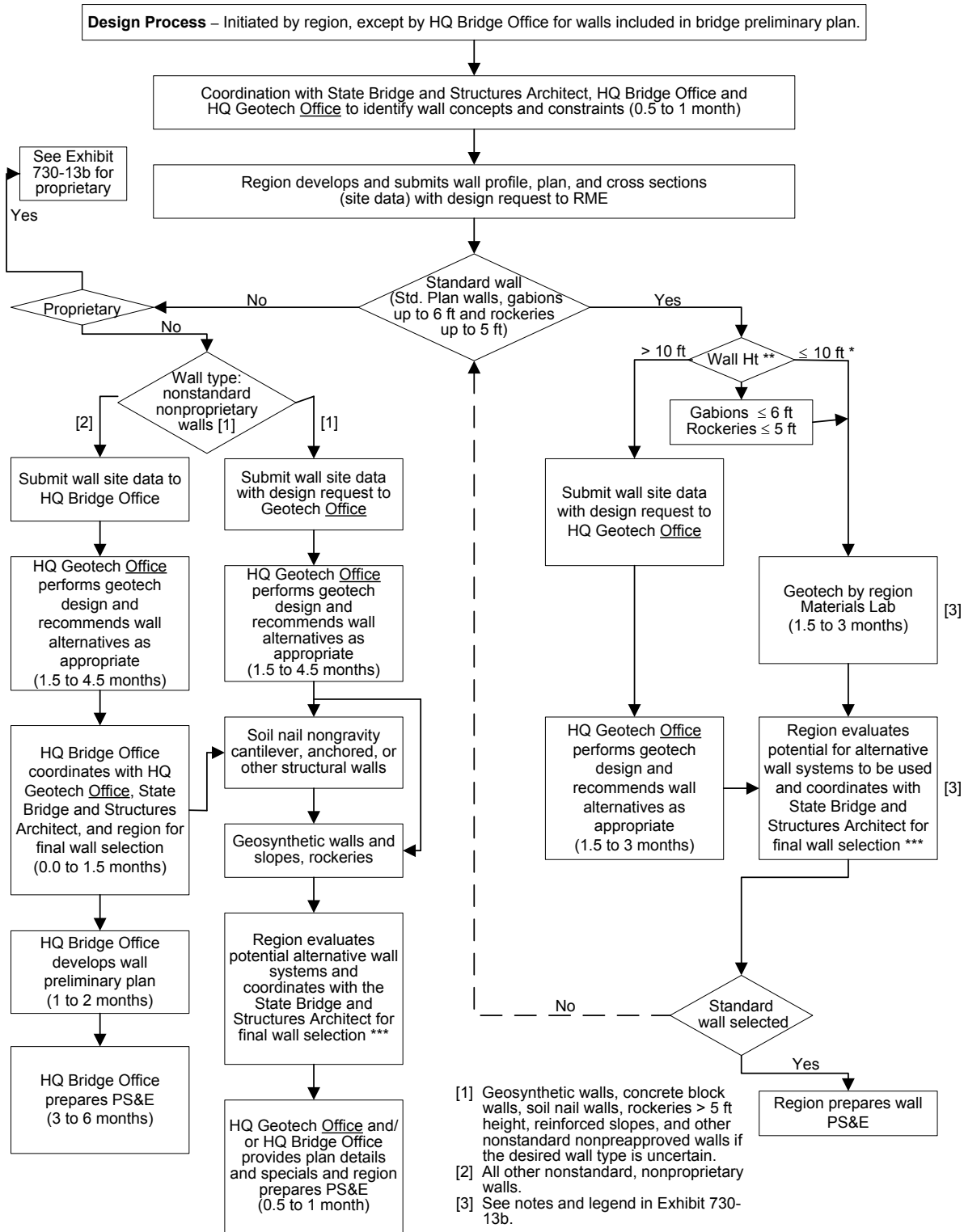

**Retaining Wall Design Process**  
Exhibit 730-13a

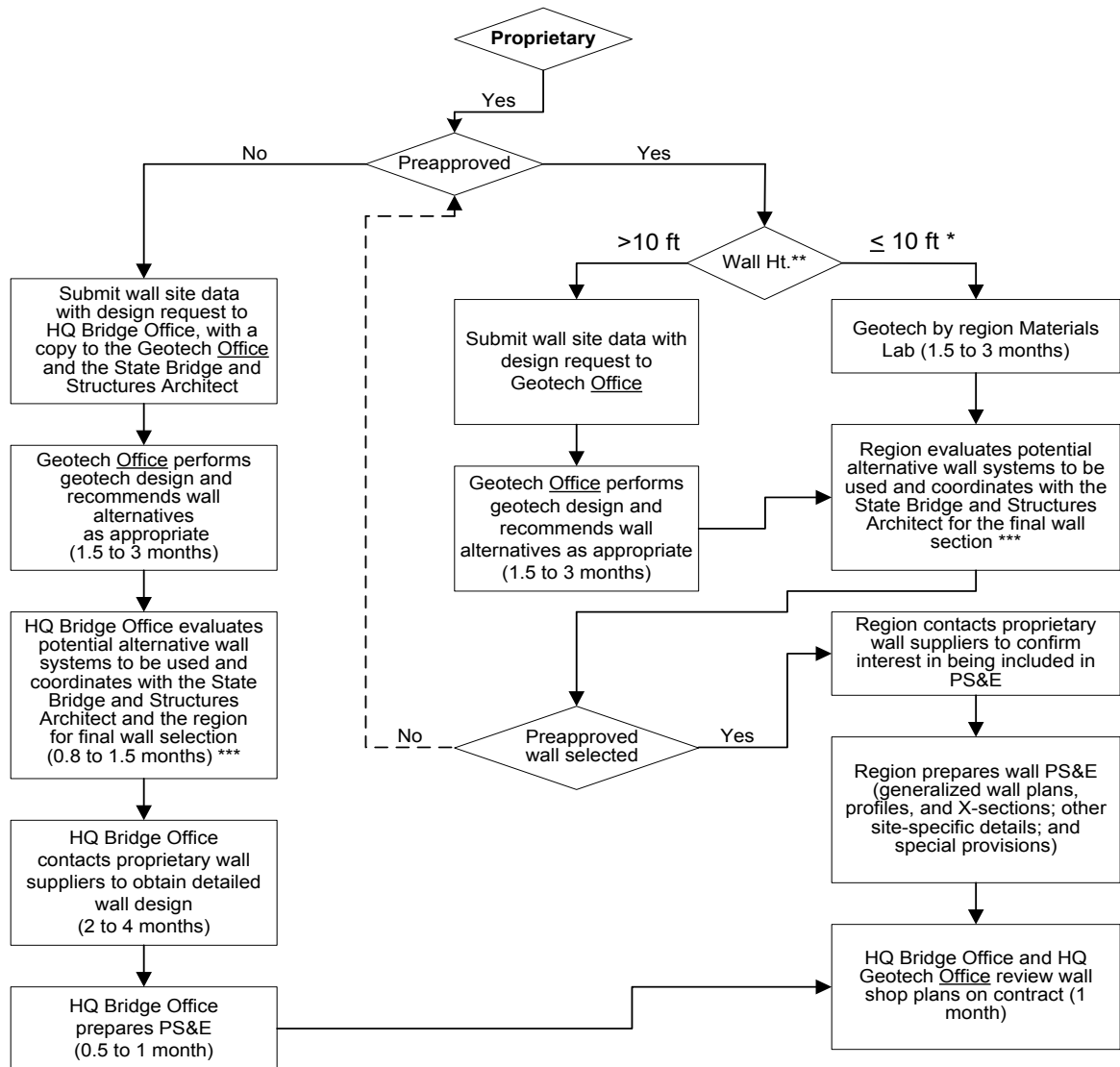

**Notes:**

"HQ Bridge Office" refers to the WSDOT HQ Bridge and Structures Office.

"Geotech Office" refers to the WSDOT HQ Geotechnical Office.

"State Bridge and Structures Architect" refers to the Architecture Section, HQ Bridge and Structures Office.

Regarding time estimates:

- Assumes no major changes in the wall scope during design.
- Actual times may vary depending on complexity of project.
- Contact appropriate design offices for more accurate estimates of time.

**Legend:**

Region provides courtesy copy of geotechnical report to HQ Geotechnical Office.

\*Assumes soft or unstable soil not present and wall does not support other structures.

\*\*The preapproved maximum wall height is generally 33 feet. Some proprietary walls might be less. (Check with the HQ Bridge and Structures Office.)

\*\*\*If the final wall selected is a different type than assumed, go back through the design process to ensure that all the steps have been taken.

**Retaining Wall Design Process: Proprietary**  
*Exhibit 730-13b*





## 740.04 Procedures

The noise unit notifies the Project Engineer's Office when a noise barrier is recommended in the noise report.

The Project Engineer's Office is responsible for interdisciplinary teams, consultation, and coordination with the public, noise specialists, maintenance, construction, region Landscape Architecture Office (or the HQ Roadside and Site Development Section), right of way personnel, Materials Laboratory, State Bridge and Structures Architect, HQ Bridge and Structures Office, CAE Support Team, HQ Development Services & Access Manager, consultants, and many others.

If a noise wall is contemplated, the region evaluates the soils (see Chapters [610](#) and [710](#)) and obtains a list of acceptable wall design options. The list is obtained by sending information pertaining to soils and drainage conditions, alignment, and height of the proposed wall to the State Bridge and Structures Architect.

If a vegetated earth berm is considered, see the [Roadside Manual](#) for procedures.

The State Bridge and Structures Architect coordinates with the HQ Bridge and Structures Office, HQ Hydraulics Section, HQ Geotechnical Office, and the region to provide a list of acceptable standard, draft-standard, and preapproved proprietary noise wall designs, materials, and finishes that are compatible with existing visual elements of the corridor. Only wall designs from this list may be considered as alternatives. Limit design visualizations of the highway side of proposed walls (available from the CAE Support Team in Olympia) to options from this list. The visual elements of the private property side of a wall are the responsibility of the region unless addressed in the environmental documents.

After the noise report is completed, any changes to the dimensions or location of a noise barrier must be reviewed by the appropriate noise unit to determine the impacts of the changes on noise abatement.

On limited access highways, coordinate any opening in a wall or fence (for pedestrians or vehicles) with the HQ Development Services & Access Manager and obtain approval from the Director & State Design Engineer, Development Division.

On nonlimited access highways, an access connection permit is required for any opening (approach) in a wall or fence.

The HQ Bridge and Structures Office provides special substructure designs to the regions upon request; reviews contract design data related to standard, draft-standard, and preapproved designs; and reviews plans and calculations that have been prepared by others (see [Chapter 710](#)).

Approval by the State Bridge and Structures Architect is required for any attachment or modification to a noise wall and for the design, appearance, and finish of door and gate-type openings.

Approval by the State Bridge and Structures Architect is also required for the final selection of noise wall appearance, finish, materials, and configuration.

## 740.05 Documentation

Refer to [Chapter 300](#) for design documentation requirements.



800.01	General
800.02	References
800.03	Hydraulic Considerations
800.04	Safety Considerations
800.05	Design Responsibility
800.06	Documentation

### 800.01 General

Hydraulic design factors can significantly influence the corridor, horizontal alignment, grade, location of interchanges, and necessary appurtenances required to convey water across, along, away from, or to a highway or highway facility. An effective hydraulic design conveys water in the most economical, efficient, and practical manner to ensure reasonable public safety without incurring excessive maintenance costs or appreciably damaging the highway or highway facility, adjacent property, or the total environment.

This chapter is intended to serve as a guide to highway designers so they can identify and consider hydraulic-related factors that impact design. Detailed criteria and methods that govern highway hydraulic design are in the Washington State Department of Transportation (WSDOT) *Hydraulics Manual* and *Highway Runoff Manual*.

Some drainage, flood, and water quality problems can be easily recognized and resolved; others might require extensive investigation before a solution is developed. Specialists experienced in hydrology and hydraulics can contribute substantially to the planning and project definition phases of a highway project by recognizing potentially troublesome locations, making investigations, and recommending practical solutions. Regions may request that the Headquarters (HQ) Hydraulics Section provide assistance regarding hydraulic problems.

Since hydraulic factors can affect the design of a proposed highway or highway facility from its inception, consider these factors at the earliest possible time during the planning phase.

In the project definition phase, begin coordination with all state and local governments and Indian tribes that issue or approve permits for the project.

### 800.02 References

#### (1) Design Guidance

*Highway Runoff Manual*, M 31-16, WSDOT

*Hydraulics Manual*, M 23-03, WSDOT

*Standard Plans for Road, Bridge, and Municipal Construction (Standard Plans)*, M 21-01, WSDOT

*Standard Specifications for Road, Bridge, and Municipal Construction (Standard Specifications)*, (Amendments and General Special Provisions), M 41-10, WSDOT

*Utilities Manual*, M 22-87, WSDOT

## (2) *Special Criteria*

Special criteria for unique projects are available by request from the HQ Hydraulics Section.

## 800.03 Hydraulic Considerations

### (1) *The Flood Plain*

Encroachment of a highway or highway facility into a flood plain might present significant problems. A thorough investigation includes the following:

- The effect of the design flood on the highway or highway facility and the required protective measures.
- The effect of the highway or highway facility on the upstream and downstream reaches of the stream and the adjacent property.
- Compliance with hydraulic-related environmental concerns and hydraulic aspects of permits from other governmental agencies per Chapter [225](#).

Studies and reports published by the Federal Emergency Management Agency (FEMA) and the U.S. Army Corps of Engineers are very useful for flood plain analyses. The HQ Hydraulics Section has access to all available reports and can provide any necessary information to the region.

### (2) *Stream Crossings*

When rivers, streams, or surface waters (wetland) are crossed with bridges or culverts (including open-bottom arches and three-sided box culverts), consider:

- Locating the crossing where the stream is most stable.
- Effectively conveying the design flow(s) at the crossing.
- Providing for passage of material transported by the stream.
- The effects of backwater on adjacent property.
- Avoiding large skews at the crossing.
- The effects on the channel and embankment stability upstream and downstream from the crossing.
- Location of confluences with other streams or rivers.
- Fish and wildlife migration.
- Minimizing disturbance to the original streambed.
- Minimizing wetland impact.

For further design details, see the [Hydraulics Manual](#).

### 1010.03 Definitions

**transportation management plan (TMP)** A set of traffic control plans, transportation operations plans, and public information strategies for managing the work zone impacts of a project. A TMP is required for all projects to address work zone safety and mobility impacts.

**traveling public** Motorists, motorcyclists, bicyclists, pedestrians, and pedestrians with disabilities.

**work zone** An area of a highway with construction, maintenance, or utility work activities. A work zone is identified by the placement of temporary traffic control devices that may include signs, channelizing devices, barriers, pavement markings, and/or work vehicles with warning lights. It extends from the first warning sign or high-intensity rotating, flashing, oscillating, or strobe lights on a vehicle to the END ROAD WORK sign or the last temporary traffic control device (MUTCD).

**work zone impact** Highway construction, maintenance, or utility work operations in the traveled way, adjacent to the traveled way, or within the highway's right of way that creates safety and mobility concerns for workers or the traveling public.

**work zone traffic control** The planning, design, and preparation of contract documents for the modification of traffic patterns due to work zone impacts.

### 1010.04 Work Zone Safety and Mobility

In September 2004, the Federal Highway Administration (FHWA) published updates to the work zone regulations in [23 CFR 630 Subpart J](#), Work Zone Safety and Mobility. The updated regulation is referred to as “the Final Rule” on work zone safety and mobility and applies to all state and local governments that receive federal-aid highway funding. At the heart of the Rule is a requirement for agencies to develop an agency-level work zone safety and mobility policy. The policy is intended to support systematic consideration and management of work zone impacts across all stages of project development. Also required by the Rule is the development of processes and procedures to sustain the policy and transportation management plans (TMPs) for project-level procedures to manage work zone impacts.

WSDOT policy and the guidance to carry out the policy are outlined in [Executive Order E 1001, Work Zone Safety and Mobility](#). The policy states:

*All WSDOT employees are directed to make the safety of workers and the traveling public our highest priority during roadway design, construction, maintenance, and related activities.*

Designers need to be familiar with this document. The policy defines how WSDOT programs address work zone safety and mobility issues during project planning, design, and construction, and during highway maintenance.

### 1010.05 Transportation Management Plans and Significant Projects

#### (1) Transportation Management Plan (TMP)

A transportation management plan is a set of strategies for managing the corridor-wide work zone impacts of a project. A TMP is required for all projects and is a key element

in addressing all work zone safety and mobility impacts. The TMP development begins in the scoping phase of a project by gathering project information, traffic data, impacts assessments, strategies, and mitigation and design solutions.

The three major components of a TMP are described below.

**(a) Temporary Traffic Control (TTC)**

- Control Strategies: Could include staged construction, full road closures, lane shifts or closures, night work, or one-lane two-way operations (flagging and or pilot car).
- Traffic Control Devices: Temporary signing, channelizing devices (cones, drums), changeable message signs, arrow panels, temporary signals, and temporary pavement markings.
- Project Coordination, Contracting Strategies, and Innovative Construction Strategies: A+B bidding, incentives/disincentives, and precast members or rapid cure materials.

These strategies are to be included in the Plans, Specifications, and Estimates (PS&E) as traffic control plans (TCPs) and contract provisions.

**(b) Transportation Operations (TO)**

- Demand Management Strategies: Transit service improvements, transit incentives, and park & ride promotion.
- Corridor/Network Management (traffic operations) Strategies: Signal timing/coordination improvements, temporary signals, bus pullouts, reversible lanes, and truck/heavy-vehicle restrictions.
- Work Zone Safety Management Strategies: Speed limit reductions, barrier and attenuators, and automated flagger assistance devices.
- Traffic/Incident Management and Enforcement Strategies: Work Zone Intelligent Transportation Systems (ITS), Washington State Patrol, tow service, WSDOT Incident Management vehicle(s), and traffic screens.

Some of these strategies may be included in the PS&E, but could also be WSDOT-managed elements outside the contract.

**(c) Public Information (PI)**

- Public Awareness Strategies: Brochures or mailers, press releases, paid advertisements, and project website (consider providing information in other languages if appropriate).
- Motorist Information Strategies: Highway advisory radio (HAR), changeable message signs, and transportation management center (TMC).

Public awareness strategies may be developed and implemented by WSDOT through the region or Headquarters (HQ) Communications offices and implemented before and during construction. Motorist information strategies may be WSDOT-managed elements with state equipment outside the contract or identified on plans in the PS&E.

Refer to the *Rule on Work Zone Safety and Mobility* at:

[http://www.ops.fhwa.dot.gov/wz/resources/publications/trans\\_mgmt\\_plans/trans\\_mgmt\\_plans.pdf](http://www.ops.fhwa.dot.gov/wz/resources/publications/trans_mgmt_plans/trans_mgmt_plans.pdf)



Washington State  
Department of Transportation

---

# Design Manual

## Volume 2 – Design Criteria

M 22-01.10

July 2013

Division 11 – Project Design Criteria

Division 12 – Geometrics

Division 13 – Intersections and Interchanges

Division 14 – HOV and Transit

Division 15 – Pedestrian and Bicycle Facilities

Division 16 – Roadside Safety Elements

Division 17 – Roadside Facilities

**Engineering and Regional Operations**

Development Division, Design Office

## **Americans with Disabilities Act (ADA) Information**

Materials can be provided in alternative formats by calling the ADA Compliance Manager at 360-705-7097. Persons who are deaf or hard of hearing may contact that number via the Washington Relay Service at 7-1-1.

## **Title VI Notice to Public**

It is Washington State Department of Transportation (WSDOT) policy to ensure no person shall, on the grounds of race, color, national origin, or sex, as provided by Title VI of the Civil Rights Act of 1964, be excluded from participation in, be denied the benefits of, or be otherwise discriminated against under any of its federally funded programs and activities. Any person who believes his/her Title VI protection has been violated may file a complaint with WSDOT's Office of Equal Opportunity (OEO). For Title VI complaint forms and advice, please contact OEO's Title VI Coordinator at 360-705-7082 or 509-324-6018.

To get the latest information on individual WSDOT publications, sign up for e-mail updates at:  
 [www.wsdot.wa.gov/publications/manuals](http://www.wsdot.wa.gov/publications/manuals)



**Division 11 – Project Design Criteria****Chapter 1100 Design Matrix Procedures**

- 1100.01 General
- 1100.02 Selecting a Design Matrix
- 1100.03 Using a Design Matrix

**Chapter 1110 Minor Operational Enhancement Projects**

- 1110.01 General
- 1110.02 References
- 1110.03 Definitions
- 1110.04 Minor Operational Enhancement Matrix Procedures
- 1110.05 Selecting a Minor Operational Enhancement Matrix
- 1110.06 Project Type
- 1110.07 Using a Minor Operational Enhancement Matrix
- 1110.08 Project Approval
- 1110.09 Documentation

**Chapter 1120 Basic Design Level**

- 1120.01 General
- 1120.02 Basic Safety
- 1120.03 Minor Safety and Minor Preservation Work
- 1120.04 Documentation

**Chapter 1130 Modified Design Level**

- 1130.01 General
- 1130.02 Design Speed
- 1130.03 Alignment
- 1130.04 Roadway Widths
- 1130.05 Cross Slopes
- 1130.06 Sideslopes
- 1130.07 Bike and Pedestrian
- 1130.08 Bridges
- 1130.09 Intersections
- 1130.10 Documentation

**Chapter 1140 Full Design Level**

- 1140.01 General
- 1140.02 References
- 1140.03 Definitions
- 1140.04 Functional Classification
- 1140.05 Terrain Classification
- 1140.06 Geometric Design Data
- 1140.07 Design Speed
- 1140.08 Traffic Lanes
- 1140.09 Shoulders
- 1140.10 Medians
- 1140.11 Curbs
- 1140.12 Parking
- 1140.13 Pavement Type
- 1140.14 Structure Width

- 1140.15 Right of Way Width
- 1140.16 Grades
- 1140.17 Fencing
- 1140.18 Traffic Signal Control, Illumination, and Intelligent Transportation Systems (ITS)
- 1140.19 Documentation

## Division 12 – Geometrics

### Chapter 1210 Geometric Plan Elements

- 1210.01 General
- 1210.02 References
- 1210.03 Definitions
- 1210.04 Horizontal Alignment
- 1210.05 Distribution Facilities
- 1210.06 Number of Lanes and Arrangement
- 1210.07 Pavement Transitions
- 1210.08 Procedures
- 1210.09 Documentation

### Chapter 1220 Geometric Profile Elements

- 1220.01 General
- 1220.02 References
- 1220.03 Vertical Alignment
- 1220.04 Coordination of Vertical and Horizontal Alignments
- 1220.05 Airport Clearance
- 1220.06 Railroad Crossings
- 1220.07 Procedures
- 1220.08 Documentation

### Chapter 1230 Geometric Cross Section

- 1230.01 General
- 1230.02 References
- 1230.03 Definitions
- 1230.04 Roadways
- 1230.05 Medians and Outer Separations
- 1230.06 Roadsides
- 1230.07 Roadway Sections
- 1230.08 Documentation

### Chapter 1240 Turning Roadways

- 1240.01 General
- 1240.02 References
- 1240.03 Definitions
- 1240.04 Turning Roadway Widths
- 1240.05 Documentation

### Chapter 1250 Superelevation

- 1250.01 General
- 1250.02 References
- 1250.03 Definitions
- 1250.04 Superelevation Rate Selection
- 1250.05 Existing Curves
- 1250.06 Turning Movements at Intersections
- 1250.07 Runoff for Highway Curves
- 1250.08 Runoff for Ramp Curves
- 1250.09 Documentation

**Chapter 1260 Sight Distance**

- 1260.01 General
- 1260.02 References
- 1260.03 Stopping Sight Distance
- 1260.04 Passing Sight Distance
- 1260.05 Decision Sight Distance
- 1260.06 Documentation

**Chapter 1270 Auxiliary Lanes**

- 1270.01 General
- 1270.02 References
- 1270.03 Definitions
- 1270.04 Climbing Lanes
- 1270.05 Passing Lanes
- 1270.06 Slow-Moving Vehicle Turnouts
- 1270.07 Shoulder Driving for Slow Vehicles
- 1270.08 Emergency Escape Ramps
- 1270.09 Chain-Up and Chain-Off Areas
- 1270.10 Documentation

**Division 13 – Intersections and Interchanges****Chapter 1300 Intersection Control Type**

- 1300.01 General
- 1300.02 References
- 1300.03 Intersection Control Objectives
- 1300.04 Common Types of Intersection Control
- 1300.05 Design Vehicle Selection
- 1300.06 Procedures
- 1300.07 Documentation

**Chapter 1310 Intersections**

- 1310.01 General
- 1310.02 References
- 1310.03 Design Considerations
- 1310.04 Design Elements
- 1310.05 U-Turns
- 1310.06 Intersection Sight Distance
- 1310.07 Signing and Delineation
- 1310.08 Procedures
- 1310.09 Documentation

**Chapter 1320 Roundabouts**

- 1320.01 General
- 1320.02 References
- 1320.03 Roundabout Types
- 1320.04 Capacity Analysis
- 1320.05 Geometric Design
- 1320.06 Pedestrians
- 1320.07 Bicycles
- 1320.08 Signing and Pavement Marking
- 1320.09 Illumination
- 1320.10 Road Approach, Parking, and Transit Facilities
- 1320.11 Approvals
- 1320.12 Documentation

---

<b>Chapter 1330</b>	<b>Traffic Control Signals</b>
1330.01	General
1330.02	References
1330.03	Definitions
1330.04	Procedures
1330.05	Signal Warrants
1330.06	Conventional Traffic Signal Design
1330.07	Documentation
<b>Chapter 1340</b>	<b>Driveways</b>
1340.01	General
1340.02	References
1340.03	Design Considerations
1340.04	Driveway Design Templates
1340.05	Sidewalks
1340.06	Driveway Sight Distance
1340.07	Stormwater and Drainage
1340.08	Mailboxes
1340.09	Documentation
<b>Chapter 1350</b>	<b>Railroad Grade Crossings</b>
1350.01	General
1350.02	References
1350.03	Plans
1350.04	Traffic Control Systems
1350.05	Nearby Roadway Intersections
1350.06	Pullout Lanes
1350.07	Crossing Surfaces
1350.08	Crossing Closure
1350.09	Traffic Control During Construction and Maintenance
1350.10	Railroad Grade Crossing Petitions and WUTC Orders
1350.11	Grade Crossing Improvement Projects
1350.12	Light Rail
1350.13	Documentation
<b>Chapter 1360</b>	<b>Interchanges</b>
1360.01	General
1360.02	References
1360.03	Definitions
1360.04	Interchange Design
1360.05	Ramps
1360.06	Interchange Connections
1360.07	Ramp Terminal Intersections at Crossroads
1360.08	Interchanges on Two-Lane Highways
1360.09	Interchange Plans for Approval
1360.10	Documentation
<b>Chapter 1370</b>	<b>Median Crossovers</b>
1370.01	General
1370.02	Analysis
1370.03	Design
1370.04	Plan Updates and Approvals
1370.05	Documentation

## Division 14 – HOV and Transit

### Chapter 1410 High-Occupancy Vehicle Facilities

- 1410.01 General
- 1410.02 References
- 1410.03 Definitions
- 1410.04 Preliminary Design and Planning
- 1410.05 Operations
- 1410.06 Design Criteria
- 1410.07 Documentation

### Chapter 1420 HOV Direct Access

- 1420.01 General
- 1420.02 References
- 1420.03 Definitions
- 1420.04 HOV Access Types and Locations
- 1420.05 Direct Access Geometrics
- 1420.06 Passenger Access
- 1420.07 Traffic Design Elements
- 1420.08 Documentation

### Chapter 1430 Transit Facilities

- 1430.01 General
- 1430.02 References
- 1430.03 Definitions
- 1430.04 Park & Ride Lots
- 1430.05 Transfer/Transit Centers
- 1430.06 Bus Stops and Pullouts
- 1430.07 Passenger Amenities
- 1430.08 Roadway Design and Design Vehicle Characteristics
- 1430.09 Intersection Radii
- 1430.10 Universal Access
- 1430.11 Documentation

## Division 15 – Pedestrian and Bicycle Facilities

### Chapter 1510 Pedestrian Facilities

- 1510.01 General
- 1510.02 References
- 1510.03 Definitions
- 1510.04 Policy
- 1510.05 ADA Requirements by Project Type
- 1510.06 Pedestrian Circulation Paths
- 1510.07 Pedestrian Access Routes (PARs)
- 1510.08 Sidewalks
- 1510.09 Curb Ramps
- 1510.10 Crosswalks
- 1510.11 Raised Medians/Traffic Islands
- 1510.12 Pedestrian Pushbuttons at Signals
- 1510.13 At-Grade Railroad Crossings
- 1510.14 Pedestrian Grade Separations (Structures)
- 1510.15 Other Pedestrian Facilities
- 1510.16 Illumination and Signing
- 1510.17 Work Zone Pedestrian Accommodation
- 1510.18 Documentation

**Chapter 1515 Shared-Use Paths**

- 1515.01 General
- 1515.02 References
- 1515.03 Definitions
- 1515.04 Shared-Use Path Design – The Basics
- 1515.05 Intersections and Crossings Design
- 1515.06 Grade Separation Structures
- 1515.07 Signing, Pavement Markings, and Illumination
- 1515.08 Restricted Use Controls
- 1515.09 Documentation

**Chapter 1520 Roadway Bicycle Facilities**

- 1520.01 General
- 1520.02 References
- 1520.03 Definitions
- 1520.04 Facility Selection
- 1520.05 Project Requirements
- 1520.06 Shared-Use Path Design
- 1520.07 Shared Roadway Bicycle Facility Design
- 1520.08 Signed Shared Bicycle Roadway Design
- 1520.09 Bicycle Lane Design
- 1520.10 Documentation

**Division 16 – Roadside Safety Elements****Chapter 1600 Roadside Safety**

- 1600.01 General
- 1600.02 References
- 1600.03 Clear Zone
- 1600.04 Features to Be Considered for Mitigation
- 1600.05 Median Considerations
- 1600.06 Other Roadside Safety Features
- 1600.07 Documentation

**Chapter 1610 Traffic Barriers**

- 1610.01 General
- 1610.02 References
- 1610.03 Definitions
- 1610.04 Project Criteria
- 1610.05 Barrier Design
- 1610.06 Beam Guardrail
- 1610.07 Cable Barrier
- 1610.08 Concrete Barrier
- 1610.09 Special-Use Barriers
- 1610.10 Bridge Traffic Barriers
- 1610.11 Other Barriers
- 1610.12 Documentation

**Chapter 1620 Impact Attenuator Systems**

- 1620.01 General
- 1620.02 Design Criteria
- 1620.03 Selection
- 1620.04 Documentation

---

## Division 17 – Roadside Facilities

### Chapter 1710 Safety Rest Areas and Traveler Services

- 1710.01 General
- 1710.02 References
- 1710.03 Definitions
- 1710.04 Safety Rest Area Project Team
- 1710.05 Location, Access, and Site Design
- 1710.06 Buildings
- 1710.07 Utilities
- 1710.08 Documentation

### Chapter 1720 Weigh Sites

- 1720.01 General
- 1720.02 Definitions
- 1720.03 Planning, Development, and Responsibilities
- 1720.04 Permanent Facilities
- 1720.05 Portable Facilities
- 1720.06 Shoulder Sites
- 1720.07 Federal Participation
- 1720.08 Procedures
- 1720.09 Documentation





1100-1	Design Matrix Selection Guide
1100-2	Design Matrix 1: Interstate Routes (Main Line)
1100-3	Design Matrix 2: Interstate Interchange Areas
1100-4	Design Matrix 3: Main Line NHS Routes (Except Interstate)
1100-5	Design Matrix 4: Interchange Areas, NHS (Except Interstate), and Non-NHS
1100-6	Design Matrix 5: Main Line Non-NHS Routes
1100-7	Design Matrix Notes
1110-1	Minor Operational Enhancement Matrix Selection Guide
1110-2	Minor Operational Enhancement Matrix 1: Interstate and NHS Freeway Routes
1110-3	Minor Operational Enhancement Matrix 2: NHS Nonfreeway Routes
1110-4	Minor Operational Enhancement Matrix 3: Non-NHS Routes
1110-5	Q Project Design Summary/Approval Template
1110-6	Refuge Lane for T-Intersections on Two-Lane Highways
1130-1	Desirable Design Speed
1130-2	Stopping Sight Distance: Modified Design Level
1130-3	Minimum Crest Vertical Curve Length: Modified Design Level
1130-4	Minimum Superelevation: Modified Design Level
1130-5	Side Friction Factor
1130-6	One-Way Roadway and Ramp Turning Roadway Widths: Modified Design Level
1130-7	Design Vehicles: Modified Design Level
1130-8	Evaluation for Stopping Sight Distance for Crest Vertical Curves: Modified Design Level
1130-9a	Evaluation for Stopping Sight Distance for Horizontal Curves: Modified Design Level
1130-9b	Evaluation for Stopping Sight Distance Obstruction for Horizontal Curves: Modified Design Level
1130-10	Multilane Highways and Bridges: Modified Design Level
1130-11	Two-Lane Highways and Bridges: Modified Design Level
1130-12a	Minimum Total Roadway Widths for Two-Lane Two-Way Highway Curves: Modified Design Level
1130-12b	Minimum Total Roadway Widths for Two-Lane Two-Way Highway Curves: Modified Design Level, Based on the Delta Angle
1130-13	Main Line Roadway Sections: Modified Design Level
1130-14	Ramp Roadway Sections: Modified Design Level
1140-1	Desirable Design Speed
1140-2	Minimum Shoulder Width
1140-3	Shoulder Width for Curbed Sections in Urban Areas
1140-4	Median Width
1140-5	Geometric Design Data: Interstate

---

1140-6	Geometric Design Data: Principal Arterial
1140-7	Geometric Design Data: Minor Arterial
1140-8	Geometric Design Data: Collector
1140-9	Geometric Design Data: Urban Managed Access Highways
1210-1	Maximum Angle Without Curve
1210-2a	Alignment Examples
1210-2b	Alignment Examples
1210-2c	Alignment Examples
1220-1	Grade Length
1220-2a	Coordination of Horizontal and Vertical Alignments
1220-2b	Coordination of Horizontal and Vertical Alignments
1220-2c	Coordination of Horizontal and Vertical Alignments
1220-3	Grading at Railroad Crossings
1230-1	Divided Highway Roadway Sections
1230-2	Undivided Multilane Highway Roadway Sections
1230-3	Two-Lane Highway Roadway Sections
1230-4a	Ramp Roadway Sections
1230-4b	Ramp Roadway Sections
1230-5a	Shoulder Details
1230-5b	Shoulder Details
1230-6a	Divided Highway Median Sections
1230-6b	Divided Highway Median Sections
1230-6c	Divided Highway Median Sections
1230-7a	Roadway Sections in Rock Cuts: Design A
1230-7b	Roadway Sections in Rock Cuts: Design B
1230-8	Roadway Sections With Stepped Slopes
1230-9a	Bridge End Slopes
1230-9b	Bridge End Slopes
1240-1a	Traveled Way Width for Two-Lane Two-Way Turning Roadways
1240-1b	Traveled Way Width for Two-Lane Two-Way Turning Roadways: Based on the Delta Angle
1240-2a	Traveled Way Width for Two-Lane One-Way Turning Roadways
1240-2b	Traveled Way Width for Two-Lane One-Way Turning Roadways: Based on the Delta Angle
1240-3a	Traveled Way Width for One-Lane Turning Roadways
1240-3b	Traveled Way Width for One-Lane Turning Roadways: Based on the Delta Angle, Radius on Outside Edge of Traveled Way
1240-3c	Traveled Way Width for One-Lane Turning Roadways: Based on the Delta Angle, Radius on Inside Edge of Traveled Way
1250-1	Minimum Radius for Normal Crown Section

1250-2	Minimum Radius for Existing Curves
1250-3	Side Friction Factor
1250-4a	Superelevation Rates (10% Max)
1250-4b	Superelevation Rates (8% Max)
1250-4c	Superelevation Rates (6% Max)
1250-5	Superelevation Rates for Intersections and Low-Speed Urban Roadways
1250-6a	Superelevation Transitions for Highway Curves
1250-6b	Superelevation Transitions for Highway Curves
1250-6c	Superelevation Transitions for Highway Curves
1250-6d	Superelevation Transitions for Highway Curves
1250-6e	Superelevation Transitions for Highway Curves
1250-7a	Superelevation Transitions for Ramp Curves
1250-7b	Superelevation Transitions for Ramp Curves
1260-1	Design Stopping Sight Distance
1260-2	Design Stopping Sight Distance on Grades
1260-3	Stopping Sight Distance on Grades
1260-4	Stopping Sight Distance: Crest Vertical Curves
1260-5	Sight Distance: Crest Vertical Curve
1260-6	Stopping Sight: Distance for Sag Vertical Curves
1260-7	Sight Distance: Sag Vertical Curve
1260-8	Horizontal Stopping Sight Distance
1260-9	Sight Distance: Horizontal Curves
1260-10	Sight Distance: Overlapping Horizontal and Crest Vertical Curves
1260-11	Existing Stopping Sight Distance
1260-12	Passing Sight Distance
1260-13	Passing Sight Distance: Crest Vertical Curve Calculation
1260-14	Passing Sight Distance: Crest Vertical Curves
1260-15	Decision Sight Distance
1270-1	Climbing Lane Example
1270-2a	Speed Reduction Warrant: Performance for Trucks
1270-2b	Speed Reduction Warrant Example
1270-3	Auxiliary Climbing Lane
1270-4	Passing Lane Example
1270-5	Length of Passing Lanes
1270-6	Passing Lane Configurations
1270-7	Buffer Between Opposing Passing Lanes
1270-8	Auxiliary Passing Lane
1270-9	Slow-Moving Vehicle Turnout
1270-10	Emergency Escape Ramp Example

1270-11	Emergency Escape Ramp Length
1270-12	Rolling Resistance (R)
1270-13	Typical Emergency Escape Ramp
1270-14	Chain Up/Chain Off Area
1300-1	Design Vehicle Types
1300-2	Minimum Intersection Design Vehicle
1310-1	Lane Alignment Taper Rate
1310-2	Ramp Terminal Intersection Details
1310-3	Median at Two-Way Ramp Terminal
1310-4	Intersection Balance Example
1310-5	Diamond Interchange With Advance Storage
1310-6	Initial Ranges for Right-Turn Corner (Simple Curve-Taper)
1310-7a	Left-Turn Storage Guidelines: Two-Lane, Unsignalized
1310-7b	Left-Turn Storage Guidelines: Four-Lane, Unsignalized
1310-8a	Left-Turn Storage Length: Two-Lane, Unsignalized (40 mph)
1310-8b	Left-Turn Storage Length: Two-Lane, Unsignalized (50 mph)
1310-8c	Left-Turn Storage Length: Two-Lane, Unsignalized (60 mph)
1310-9	Left-Turn Storage With Trucks (ft)
1310-10a	Median Channelization: Widening
1310-10b	Median Channelization: Median Width 11 ft or More
1310-10c	Median Channelization: Median Width 23 ft to 26 ft
1310-10d	Median Channelization: Median Width of More Than 26 ft
1310-10e	Median Channelization: Minimum Protected Storage
1310-10f	Median Channelization: Two-Way Left-Turn Lane
1310-11	Right-Turn Lane Guidelines
1310-12	Right-Turn Pocket and Right-Turn Taper
1310-13	Right-Turn Lane
1310-14	Acceleration Lane
1310-15a	Traffic Island Designs
1310-15b	Traffic Island Designs: Compound Curve
1310-15c	Traffic Island Designs
1310-16	U-Turn Spacing
1310-17	U-Turn Roadway
1310-18	U-Turn Median Openings
1310-19a	Sight Distance at Intersections
1310-19b	Sight Distance at Intersections
1320-1	Suggested Initial Design Ranges
1320-2	Radii-Speed Relationship
1320-3	Intersection Sight Distance

---

1330-1	Responsibility for Facilities
1330-2	Standard Intersection Movements and Head Numbers
1330-3	Phase Diagrams: Four-Way Intersections
1330-4	Left-Turn Lane Configuration Examples
1330-5	Example of Closed Pedestrian Crossings
1330-6a	Vacant
1330-6b	Vacant
1330-7	Decision Zone Loop Placement
1330-8	Loop Numbering Layout
1330-9	Signal Display Maximum Heights
1330-10	Signal Display Areas
1330-11a	Strain Pole and Foundation Selection Procedure
1330-11b	Strain Pole and Foundation Selection Procedure
1330-12	Strain Pole and Foundation Selection Example
1330-13	Conduit and Conductor Sizes
1330-14a	Traffic Signal Display Placements
1330-14b	Traffic Signal Display Placements
1330-14c	Traffic Signal Display Placements
1330-14d	Traffic Signal Display Placements
1330-14e	Traffic Signal Display Placements
1330-14f	Traffic Signal Display Placements
1340-1	Driveway Design Template SU-30 and Smaller
1340-2	Driveway Design Template SU-30 and Larger
1340-3	Driveway Sight Distance
1350-1	Sight Distance at Railroad Crossing
1350-2	Typical Pullout Lane at Railroad Crossing
1360-1	Basic Interchange Patterns
1360-2	Interchange Spacing
1360-3	Minimum Ramp Connection Spacing
1360-4	Ramp Design Speed
1360-5	Maximum Ramp Grade
1360-6	Ramp Widths
1360-7a	Lane Balance
1360-7b	Lane Balance
1360-8	Main Line Lane Reduction Alternatives
1360-9	Acceleration Lane Length
1360-10	Deceleration Lane Length
1360-11a	Gore Area Characteristics
1360-11b	Gore Area Characteristics

---

1360-12	Length of Weaving Sections
1360-13a	On-Connection: Single-Lane, Tapered
1360-13b	On-Connection: Single-Lane, Parallel
1360-13c	On-Connection: Two-Lane, Parallel
1360-13d	On-Connection: Two-Lane, Tapered
1360-14a	Off-Connection: Single-Lane, Tapered
1360-14b	Off-Connection: Single-Lane, Parallel
1360-14c	Off-Connection: Single-Lane, One-Lane Reduction
1360-14d	Off-Connection: Two-Lane, Tapered
1360-14e	Off-Connection: Two-Lane, Parallel
1360-15a	Collector-Distributor: Outer Separations
1360-15b	Collector Distributor: Off-Connections
1360-15c	Collector Distributor: On-Connections
1360-16	Loop Ramp Connections
1360-17	Temporary Ramps
1360-18	Interchange Plan
1410-1	Minimum Traveled Way Widths for Articulated Buses
1410-2	Typical HOV Lane Sections
1410-3	Roadway Widths for Two-Lane Ramps With an HOV Lane
1410-4a	Single-Lane Ramp Meter With HOV Bypass
1410-4b	Two-Lane Ramp Meter With HOV Bypass
1410-5a	Enforcement Area: One Direction Only
1410-5b	Enforcement Area: Median
1430-1	Bus Berth Designs
1430-2	Transit Center Sawtooth Bus Berth
1430-3	Bus Turnout Transfer Center
1430-4	Off-Street Transfer Center
1430-5	Minimum Bus Zone Dimensions
1430-6	Bus Stop Pullouts: Arterial Streets
1430-7	Minimum Bus Zone and Pullout After Right-Turn Dimensions
1430-8	Shelter Siting
1430-9	Typical Bus Shelter Design
1430-10	Turning Template for a 40-Foot Bus
1430-11	Turning Template for an Articulated Bus
1430-12	Intersection Design
1430-13	Cross-Street Width Occupied by Turning Vehicle for Various Angles of Intersection and Curb Radii
1430-14	Passenger Loading Pad
1510-1	Pedestrian Circulation Paths
1510-2	Relationship Between Pedestrian Circulation Paths and Pedestrian Access Routes

1510-3	Obstructed Pedestrian Access Route
1510-4	Beveling Options
1510-5	Surface Discontinuities (Noncompliant)
1510-6	Sidewalks With Buffers
1510-7	Typical Sidewalk Designs
1510-8	Typical Driveways
1510-9	Perpendicular Curb Ramp
1510-10	Perpendicular Curb Ramp Common Elements
1510-11	Parallel Curb Ramp
1510-12	Parallel Curb Ramp Common Elements
1510-13	Combination Curb Ramp
1510-14	Typical Curb Ramp Drainage
1510-15	Unmarked Crosswalks
1510-16	Marked Pedestrian Crossing
1510-17	Example of Closed Pedestrian Crossing
1510-18	Midblock Pedestrian Crossing
1510-19	Obstructed Line of Sight at Intersection
1510-20	Improved Line of Sight at Intersection
1510-21	Curb Extension Examples
1510-22	Raised Islands With Curb Ramps and Pedestrian Cut-Throughs
1510-23	Typical Pedestrian Pushbutton
1510-24	Clear Space Parallel and Forward Approach Orientation
1510-25	Accessible Pedestrian Signal Pushbutton Stations
1510-26	Pedestrian Railroad Crossings
1510-27	Pedestrian Railroad Warning Device
1510-28	Pedestrian Bridges
1510-29	Pedestrian Tunnel
1510-30	Access Ramp With Accessible Handrails
1510-31	Work Zones and Pedestrian Facilities
1510-32	Crosswalk Marking and Enhancement Guidelines
1515-1	Shared-Use Path
1515-2	Bicycle Design Speeds
1515-3	Two-Way Shared-Use Path: Independent Alignment
1515-4a	Two-Way Shared-Use Path: Adjacent to Roadway ( $\leq$ 35 mph)
1515-4b	Two-Way Shared-Use Path: Adjacent to Roadway ( $>$ 35 mph)
1515-4c	Two-Way Shared-Use Path: Attached to Roadway ( $>$ 35 mph)
1515-5	Shared-Use Path Side Slopes and Railing
1515-6	Shared-Use Path Landing Profile
1515-7	Shared-Use Path Landing and Rest Area

---

1515-8	Typical Redesign of a Diagonal Midblock Crossing
1515-9	Adjacent Shared-Use Path Intersection
1515-10	Roadway Crossing Refuge Area
1515-11	Shared-Use Path Bridge and Approach Walls
1515-12	Bridge and Pedestrian Rail
1515-13	Shared-Use Path in Limited Access Corridor
1515-14a	Stopping Sight Distance for Downgrades
1515-14b	Stopping Sight Distance for Upgrades
1515-15	Minimum Lengths for Crest Vertical Curves
1515-16	Lateral Clearance for Horizontal Curves
1520-1	Bike Facility Selection
1520-2	Shared Roadway
1520-3	Signed Shared Roadway: Designated Bike Route
1520-4	Bike Lane
1520-5	Typical Urban Bike Lane Cross Sections
1520-6	Typical Bicycle/Auto Movements at Intersection of Multilane Streets
1520-7	Bike Lanes Approaching Motorists' Right-Turn-Only Lanes
1520-8a	Bicycle Crossing of Interchange Ramp
1520-8b	Bicycle Crossing of Interchange Ramp
1520-9	At-Grade Railroad Crossings
1520-10	Barrier Adjacent to Bicycle Facilities
1600-1	City and State Responsibilities and Jurisdictions
1600-2	Design Clear Zone Distance Table
1600-3	Design Clear Zone Inventory Form (# 410-026 EF)
1600-4	Recovery Area
1600-5	Design Clear Zone for Ditch Sections
1600-6	Guidelines for Embankment Barrier
1600-7	Mailbox Location and Turnout Design
1600-8	Glare Screens
1610-1	Type 7 Bridge Rail Upgrade Criteria
1610-2	Longitudinal Barrier Deflection
1610-3	Longitudinal Barrier Flare Rates
1610-4	Traffic Barrier Locations on Slopes
1610-5	Old Type 3 Anchor
1610-6	Guardrail Connections
1610-7	Concrete Barrier Shapes
1610-8	Concrete Barrier Placement Guidance: Assessing Impacts to Wildlife
1610-9	Transitions and Connections
1610-10a	Barrier Length of Need on Tangent Sections



---

1610-10b	Barrier Length of Need
1610-10c	Barrier Length of Need on Curves
1610-10d	W-Beam Guardrail Trailing End Placement for Divided Highways
1610-11	Beam Guardrail Post Installation
1610-12a	Beam Guardrail Terminals
1610-12b	Beam Guardrail Terminals
1610-13a	Single Cable Barrier Placement Locations on Median Slopes
1610-13b	Cable Barrier Locations on Shoulder Slopes
1610-13c	Cable Barrier Placement for Divided Highways
1610-14	Thrie Beam Rail Retrofit Criteria
1620-1	Impact Attenuator Sizes
1620-2a	Impact Attenuator Systems: Permanent Installations
1620-2b	Impact Attenuator Systems: Permanent Installations
1620-2c	Impact Attenuator Systems: Permanent Installations
1620-2d	Impact Attenuator Systems: Permanent Installations
1620-2e	Impact Attenuator Systems: Permanent Installations
1620-3a	Impact Attenuator Systems: Work Zone Installations
1620-3b	Impact Attenuator Systems: Work Zone Installations
1620-4a	Impact Attenuator Systems: Older Systems
1620-4b	Impact Attenuator Systems: Older Systems
1620-5	Impact Attenuator System Comparison
1620-6	Impact Attenuator Distance Beyond Length of Need
1710-1	WSDOT Safety Rest Area
1710-2	WSDOT's SRA Project and Programming Roles
1710-3	Additional Safety Rest Area Resources
1710-4	Roadside Facilities Level of Development
1710-5	Typical Truck Storage
1710-6	WSDOT Safety Rest Area Building – Adaptive Reuse Historic Preservation
1720-1	Truck Weigh Site: Multilane Highways
1720-2	Truck Weigh Site: Two-Lane Highways
1720-3	Vehicle Inspection Installation
1720-4	Minor Portable Scale Site
1720-5	Major Portable Scale Site
1720-6	Small Shoulder Site
1720-7	Large Shoulder Site
1720-8	MOU Related to Vehicle Weighing and Equipment: Inspection Facilities on State Highways



## 1130.05 Cross Slopes

On tangent sections, the normal cross slopes of the traveled way are 2%.

If a longitudinal contiguous section of pavement is to be removed or is on a reconstructed alignment, or if a top course is to be placed over existing pavement, design the restored pavement cross slope to full design level criteria (see [Chapter 1230](#)).

The algebraic difference in cross slopes is an operational factor during a passing maneuver on a two-lane two-way roadway. Its influence increases when increased traffic volumes decrease the number and size of available passing opportunities.

A somewhat steeper cross slope may be desirable to facilitate pavement drainage in areas of intense rainfall, even though this might be less desirable from the operational point of view. In such areas, the design cross slopes may be increased to 2.5% with an algebraic difference of 5%.

For existing pavements, cross slopes within a range of 1% to 3% may remain if there are no operational or drainage concerns and, on a two-lane two-way roadway, the following conditions are met:

- The algebraic difference is not greater than 4% where the ADT is greater than 2000.
- The algebraic difference is not greater than 5% where the ADT is 2000 or less.
- The algebraic difference is not greater than 6% and the road is striped or signed for no passing.

For a two-lane two-way roadway, provide an algebraic difference to meet the appropriate conditions stated above except when facilitating drainage in areas of intense rainfall. When applying modified design level to a road with bituminous surface treatment (BST), the existing cross slope algebraic differences may remain.

To maintain or restore curb height, consider lowering the existing pavement level and improving cross slope by grinding before an asphalt overlay. The cross slope of the shoulder may be steepened to maximize curb height and minimize other related impacts. The shoulder may be up to 6% with a rollover between the traveled way and the shoulder of no more than 8% (see [Chapter 1230](#)).

## 1130.06 Sideslopes

### (1) Fill/Ditch Slopes

Foreslopes (fill slopes and ditch inslopes) and cut slopes are designed as shown in the Fill and Ditch Slope Selection Table in [Exhibit 1130-13](#) for modified design level main line roadway sections. After the foreslope has been determined, use the guidance in [Chapter 1600](#) to determine the need for a traffic barrier.

Where a crossroad or road approach has steep foreslopes, there is the possibility that an errant vehicle could become airborne. Therefore, flatten crossroad and road approach foreslopes to 6H:1V where feasible and at least to 4H:1V. Provide smooth transitions between the main line foreslopes and the crossroad or road approach foreslopes. Where possible, move the crossroad or road approach drainage away from the main line. This can locate the pipe outside the Design Clear Zone and reduce the length of pipe.

## (2) Cut Slopes

Existing stable backslopes (cut slopes) are to remain undisturbed unless disturbed by other work. When changes are planned to a cut slope, design them as shown in the Cut Slope Selection Table in [Exhibit 1130-13](#).

### 1130.07 Bike and Pedestrian

The Americans with Disabilities Act of 1990 (ADA) requires all pedestrian facilities located within public rights of way to be ADA-compliant. The Design Matrices in [Chapter 1100](#) identify that the modified design level applies to bike and pedestrian design elements on specific project types. For those projects, the following guidance applies to pedestrian facilities:

- Evaluate pedestrian facilities within the project limits for compliance with the ADA.
- Address pedestrian facilities that are altered in any way by the project.
- Evaluate and make ADA-compliant the curb ramps and crosswalks on projects that use hot mix asphalt or Portland cement concrete pavement overlays or inlays.
- Evaluate and make ADA-compliant the curb ramps and crosswalks on projects that alter pavement markings. Note: Lane restriping that does not involve modal changes (such as changing a shoulder to a bikeway) or lane configuration changes are not considered alterations.

For pedestrian facility design guidance, including jurisdictional responsibilities when city streets form part of the state highway system, see [Chapter 1510](#), and for the definition of alterations, see the [Glossary](#).

Bicycle elements are design exceptions on HMA or PCCP overlays or inlays on Interstate ramps or crossroads.

### 1130.08 Bridges

Design new and replacement bridges to full design level (see [Chapter 1140](#)) unless a corridor or project analysis justifies the use of modified design level lane and shoulder widths. Evaluate bridges to remain in place using Exhibits [1130-10](#) and [1130-11](#). Whenever possible, continue the roadway lane widths across the bridge and adjust the shoulder widths.

Consider joint use with other modes of transportation in lane and shoulder design (see Chapters [1410](#), [1430](#), [1510](#), [1515](#), and [1520](#)).

## 1130.09 Intersections

Except as provided below, design intersections to meet the guidance in Chapters [1300](#) and [1310](#).

### (1) Turn Radii

The intersection turn radii (or right-turn corners) are controlled by the design vehicle. [Exhibit 1130-7](#) is a guide for determining the design vehicle for modified design level. Perform a field review to determine intersection type, types of vehicles that use the intersection, and adequacy of the existing geometrics. Where the crossroad is a city street or county road, consider the city or county design criteria when selecting a design vehicle.

Design right-turn corners to meet the guidance of [Chapter 1310](#) using the design vehicle selected from [Exhibit 1130-7](#) or from the field review.

### (2) Angle

The allowable angle between any two respective legs is between 60° and 120° with 90° being desirable.

Intersection Type	Design Vehicle
Junction of Major Truck Routes	WB-67
Junction of State Routes	WB-40
Ramp Terminals	WB-40
Other Rural	SU-30 <sup>[1]</sup>
Urban Industrial	SU-30 <sup>[1]</sup>
Urban Commercial	P <sup>[1]</sup>
Residential	P <sup>[1]</sup>
<b>Note:</b>	
[1] Where the intersection is on a transit or school bus route, use the <u>CITY-BUS</u> design vehicle. (See <a href="#">Chapter 1430</a> for additional guidance on transit facilities and for the <u>CITY-BUS</u> turning path templates.)	

**Design Vehicles: Modified Design Level**  
*Exhibit 1130-7*

## 1130.10 Documentation

Refer to [Chapter 300](#) for design documentation requirements.

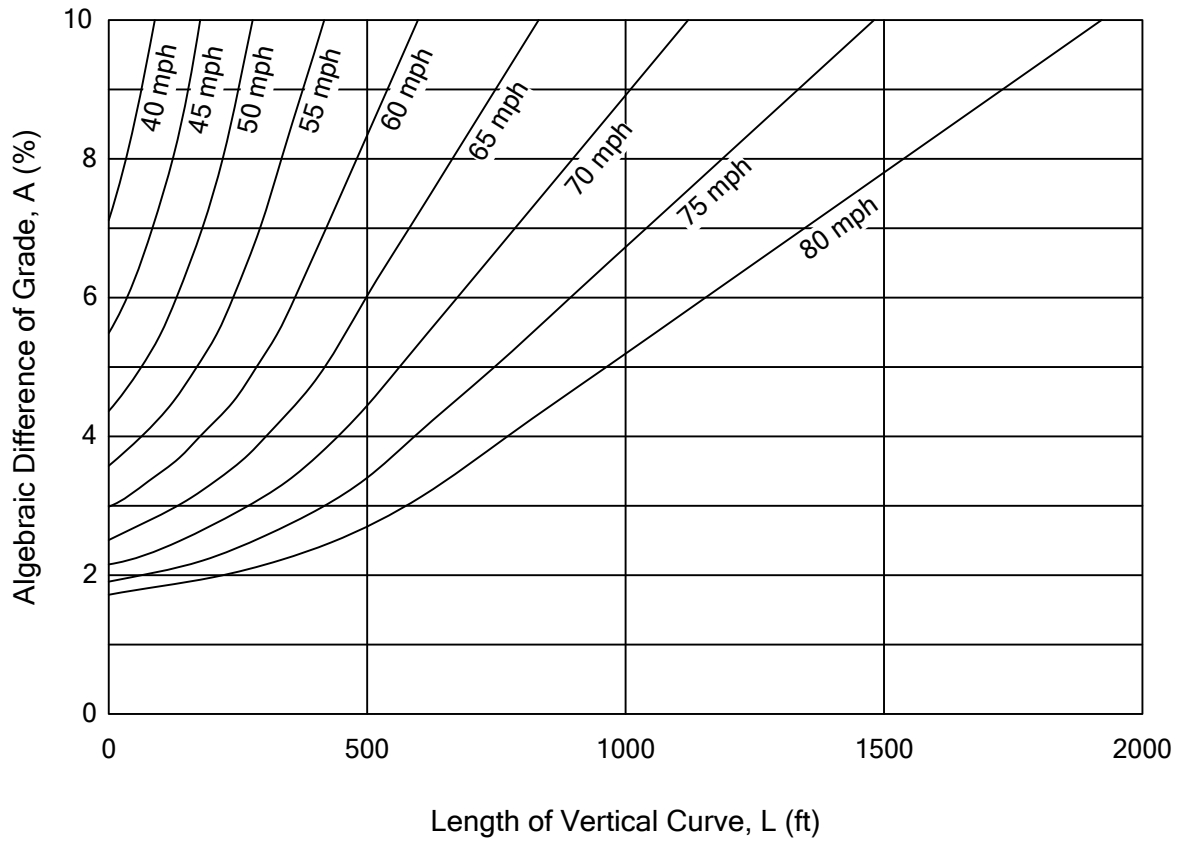

**Note:**

When the intersection of the algebraic difference of grade (A) with the length of vertical curve (L) is below the selected design speed line, modified design level criteria are met.

**Evaluation for Stopping Sight Distance for Crest Vertical Curves:  
Modified Design Level  
Exhibit 1130-8**

Guides for the coordination of the vertical and horizontal alignment are as follows:

- Balance curvature and grades. Using steep grades to achieve long tangents and flat curves or excessive curvature to achieve flat grades are both poor designs.
- Vertical curvature superimposed on horizontal curvature generally results in a more pleasing facility. Successive changes in profile not in combination with horizontal curvature may result in a series of dips not visible to the driver.
- Do not begin or end a horizontal curve at or near the top of a crest vertical curve. A driver may not recognize the beginning or ending of the horizontal curve, especially at night. An alignment where the horizontal curve leads the vertical curve and is longer than the vertical curve in both directions is desirable.
- To maintain drainage, design vertical and horizontal curves so that the flat profile of a vertical curve is not be located near the flat cross slope of the superelevation transition.
- Do not introduce a sharp horizontal curve at or near the low point of a pronounced sag vertical curve. The road ahead is foreshortened and any horizontal curve that is not flat assumes an undesirably distorted appearance. Further, vehicular speeds, particularly of trucks, often are high at the bottom of grades and erratic operation may result, especially at night.
- On two-lane roads, the need for passing sections (at frequent intervals and for an appreciable percentage of the length of the roadway) often supersedes the general desirability for the combination of horizontal and vertical alignment. Work toward long tangent sections to secure sufficient passing sight distance.
- On divided highways, consider variation in the width of medians and the use of independent alignments to derive the design and operational advantages of one-way roadways.
- Make the horizontal curvature and profile as flat as practicable at intersections where sight distance along both roads is important and vehicles may have to slow or stop.
- In residential areas, design the alignment to minimize nuisance factors to the neighborhood. Generally, a depressed facility makes a highway less visible and less noisy to adjacent residents. Minor horizontal adjustments can sometimes be made to increase the buffer zone between the highway and clusters of homes.
- Design the alignment to enhance attractive scenic views of the natural and constructed environment, such as rivers, rock formations, parks, and outstanding buildings.

When superelevation transitions fall within the limits of a vertical curve, plot profiles of the edges of pavement and check for smooth transitions.

### **1220.05 Airport Clearance**

Contact the airport authorities early for proposed highway construction or alteration in the vicinity of a public or military airport, so that advance planning and design work can proceed within the required Federal Aviation Administration (FAA) regulations (see [the \*Environmental Procedures Manual\*](#)).

### 1220.06 Railroad Crossings

When a highway crosses a railroad at grade, design the highway grade to prevent low-hung vehicles from damaging the rails or getting hung up on the tracks. [Exhibit 1220-3](#) gives guidance on designing highway grades at railroad crossings. For more information on railroad-highway crossings, see [Chapter 1350](#).

### 1220.07 Procedures

When the project modifies the vertical alignment, develop vertical alignment plans for inclusion in the Plans, Specifications, and Estimates (PS&E) to a scale suitable for showing vertical alignment for all proposed roadways, including ground line, grades, vertical curves, and superelevation. (See the [Plans Preparation Manual](#) for guidance.)

When justifying any modification to the vertical alignment, include the reasons for the change, alternatives addressed (if any) and why the selected alternative was chosen. When the profile is a result of new horizontal alignment, develop vertical and horizontal alignments together, and include the profile with the horizontal alignment justification.

### 1220.08 Documentation

For the list of documents required to be preserved in the Design Documentation Package and the Project File, see the Design Documentation Checklist:

[www.wsdot.wa.gov/design/projectdev/](http://www.wsdot.wa.gov/design/projectdev/)



- 1260.01 General
- 1260.02 References
- 1260.03 Stopping Sight Distance (Eye height – 3.5 ft, Object height – 2.0 ft)
- 1260.04 Passing Sight Distance (Eye height – 3.5 ft, Object height – 3.5 ft)
- 1260.05 Decision Sight Distance (Eye height – 3.5 ft, Object height – 2.0 ft)
- 1260.06 Documentation

## 1260.01 General

Sight distance allows the driver to assess developing situations and take actions appropriate for the conditions. Sight distance relies on drivers being aware of and paying attention to their surroundings and driving appropriately for conditions presented. For the purposes of design, sight distance is considered in terms of stopping sight distance, passing sight distance, and decision sight distance.

For additional information, see the following chapters:

Chapter	Subject
1250	Sight distance at railroad crossings
1310	Sight distance at intersections at grade
1320	Sight distance at roundabouts
1340	Sight distance at <u>driveways</u>
1515	Sight distance for shared-use paths

## 1260.02 References

### 1260.02(1) Design Guidance

*Manual on Uniform Traffic Control Devices for Streets and Highways*, USDOT, FHWA; as adopted and modified by [Chapter 468-95 WAC](#) “Manual on uniform traffic control devices for streets and highways” (MUTCD)

### 1260.02(2) Supporting Information

*A Policy on Geometric Design of Highways and Streets (Green Book)*, AASHTO

*Passing Sight Distance Criteria*, NCHRP 605

## 1260.03 Stopping Sight Distance (Eye height – 3.5 ft, Object height – 2.0 ft)

### 1260.03(1) Design Criteria

Stopping sight distance is provided when the sight distance available to a driver equals or exceeds the stopping distance for a passenger car traveling at the design speed.

Stopping distance for design is very conservatively calculated, with lower deceleration and slower perception reaction time than normally expected from the driver. Provide design stopping sight distance at all points on all highways and on all intersecting roadways in accordance with the design matrices, unless a design deviation is deemed appropriate.

**1260.03(1)(a) Stopping Sight Distance**

Stopping sight distance is the sum of two distances: the distance traveled during perception and reaction time and the distance to stop the vehicle. The perception and reaction distance used in design is the distance traveled in 2.5 seconds at the design speed.

The design stopping sight distance is calculated using the design speed and a constant deceleration rate of 11.2 feet/second<sup>2</sup>. For stopping sight distances on grades less than 3%, see [Exhibit 1260-1](#); for grades 3% or greater, see [Exhibit 1260-2](#).

**1260.03(1)(b) Design Stopping Sight Distance**

[Exhibit 1260-1](#) gives the design stopping sight distances for grades less than 3%, the minimum curve length for a 1% grade change to provide the stopping sight distance for a crest ( $K_c$ ) and sag ( $K_s$ ) vertical curve, and the minimum length of vertical curve for the design speed ( $VCL_m$ ). For stopping sight distances when the grade is 3% or greater, see [Exhibit 1260-2](#).

Design Speed (mph)	Design Stopping Sight Distance (ft)	$K_c$	$K_s$	$VCL_m$ (ft)
25	155	<u>12</u>	<u>26</u>	75
30	200	<u>19</u>	<u>37</u>	90
35	250	<u>29</u>	49	105
40	305	<u>44</u>	<u>64</u>	120
45	360	<u>61</u>	<u>79</u>	135
50	425	<u>84</u>	96	150
55	495	<u>114</u>	115	165
60	570	<u>151</u>	136	180
65	645	<u>193</u>	157	195
70	730	<u>247</u>	<u>181</u>	210
75	820	<u>312</u>	206	225
80	910	<u>384</u>	231	240

**Design Stopping Sight Distance***Exhibit 1260-1*

**1260.03(2) Effects of Grade**

The grade of the highway has an effect on the stopping sight distance. The stopping distance is increased on downgrades and decreased on upgrades. [Exhibit 1260-2](#) gives the stopping sight distances for grades of 3% and steeper. When evaluating sight distance with a changing grade, use the grade for which the longest sight distance is needed.

Design Speed (mph)	Stopping Sight Distance (ft)					
	Downgrade			Upgrade		
	-3%	-6%	-9%	3%	6%	9%
25	158	165	173	147	143	140
30	205	215	227	<u>200</u>	184	179
35	<u>257</u>	271	<u>287</u>	237	229	222
40	315	333	354	289	278	269
45	378	<u>400</u>	<u>427</u>	<u>344</u>	331	320
50	<u>446</u>	474	<u>507</u>	405	<u>388</u>	375
55	520	553	<u>593</u>	<u>469</u>	450	433
60	<u>598</u>	638	<u>686</u>	<u>538</u>	515	495
65	<u>682</u>	<u>728</u>	<u>785</u>	612	<u>584</u>	561
70	<u>771</u>	<u>825</u>	<u>891</u>	690	658	631
75	<u>866</u>	<u>927</u>	<u>1,003</u>	<u>772</u>	736	<u>704</u>
80	<u>965</u>	<u>1,035</u>	<u>1,121</u>	<u>859</u>	<u>817</u>	782

**Design Stopping Sight Distance on Grades***Exhibit 1260-2*

For stopping sight distances on grades between those listed, interpolate between the values given or use the equation in [Exhibit 1260-3](#).

$$S = 1.47V(2.5) + \frac{V^2}{30 \left[ 0.347826 \pm \left( \frac{G}{100} \right) \right]}$$

**Where:**  
 $S$  = Stopping sight distance on grade (ft)  
 $V$  = Design speed (mph)  
 $G$  = Grade (%)

**Stopping Sight Distance on Grades***Exhibit 1260-3***1260.03(3) Crest Vertical Curves**

When evaluating an existing roadway, refer to [1260.03\(7\)](#).

Use [Exhibit 1260-4](#) or the equations in [Exhibit 1260-5](#) to find the minimum crest vertical curve length to provide stopping sight distance when given the algebraic difference in grades. [Exhibit 1260-4](#) does not show the sight distance greater than the length of curve equation.

When the sight distance is greater than the length of curve and the length of curve is critical, the  $S > L$  equation given in Exhibit 1260-5 shall be used to find the minimum curve length.

When a new crest vertical curve is built or an existing one is rebuilt with grades less than 3%, provide design stopping sight distance from Exhibit 1260-1. For grades 3% or greater, provide stopping sight distance from 1260.03(2).

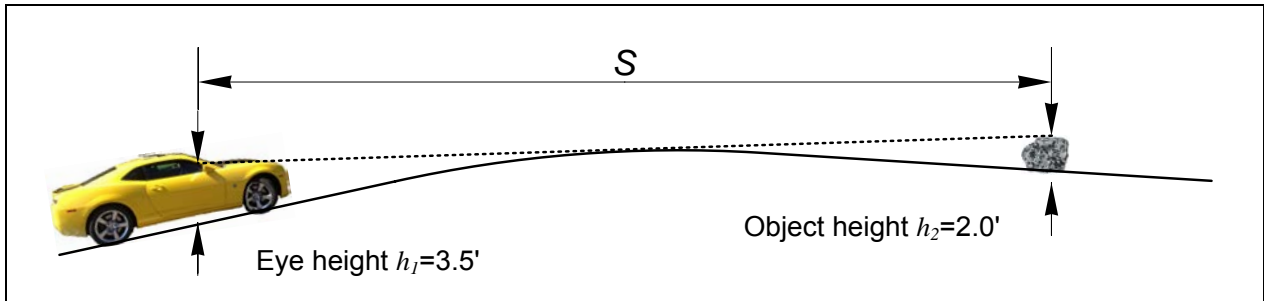

The minimum length can also be determined by multiplying the algebraic difference in grades by the  $K_C$  value from Exhibit 1260-1 ( $L = K_C * A$ ). Both the exhibit and the equation give approximately the same length of curve. Neither use the  $S > L$  equation.

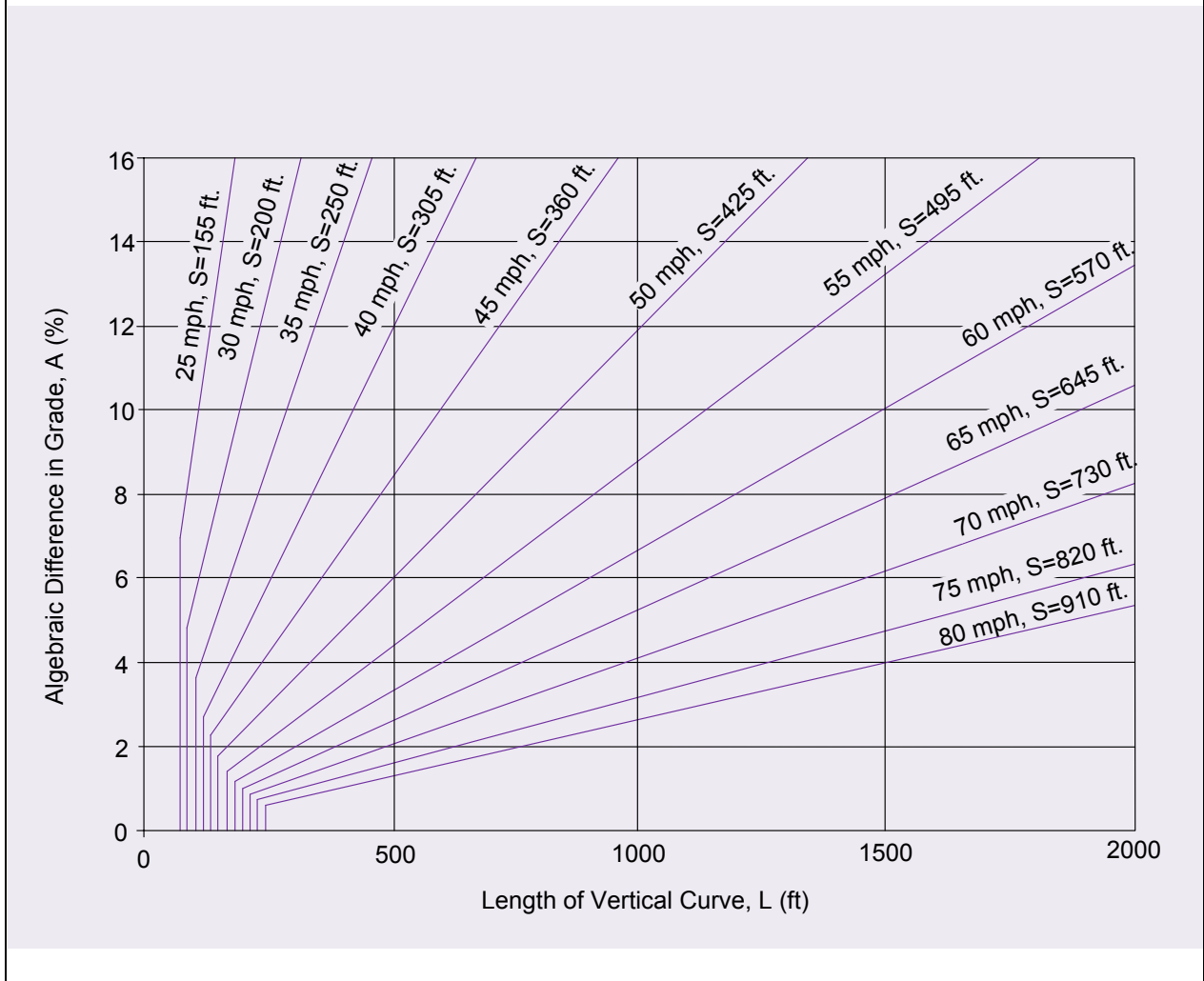

Stopping Sight Distance: Crest Vertical Curves  
Exhibit 1260-4

<b>When <math>S &gt; L</math></b>	
$L = 2S - \frac{2158}{A}$	$S = \frac{L + \left(\frac{2158}{A}\right)}{2}$
<b>When <math>S &lt; L</math></b>	
$L = \frac{AS^2}{2158}$	$S = \sqrt{\frac{2158L}{A}}$
<p><b>Where:</b>  <math>L</math> = Length of vertical curve (ft)  <math>S</math> = Sight distance (ft)  <math>A</math> = Algebraic difference in grades (%)</p>	

### Sight Distance: Crest Vertical Curve

*Exhibit 1260-5*

#### 1260.03(4) Sag Vertical Curves

When evaluating an existing roadway, refer to [1260.03\(7\)](#).

Sight distance is not restricted by sag vertical curves during the hours of daylight. Therefore, headlight sight distance is used for the sight distance design criteria at sag vertical curves. In some cases, a lesser length may be allowed. For guidance, see [Chapter 1220](#).

Refer to [Exhibit 1260-6](#) or the equations in [Exhibit 1260-7](#) to find the minimum length for a sag vertical curve to provide the headlight stopping sight distance when given the algebraic difference in grades. The value for S is shown as the distance between the vehicle and the point where a 1-degree angle upward of the headlight beam intersects with the roadway.

The sight distance greater than the length of curve equation is not used in [Exhibit 1260-6](#). When the sight distance is greater than the length of curve and the length of curve is critical, the  $S > L$  equation given in [Exhibit 1260-7](#) shall be used to find the minimum length of curve.

When a new sag vertical curve is built or an existing one is rebuilt with grades less than 3%, provide design stopping sight distance from [Exhibit 1260-1](#). For grades 3% or greater, provide stopping sight distance from [1260.03\(2\)](#).

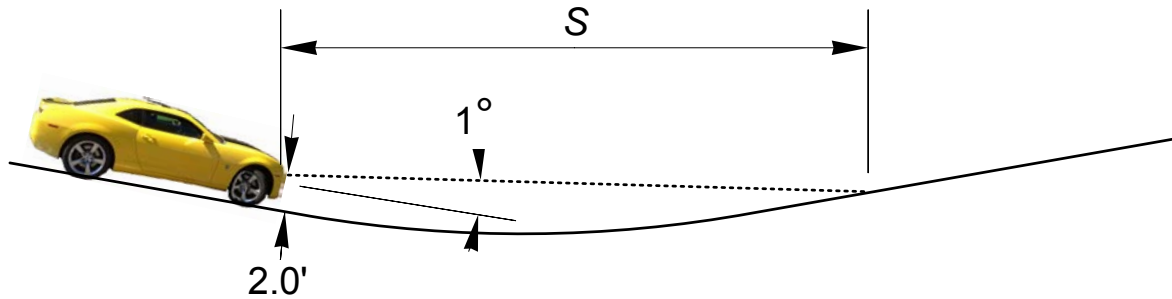

The minimum length can also be determined by multiplying the algebraic difference in grades by the  $K_S$  value from [Exhibit 1260-1](#) ( $L=K_S*A$ ). Both the exhibit and equation give approximately the same length of curve. Neither use the  $S>L$  equation.

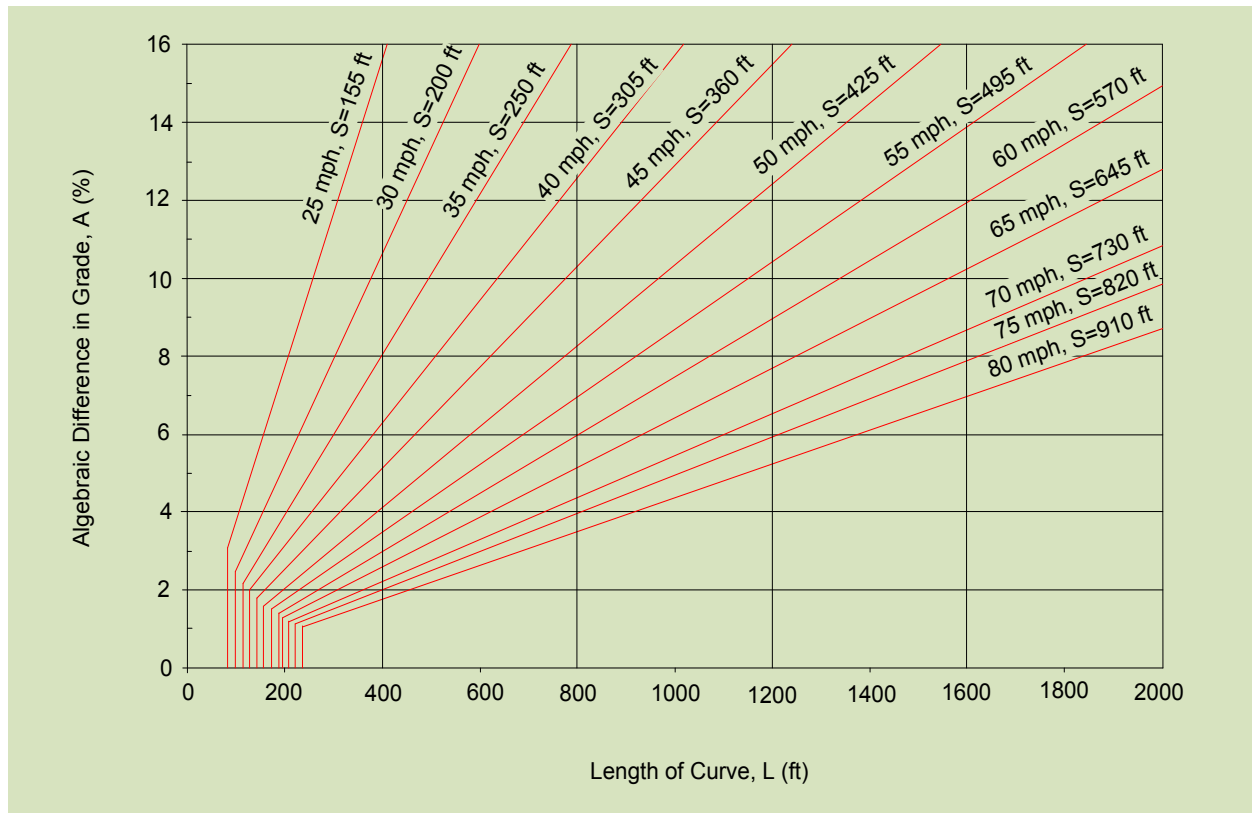

**Stopping Sight Distance for Sag Vertical Curves**  
 Exhibit 1260-6

<b>When <math>S &gt; L</math></b>	
$L = 2S - \frac{400 + 3.5S}{A}$	$S = \frac{LA + 400}{2A - 3.5}$
<b>When <math>S &lt; L</math></b>	
$L = \frac{AS^2}{400 + 3.5S}$	$S = \frac{3.5L \pm \sqrt{(3.5L)^2 + 1600AL}}{2A}$
<b>Where:</b>	
$L$ = Curve length (ft)	
$A$ = Algebraic grade difference (%)	
$S$ = Sight distance (ft)	
<b>Note:</b>	
Values for $A$ less than 1.75 are within the 1-degree diverge of the headlight beam and therefore do not need to be evaluated for SSD on sag curves.	

### Sight Distance: Sag Vertical Curve

*Exhibit 1260-7*

#### 1260.03(5) Horizontal Curves

When evaluating an existing roadway, see [1260.03\(7\)](#).

Use [Exhibit 1260-8](#) or the equation in [Exhibit 1260-9](#) to check stopping sight distance where sightline obstructions are on the inside of a curve. A stopping sight distance sightline obstruction is any roadside object within the horizontal sightline offset ( $M$ ) distance (such as median barrier, guardrail, bridges, walls, cut slopes, buildings or wooded areas), 2.0 feet or greater above the roadway surface at the centerline of the lane on the inside of the curve ( $h_0$ ). [Exhibit 1260-8](#) and the equation in [Exhibit 1260-9](#) are for use when the length of curve is greater than the sight distance and the sight restriction is more than half the sight distance from the end of the curve. Where the length of curve is less than the stopping sight distance or the sight restriction is near either end of the curve, the desired sight distance may be available with a lesser  $M$  distance. When this occurs, the sight distance can be checked graphically.



A sightline obstruction is any roadside object within the horizontal sightline offset ( $M$ ) distance, 2.0 feet or greater above the roadway surface at the centerline of the lane on the inside of the curve.

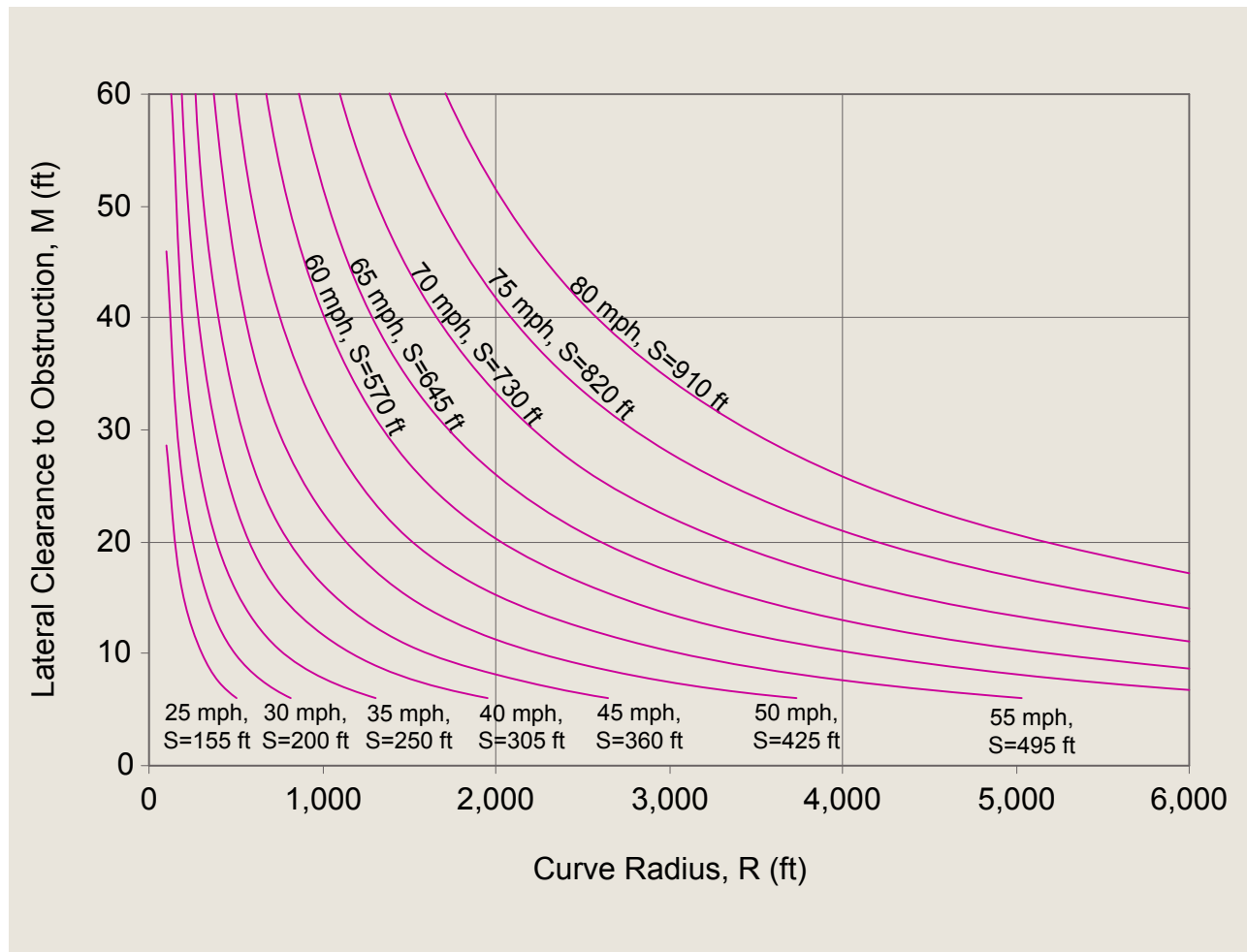
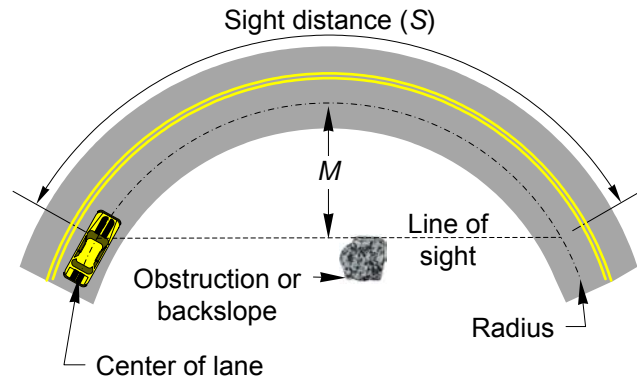

**Horizontal Stopping Sight Distance**  
Exhibit 1260-8



When the road grade is less than 3%, provide design stopping sight distance from [Exhibit 1260-1](#). When the grade is 3% or greater, provide stopping sight distance from [1260.03\(2\)](#).

Roadside objects with a height ( $h_o$ ) between 2.0 feet and 2.75 feet might not be a stopping sight distance sightline obstruction. Objects with an  $h_o$  between 2.0 feet and 2.75 feet can be checked graphically to determine whether they are stopping sight distance sightline obstructions.

Where a sightline obstruction exists and site characteristics preclude design modifications to meet criteria, consult with the region Traffic Engineer and Assistant State Design Engineer for a determination of appropriate action.

$$M = R \left[ 1 - \cos \left( \frac{28.65S}{R} \right) \right] \quad S = \frac{R}{28.65} \left[ \cos^{-1} \left( \frac{R-M}{R} \right) \right]$$

**Where:**

$M$  = Horizontal sightline offset measured from the centerline of the inside lane of the curve to the sightline obstruction (ft)

$R$  = Radius of the curve (ft)

$S$  = Sight distance (ft)

**Sight Distance: Horizontal Curves**

*Exhibit 1260-9*

**1260.03(6) Overlapping Horizontal and Vertical Curves**

Vertical curves on a horizontal curve have an effect on which roadside objects are sightline obstructions. Crest vertical curves make roadside objects *more* likely to become sightline obstructions. Sag vertical curves make roadside objects *less* likely to be sightline obstructions.

[Exhibit 1260-10](#) can be used to determine the sight distance for crest vertical curves on horizontal curves with:

- Sightline obstructions inside the  $M$  distance.
- Sightline obstruction height ( $h_o$ ) of 2.0 feet or less.

For other locations, the sight distance can be checked graphically.

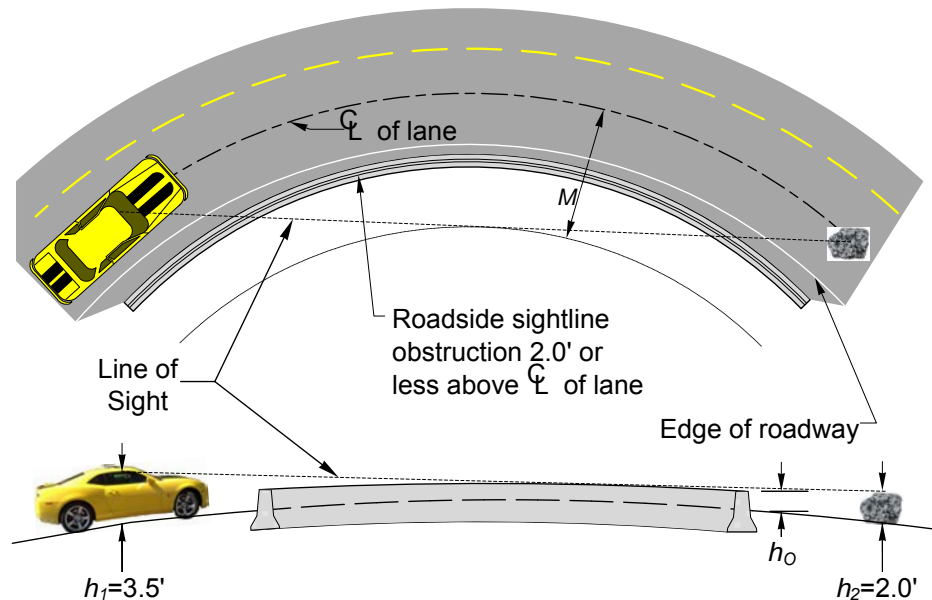

The following equation may be used to determine the sight distance for roadside sightline obstructions inside the horizontal sightline offset ( $M$ ) distance (see [Exhibit 1260-9](#)) with a height of 2.0 feet or less above the centerline of the lane on the inside of the curve on overlapping horizontal and crest vertical curves.

$$S = \sqrt{\frac{100L[\sqrt{2(h_1 - h_0)} + \sqrt{2(h_2 - h_0)}]^2}{A}}$$

**Where:**

$L$  = Length of vertical curve (ft)

$S$  = Sight distance (ft)

$A$  = Algebraic difference in grades (%)

$h_1$  = Eye height (3.5 ft)

$h_2$  = Object height (2.0 ft)

$h_0$  = Height of roadside sightline obstructions above the centerline of the inside curve lane (2.0 ft or less)

**Note:**

The above equation cannot be used for sightline obstruction height ( $h_0$ ) more than 2.0 ft above the centerline of the lane on the inside of the curve. The available sight distance must be checked graphically for these sightline obstructions.

### Sight Distance: Overlapping Horizontal and Crest Vertical Curves

*Exhibit 1260-10*

#### 1260.03(7) Existing Stopping Sight Distance

Existing stopping sight distance values from [Exhibit 1260-11](#) may be used at all horizontal and vertical curves where all of the following are met at the curve:

- There is no identified collision trend.
- The existing vertical and horizontal alignment is retained.
- The existing roadway pavement is not reconstructed.
- The roadway will not be widened, except for minor shoulder widening requiring no work past the bottom of the ditch.
- The sightline obstruction is existing.
- Roadside improvements to sight distance are within existing right of way.

*Crest Vertical Curves* – The minimum length of an existing crest vertical curve may be found using the equations in [Exhibit 1260-5](#) or using the  $K_C$  values from [Exhibit 1260-11](#).

*Sag Vertical Curves* – The minimum length of an existing sag vertical curve may be found using the equations in [Exhibit 1260-7](#) or using the  $K_S$  values from [Exhibit 1260-11](#). In some cases, when continuous illumination is provided, a lesser length may be allowed. For guidance, see [Chapter 1220](#).

Design Speed (mph)	Existing Stopping Sight Distance (ft)	$K_c$	$K_s$
20	115	6	16
25	145	10	23
30	180	15	31
35	220	22	41
40	260	31	52
45	305	43	63
50	350	57	75
55	400	74	89
60	455	96	104
65	495	114	115
70	540	135	127
75	585	159	140
80	630	184	152

**Existing Stopping Sight Distance**  
*Exhibit 1260-11*

### **1260.04 Passing Sight Distance (Eye height – 3.5 ft, Object height – 3.5 ft)**

#### **1260.04(1) Design Criteria**

Minimum passing sight distance is the distance (on a two-lane highway) used for a driver to execute a normal passing maneuver based on design conditions and design speed.

The potential for passing maneuver conflicts is ultimately determined by the judgments of the driver and the conditions present at the time of the maneuver. [Exhibit 1260-12](#) gives the passing sight distances for various design speeds.

Design Speed (mph)	Minimum Passing Sight Distance (ft)
20	<u>400</u>
25	<u>450</u>
30	<u>500</u>
35	<u>550</u>
40	<u>600</u>
45	<u>700</u>
50	<u>800</u>
55	<u>900</u>
60	<u>1000</u>
65	<u>1100</u>
70	<u>1200</u>
75	<u>1300</u>
80	<u>1400</u>

**Passing Sight Distance**  
*Exhibit 1260-12*

On two-lane two-way highways, provide passing opportunities to meet traffic volume demands. This can be accomplished with roadway sections that provide passing sight distance or by adding passing lanes at locations that would provide the greatest benefit to passing (see [Chapter 1270](#)).

In the design stage, passing sight distance can be provided by adjusting the alignment either vertically or horizontally to increase passing opportunities.

These considerations also apply to multilane highways where staged construction includes a two-lane two-way operation as an initial stage. Whether auxiliary lanes are provided, however, depends on the time lag proposed between the initial stage and the final stage of construction.

### 1260.04(2) Passing Sight Distance Vertical Curves

[Exhibit 1260-14](#) gives the length of crest vertical curve used to provide passing sight distance for two lane highways. The distance from [Exhibit 1260-12](#) and the equations in [Exhibit 1260-13](#) may also be used to determine the minimum length of vertical curve to meet the passing sight distance criteria.

Sag vertical curves are not a restriction to passing sight distance.

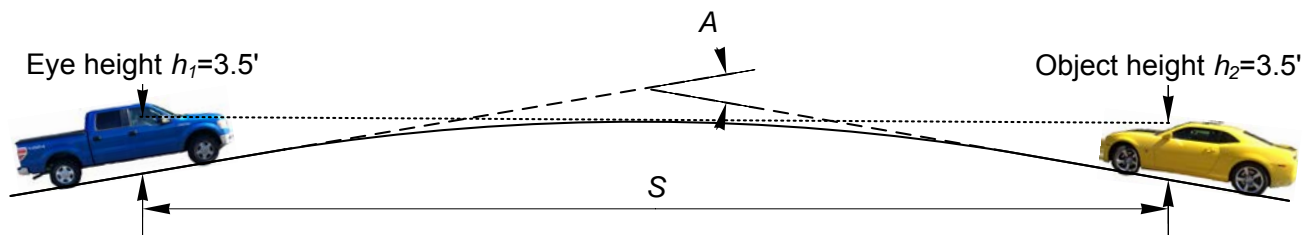

<b>When <math>S &gt; L</math></b>	
$L = 2S - \frac{2800}{A}$	$S = \frac{L}{2} + \frac{1400}{A}$
<b>When <math>S &lt; L</math></b>	
$L = \frac{AS^2}{2800}$	$S = \sqrt{\frac{2800L}{A}}$
<b>Where:</b>	
$L$ = Length of vertical curve (ft)	
$A$ = Algebraic grade difference (%)	
$S$ = Sight distance (ft)	

**Passing Sight Distance: Crest Vertical Curve Calculations**  
*Exhibit 1260-13*

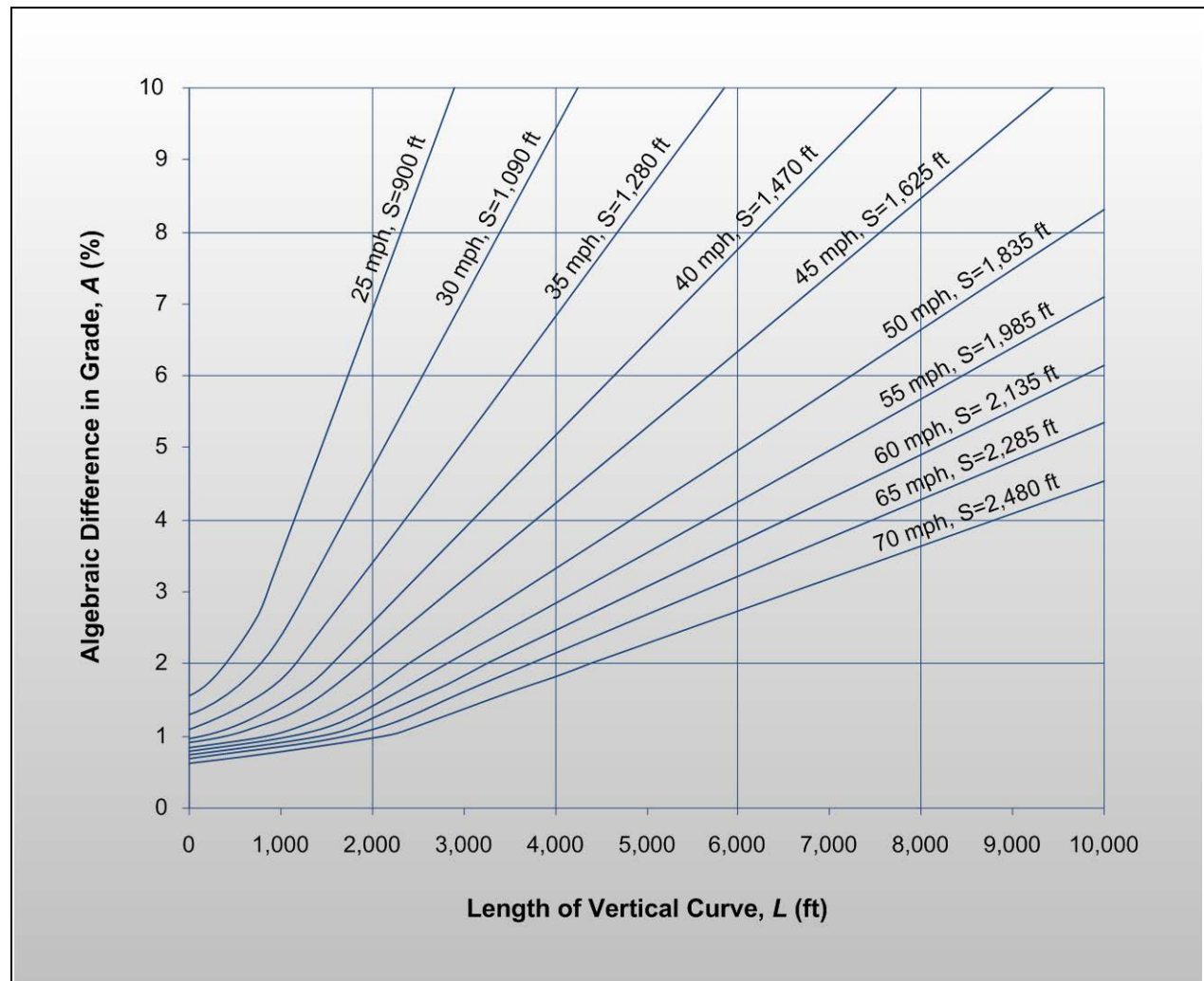

### **Passing Sight Distance: Crest Vertical Curves**

*Exhibit 1260-14*

#### **1260.04(3) Passing Sight Distance Horizontal Curves**

Passing sight distance can be restricted on the inside of a horizontal curve by sightline obstructions that are 3.5 feet or more above the roadway surface. Use the distance from [Exhibit 1260-12](#) and the equation in [Exhibit 1260-9](#) to determine whether the object is close enough to the roadway to be a restriction to passing sight distance. The equation assumes that the curve length is greater than the sight distance. Where the curve length is less than the sight distance, the desired sight distance may be available with a lesser sightline offset ( $M$ ) distance.

### 1260.05 Decision Sight Distance (Eye height – 3.5 ft, Object height – 2.0 ft)

Decision sight distance values are greater than stopping sight distance values because they give the driver an additional margin for error and afford sufficient length to maneuver at the same or reduced speed rather than to just stop.

Consider decision sight distances (see [Exhibit 1260-15](#)) at locations where there is high likelihood for driver error in information reception, decision making, or control actions. If site characteristics and budget allow, locate these highway features where decision sight distance can be provided. If this is not practicable, use suitable traffic control devices and positive guidance to give advanced warning of the conditions.

Design Speed (mph)	Decision Sight Distance for Maneuvers (ft)				
	A	B	C	D	E
30	220	490	450	535	620
35	275	590	525	625	720
40	330	690	600	715	825
45	395	800	675	800	930
50	465	910	750	890	1030
55	535	1030	865	980	1135
60	610	1150	990	1125	1280
65	695	1275	1050	1220	1365
70	780	1410	1105	1275	1445
75	875	1545	1180	1365	1545
80	970	1685	1260	1455	1650

#### Decision Sight Distance

##### *Exhibit 1260-15*

The maneuvers in [Exhibit 1260-15](#) are as follows:

A = Rural stop

D = Suburban speed/path/direction change

B = Urban stop

E = Urban speed/path/direction change

C = Rural speed/path/direction change

Use the equations in Exhibits [1260-5](#), [1260-7](#), and [1260-9](#) to determine the available decision sight distance for crest vertical curves, sag vertical curves, and horizontal curves.

### 1260.06 Documentation

It is recognized that some designs do not allow all criteria and guidelines to be followed as outlined in this chapter.

Refer to [Chapter 300](#) for design documentation requirements.

- 1300.01 General
- 1300.02 References
- 1300.03 Intersection Control Objectives
- 1300.04 Common Types of Intersection Control
- 1300.05 Design Vehicle Selection
- 1300.06 Procedures
- 1300.07 Documentation

### 1300.01 General

It is WSDOT practice to analyze potential intersection solutions at all intersection improvement locations in accordance with *Business Practices for Moving Washington*, and strive to provide the optimum solution within available limited resources. The analysis may be done for individual intersections, or on a corridor basis. This chapter provides guidance on preliminary intersection analysis and selection of control type. Intersection design is completed using [Chapter 1310](#) for the geometrics of intersections, [Chapter 1320](#) for roundabouts, and [Chapter 1330](#) for traffic signals.

Intersections are an important part of highway design. They comprise only a small percentage of the overall highway system miles, yet they account for a high percentage of reported collisions.

Traffic and driver characteristics, bicycle and pedestrian needs, physical features, and economics are considered in selecting traffic control that facilitates efficient multimodal traffic flow through intersections. Signs, signals, channelization, and physical geometric layout are the major tools used to establish intersection control.

Typically, potential project locations will have been identified through the safety improvement priority programming process, necessity for a mobility project for congestion improvement, commercial development, or other improvement project.

An Intersection Control Analysis (ICA) should be completed as early in the design development process as feasible. ***The level of effort of the ICA should be scalable to the project***; for example, evaluation of adding a turn lane to an existing intersection control may take less effort than evaluating new intersection control. This may occur during planning or corridor studies, but should not be initiated later than the scoping stage of a project. Data-based knowledge and scientific evaluation provides the basis for a rational engineered improvement.

When analysis determines that an at-grade intersection cannot provide adequate service, consider a grade separation, or partial or full interchange. Evaluate grade separation alternatives for intersections on rural expressways, both National Highway System (NHS) and non-NHS. The ramp terminal intersections are subject to the analysis requirements of this chapter. (See [Chapters 1360](#) and [550](#) for further guidance.)

For additional information, see the following chapters:

Chapter	Subject
320	Traffic Analysis
530	Limited access control
540	Managed access control
550	Interchange Justification Report
1310	Intersections
1320	Roundabouts
1330	Traffic signals
1360	Interchanges
1510	Pedestrian facilities
1515	Shared-use paths
1520	Bicycle facilities

## 1300.02 References

### 1300.02(1) Federal/State Laws, Codes, and Policies

[Revised Code of Washington \(RCW\) 46.61](#), Rules of the road

[Washington Administrative Code \(WAC\) 468-52](#), Highway access management – access control classification system and standards

Intersection Control/Modification Process, Highway Safety Executive Committee (HSEC) Policy Paper, April 2012, WSDOT

[Secretary's Executive Order: E 1082](#), Business Practices for Moving Washington, August 2012, WSDOT

### 1300.02(2) Design Guidance

*A Policy on Geometric Design of Highways and Streets* (Green Book), AASHTO

*Highway Capacity Manual* (HCM), latest edition, Transportation Research Board, National Research Council

[Local Agency Guidelines](#) (LAG), M 36-63, WSDOT

*Manual on Uniform Traffic Control Devices for Streets and Highways*, USDOT, FHWA; as adopted and modified by [Chapter 468-95 WAC](#) “Manual on uniform traffic control devices for streets and highways” (MUTCD)

*Standard Plans for Road, Bridge, and Municipal Construction* (*Standard Plans*), M 21-01, WSDOT

### 1300.02(3) Supporting Information

*Highway Safety Manual* (HSM), AASHTO

*Roundabouts: An Informational Guide*, FHWA-RD-00-067, USDOT, FHWA

*Roundabouts: An Informational Guide*, Second Edition, NCHRP Report 672, Transportation Research Board, 2010



A Review of the Signalized Intersections: Informational Guide. FHWA-HRT-04-092, USDOT, FHWA, APRIL 2004

☞ [www.fhwa.dot.gov/publications/research/safety/04092/](http://www.fhwa.dot.gov/publications/research/safety/04092/)

Buckholz, “Choosing Intersection Control.” IMSA Journal, Nov/Dec 2002.

☞ [www.imsasafety.org/journal/nd02/buckholz.pdf](http://www.imsasafety.org/journal/nd02/buckholz.pdf)

Kuciemba, S. R., and J. A. Cirillo. Safety Effectiveness of Highway Design Features, Volume V: Intersections, Report No. FHWA-RD-91-048, Federal Highway Administration, November 1992.

Luttrell, Greg, Eugene R. Russell, and Margaret Rys. “A Comparison of a Roundabout to Two-way Stop Controlled Intersections with Low and High Traffic Volumes,” Kansas State University

NCHRP Report 500, Guidance for Implementation of the AASHTO Strategic Highway Safety Plan, Volume 5: A Guide for Addressing Unsignalized Intersection Collisions, Transportation Research Board, 2003

☞ [http://onlinepubs.trb.org/onlinepubs/nchrp/nchrp\\_rpt\\_500v5.pdf](http://onlinepubs.trb.org/onlinepubs/nchrp/nchrp_rpt_500v5.pdf)

NCHRP Report 500, Guidance for Implementation of the AASHTO Strategic Highway Safety Plan Volume 12: A Guide for Reducing Collisions at Signalized Intersections, Transportation Research Board, 2004

☞ [onlinepubs.trb.org/onlinepubs/nchrp/nchrp\\_rpt\\_500v12.pdf](http://onlinepubs.trb.org/onlinepubs/nchrp/nchrp_rpt_500v12.pdf)

Synthesis of the Median U-Turn Intersection Treatment, Safety, and Operational Benefits, FHWA-HRT-07-033, USDOT, FHWA

### 1300.03 Intersection Control Objectives

Intersections make up the majority of potential transportation conflict areas. Good intersection design is used for reasonably safe and efficient travel by auto, truck, bus, motorcycle, pedestrian, and other travel modes. Coordinate design with existing adjacent intersections.

Intersection control choice requires consideration of all potential users of the facility, including drivers of motorcycles, passenger cars, heavy vehicles of different classifications, public transit, and bicyclists and pedestrians.

Drivers have varying skills and abilities. Elderly drivers in particular are subject to increased reaction time, decreased ability to perceive visual cues, and decreased head and neck flexibility. While there is evidence that older drivers are aware of some decline in their abilities and therefore adjust their driving patterns, some of their changes can lead to more travel on local roads and thus more exposure to intersection conflict. *These considerations have been factored into the guidance for intersection design.*

Meeting the needs of one user group can result in compromising service to others. The selection process balances these competing needs, resulting in appropriate levels of operation for all users.

With consideration for sustainable transportation practices, four basic elements should be well thought out in intersection design:

<b>Intersection Design Elements</b>	
<b>Human Factors</b>	
➤ Driving habits	➤ Conformance to natural paths of movement
➤ Ability of drivers to make decisions	➤ Pedestrian use and habits
➤ Driver expectancy	➤ Bicycle traffic use and habits
➤ Decision and reaction time	➤ Demand for alternative mode choices
<b>Traffic Considerations</b>	
➤ Classification of each intersecting roadway	➤ Vehicle speeds
➤ Design and actual capacities	➤ Transit involvement
➤ Design-hour turning movements	➤ Crash experience
➤ Size and operating characteristics of vehicle	➤ Bicycle movements
➤ Variety of movements (diverging/merging/weaving/crossing)	➤ Pedestrian movements
<b>Physical Elements</b>	
➤ Character and use of abutting property	➤ Traffic control devices
➤ Vertical alignments at the intersection	➤ Illumination
➤ Sight distance	➤ Roadside design features
➤ Angle of the intersection	➤ Environmental factors
➤ Conflict area	➤ Crosswalks
➤ Speed-change lanes	➤ Driveways
➤ Geometric design features	➤ Access management treatments
<b>Economic Factors</b>	
➤ Cost of improvements, maintenance, and life cycle costs	
➤ Effects of controlling right of way on abutting properties where channelization restricts or prohibits vehicular movements	
➤ Energy consumption	

## 1300.04 Common Types of Intersection Control

### 1300.04(1) Uncontrolled Intersections

- Uncontrolled intersections do not have signing, and the normal right of way rule ([RCW 46.61.180](#)) applies.
- Most uncontrolled intersections are found on local roads and streets where the volumes of the intersecting roadways are low and roughly equal, speeds are low, and there is little to no collision history.
- Uncontrolled intersections are generally not appropriate for intersections with state routes.



### 1300.04(2) Yield Control

- Intersections with yield control assign right of way without requiring a stop.
- It is mainly used at roundabouts, ramps, and wye (Y) intersections.

Refer to the [MUTCD](#) for information on the locations where yield control may be appropriate.

### 1300.04(3) Two-Way Stop Control

- Intersections with two-way stop control are a common, low-cost control, which require the traffic on the minor roadway to stop before entering the major roadway. It is used where application of the normal right of way rule ([RCW 46.61.180](#)) is not appropriate for certain approaches at the intersection.
- Where U-turn opportunities exist within a corridor, consider limiting access at two-way stops to “right-in, right-out only.”



### 1300.04(4) Multi-Way Stop Control

Intersections with multi-way stop control:

- Normally require all traffic to stop before entering the intersection.
- Increase traffic delays, fuel consumption, and air pollution.
- Are most effectively used on low-speed facilities with approximately equal volumes on all legs and total entering volumes not exceeding 1,400 vehicles during the peak hour.
- Are often used as an interim measure when a traffic signal is warranted and has been determined to be the best solution, but has yet to be installed.



Guidance for consideration of the application of multi-way stop control is provided in the [MUTCD](#).

On multilane facilities, they present more operational issues than on two-lane two-way facilities and are not recommended on multilane state routes. Multi-way stop control is less desirable at intersections with very unbalanced directional traffic due to the delay introduced on the major-volume leg.

### 1300.04(5) Roundabouts

Roundabouts are circular to near circular at-grade intersections. Properly designed, located, and maintained roundabouts are an effective intersection type that normally offer the following:

- Fewer conflict points.
- Lower speeds.
- An alternative for areas where wrong-way driving is a concern.
- Reduced fatal- and severe-injury collisions.
- Reduced traffic delays.
- Traffic-calming.
- More capacity than a two-way or all-way stop.
- More consistent delay relative to other intersection treatments.
- The ability to serve high turning volumes.
- Improved operations where space for queuing is limited.



- At ramp terminals where left-turn volumes are high, improved capacity without widening the structure.
- Facilitation of U-turn movements.

Some disadvantages of roundabouts include the following:

- Collisions may temporarily increase due to lack of driver education.
- As queues develop, drivers may accept smaller gaps, which may increase collisions.
- Right of way requirements.
- Work zone traffic control restrictions within the roundabout for maintenance operations.
- No preemption for emergency vehicle passage.

Roundabouts are site-specific solutions. There are no warranting conditions; each is justified on its own merits as the most appropriate choice. However, there is modeling software for roundabouts, making the comparison of intersection control types and justification possible from an operations perspective.

### 1300.04(6) **Traffic Control Signals**

Properly designed, located, operated, and maintained traffic control signals may offer the following:

- Allow for the orderly movement of traffic.
- Increase the traffic-handling capacity of the intersection.
- Reduce the frequency of severe collisions, especially right-angle collisions.
- Can be coordinated to provide for continuous or nearly continuous movement of traffic at a definite speed along a given corridor under favorable conditions.
- Can be used to interrupt heavy traffic at intervals to permit other traffic, vehicular or pedestrian, to cross.
- Can be preempted to allow emergency vehicle passage.

Traffic control signals are not the solution for all intersection traffic concerns. Indiscriminate installation of signals can adversely affect the safety and efficiency of vehicle, bicycle, and pedestrian traffic.

As a result, installation of a traffic control signal must meet specific “warrants,” which are found in the [MUTCD](#). A signal warrant is a minimum condition in which a signal may be installed. Satisfying a signal warrant does not mandate the installation of a traffic signal; it only indicates that an engineering study, as described in this chapter, is needed to determine whether the signal is an appropriate traffic control solution.

Some collisions are usually not correctable with the installation of a traffic signal; in fact, the installation of a signal often increases rear-end collisions. These types of collisions are only used to satisfy the collision warrant in special circumstances. If they are used, include an explanation of the conditions that support using them to satisfy the crash experience warrant.

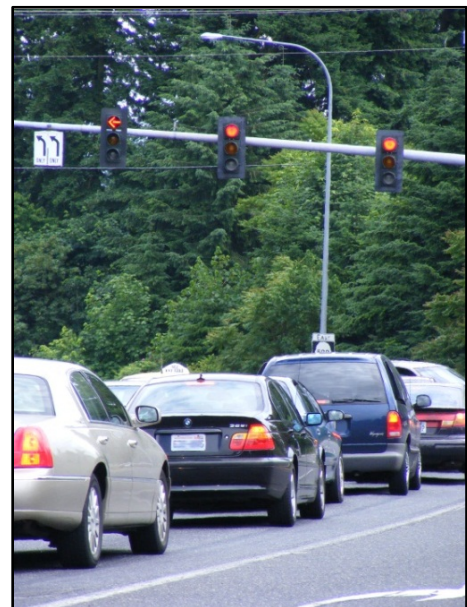

State statutes ([RCW 46.61.085](#)) require WSDOT approval for the design and location of all conventional traffic signals and for some types of beacons located on city streets forming parts of state highways. The Traffic Signal Permit (DOT Form 242-014 EF) is the formal record of the department's approval of the installation and type of signal. For traffic signal permit guidance, see [Chapter 1330](#).

### 1300.04(7) Unconventional Intersections

A number of unconventional intersections have been developed to reduce the delay to through traffic, the number of conflict points, and the number of signal phases for signalized intersections. Like any intersection control solution, if they are considered, they present certain operational issues that must be addressed during the selection process to determine their viability prior to proceeding with the actual design.

Unconventional intersections work mainly by rerouting U and left turns, and/or separating movements. Unconventional intersections include:

Median U-turn	Split intersection
Jug handle	Quadrant roadway intersection
Bowtie	Single quadrant interchange
Superstreet	Echelon
Continuous flow intersection	Center turn overpass
Continuous green tee (T)	

Disadvantages, depending on the type selected, may include higher construction costs, driver education, longer left-turn travel distance, circuitous access to adjacent property, and less direct pedestrian crossing.

For additional information on these intersection design solutions, see the Applied Technology and Traffic Analysis Program (ATTAP) website, jointly initiated by the Maryland State Highway Administration and the University of Maryland: [attap.umd.edu/uaid.php](http://attap.umd.edu/uaid.php)

### 1300.05 Design Vehicle Selection

When selecting a design vehicle for an intersection, address the needs of all users, including bicyclists and pedestrians, and the costs associated with the intersection control type. The primary use of the design vehicle is to determine radii for each of the intersections. It is possible for each turning movement to have a different design vehicle. [Exhibit 1300-1](#) shows commonly used design vehicle types in Washington State. Additional design vehicle types can be found in the AASHTO Green Book.



Evaluate the existing and anticipated future traffic to select a practical design vehicle that is the largest vehicle that will frequently use the intersection. [Exhibit 1300-2](#) shows the minimum design vehicles for expected uses. Justify the decision to use a smaller vehicle, which may be practical; include a traffic analysis showing that the proposed vehicle(s) is appropriate. Consider oversized vehicles for intersections that are commonly used to route oversized loads.

Vehicle Type	Design Symbol
Passenger car, including light delivery trucks	P
City transit bus	CITY-BUS
Articulated bus	A-BUS
Single-unit truck	SU-30
Semitrailer truck, overall wheelbase of 40 ft	WB-40
Semitrailer truck, overall wheelbase of 67 ft	WB-67

### Design Vehicle Types

*Exhibit 1300-1*

Intersection Types and Use	Minimum Design Vehicle
Junction of Major Truck Routes, Junction of State Routes, Ramp Terminals, Roundabouts	WB-67
Other Rural & Industrial	WB-40
Commercial & Residential	SU-30 [1][2]
<p><b>Notes:</b></p> <p>[1] To accommodate pedestrians, the P vehicle may be used as the design vehicle when justified in a traffic analysis.</p> <p>[2] When the intersection is on a transit or school bus route, use the CITY-BUS design vehicle as a minimum. (See <a href="#">Chapter 1430</a> for additional guidance on transit facilities.)</p>	

### Minimum Intersection Design Vehicle

*Exhibit 1300-2*

## 1300.06 Procedures

For new intersections, determine and document traffic control according to the applicable procedures in this chapter.

For intersection improvement projects involving pavement construction and/or reconstruction, signal replacement/rehabilitation, evaluate intersection control in accordance with this chapter unless there is documentation that this analysis has already been completed and is referenced in the Project Summary.

Control for existing intersections that are unaffected by the project or are receiving minor revisions such as signal phasing changes (as shown through the analysis) may remain in place without further evaluation. Document the impacts and recommended revisions to all intersections affected by the project.

### 1300.06(1) Intersection Control Analysis (ICA)

Use the following steps when screening intersection control alternatives for selection, or to support the need for modifications to existing intersection control:

- **Determine the right of way requirements and feasibility.** Discuss the right of way requirements and the feasibility of acquiring that right of way in the analysis. Include sketches or plan sheets with sufficient detail to identify topography (including utilities), environmental constraints, drainage, buildings, and other fixed objects. An economic evaluation will be useful if additional right of way is needed. Include the right of way costs in the benefit/cost analysis.
- **Check signal warrants.** Evaluate existing peak period counts to determine the need for additional count data. If these counts do not meet a warrant, it is unlikely that a warrant will be met, so obtaining 12- or 24-hour count information is likely unnecessary. In some cases, the project may alter traffic patterns at an existing signal enough that it may no longer meet a warrant. For a list of the traffic signal warrants and information on how to use them, see the [MUTCD](#).

For new intersections, project hourly volumes, and movements using established methodology, see [Chapter 320](#).

If warrants are met, evaluate multi-way stop, roundabout, and signal. If warrants are not met, evaluate yield, two-way stop, multi-way stop, and roundabout. Unconventional configurations can also be considered if standard forms of control do not satisfy the objectives.

- **Determine environmental impacts.** Evaluate the impacts and permit requirements of each intersection control option (see the [Environmental Procedures Manual](#)). Any environmental risks that may substantially increase the cost of the project should be identified early in the process. Risk impacts to each alternative should be quantified for comparison.
- **Analyze alternatives and document the selection.** In addition to documenting the screening process for selecting the alternatives to be analyzed, the Intersection Control Analysis should include the following information: Existing Conditions, Delay Analysis, Operational Considerations, Benefit/Cost Analysis, Bicycle and Pedestrian Facilities, Context-Specific/Sustainable Design, and any Additional Information that is relevant. ***The single-lane roundabout is the preferred alternative. If selected, no comparison with other alternatives is required.***

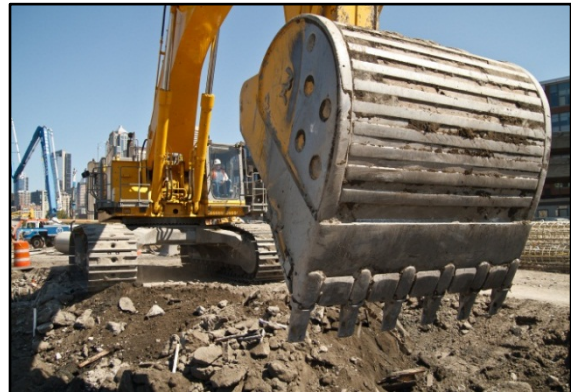

#### 1300.06(1)(a) Existing Conditions

The physical characteristics of the site include posted speed, traffic counts (Tuesday through Thursday average and peak hour manual counts), sight distance, channelization, pedestrian and bicycle facilities, and design vehicle.

Analyze the collision history and use current diagnostic tools to determine the expected and predicted collision rates for the existing conditions. Identify any problematic movements.



### 1300.06(1)(b) Delay Analysis

Since two or more traffic streams cross, converge, or diverge at intersections, the capacity of an intersection is normally less than the roadway between intersections. (See [Chapter 320](#) for additional details of Traffic Analysis.)

Provide a plan of the intersection used for modeling. Include recommendations for channelization, turn lanes, and acceleration and deceleration lanes for the preferred option for each intersection. Turn prohibitions may be used to increase intersection capacity. Analyze all relevant peak periods (with a.m. and p.m. as a minimum) for all intersection control alternatives. Holidays and special or seasonal events of short duration are generally not considered in the level of service (LOS) determination, although there are situations where a minor leg peak hour determines the hour used in analysis. Evaluating the 24-hour volumes may be necessary to maximize capacity and support the choice of intersection control that performs with the least overall delay.

Include the following in the delay analysis:

- Use 20 years after the year construction is scheduled to begin as the design year of the analysis for WSDOT projects. The design year will vary for developers and local agency projects (see [Chapter 320](#)).
- Identify and justify any growth rate used for design year analyses.
- Provide turning-movement volumes for all scenarios.
- Discuss the steps taken to arrive at the peak hour volume determination and how it relates to design hourly volume (DHV).

When the intersection improvements will be staged (for example, a roundabout opened as a single lane roundabout with plans to expand to a multilane roundabout when needed for capacity), include the anticipated date when the second stage will be required.

There are several deterministic and microsimulation programs for analyzing delay and intersection performance. Traffic volumes and the proximity of the project to other access points will dictate the modeling effort required. Contact the region Traffic Office to determine the appropriate approved program. With each iteration, ensure the proposed design for the intersection is in agreement with what is being modeled. For example, in modeling signals, a free right turn affects timings and also removes those vehicles from consideration in warrant analysis.

#### 1. Two-Way Stop Control

When the through roadway daily traffic is 3,500 or less, delay analysis is not required except in cases where the higher-volume roadway is controlled or where channelization is proposed. This is because adequate LOS for channelization projects does not always correlate to operational safety.

#### 2. Multi-Way Stop Control

Analyze according to the guidance provided in the [MUTCD](#).

#### 3. Roundabouts

Provide a capacity analysis to estimate the entry capacity of each roundabout entry leg. Innovative capacity analysis is occasionally needed on projects where metering a heavy leg for short periods of the day allows the most efficient operation 24 hours a day. Contact the region Traffic Office for the specific calibration information to use.

#### 4. Signals

When modeling signals, consider the phasing design criteria contained in [Chapter 1330](#). This may be guided by available opposing left-turn clearances at an intersection. Also, evaluate pedestrian movements and accommodate them in the proposed cycle lengths. Check the modeled signal phasing and timing for its ability to be programmed into the signal controller.

Progression of main line traffic is one reason given for using traffic signals; however, there are several reasons why progression may not realistically be obtained or sustained. Signal spacing, left-turn movements, speed, volume (particularly side street volume), and pedestrian movements can all affect the ability to achieve progression.

Consult the region Traffic Office for information on current signal operations practices. (See [Chapter 1310](#) for additional guidance on turn lane considerations.)

#### 5. Unconventional Intersections

Operational considerations for modeling depend on the intersection design in question. They may include the LOS for turning movements, weaving requirements, the need for vehicle storage, acceleration lanes, and the LOS at the merge points. The analyst and reviewer should agree on what measures of effectiveness will be used.

### 1300.06(1)(c) Operational Considerations

The transportation network has a mix of intersection controls. Delay analysis focuses on determining the peak-hour letter-graded LOS of an individual intersection. Operational analysis is a more encompassing review of the ability of the intersection to provide sufficient capacity in the network, and includes consideration of the environment that users will encounter at all hours of the day.

Intersection control has an influence on approaches and other intersections, even at acceptable LOS. Increased delay affects route choice. A driver's willingness to accept delay depends on the current circumstances and the driver's knowledge of the transportation network. The arrival of in-vehicle guidance systems will only increase the tendency of drivers to seek out routes with shorter travel times. Thus, it is important to consider the effects of intersection control on the surrounding network. Document the existing and proposed design. Points that may need to be addressed include the following:

- Using access management alternatives such as rerouting traffic to an existing intersection with available capacity. Check with WSDOT region Planning Office for future land use plans or comprehensive plans to provide for future growth accommodation. Discuss options and strategies that have been developed through a collaborative planning process with the local agency or, where appropriate, the regional or metropolitan transportation planning organization.
- The volume to capacity (V/C) ratio, the delay, and the queue length of the legs. Roundabout V/C ratios above 0.92 may require additional sensitivity analysis to determine the impacts of small changes in volume. Discuss the results of the capacity analysis and the lanes necessary for each leg of the intersection.
- Compare the geometry/number of lanes required by different alternatives to achieve similar results.
- The effect on other travel modes: rail, bus, pedestrian, and bicycle.

- The effects of existing conditions. Discuss progression through nearby intersections (corridor and network analysis) and known risky or illegal driving maneuvers. Work with the region Traffic Office to verify the network area of influence.
- How the proposed control will meet the objectives for intersection control (see 1300.04) at all hours compared to other alternatives. This is particularly applicable when only the peak hour warrant is met for a signal, since it is only used in rare cases.
- The possibility that traffic from other intersections with lower levels of service will divert to the new/revised intersection.
- Compare the predicted collision frequency of the alternatives. Discuss how each proposed solution might affect safety performance and collision types.
- Identify the design vehicle (see 1300.05). Include truck types and sizes (including oversized vehicles) that travel through the area both currently and in the future. Include verification of turning movements based on turn simulation software (such as AutoTURN<sup>®</sup>).
- Queue lengths must be examined in areas where there are intersections or approaches in close proximity. When other intersections are affected, if needed, use a calibrated simulation to fully evaluate the operational effects of the proposed traffic control on the system.
- Sight distances (stopping, intersection, decision) for the proposed designs must be evaluated prior to selection of an alternative.

#### 1300.06(1)(d) Benefit/Cost Analysis

Benefit/cost analysis compares the value of benefits against costs. There is considerable debate on what can and should be included in this analysis, particularly in the area of environmental and societal benefits and costs. Generally, and in keeping with the objectives of intersection control, the only societal costs/benefits WSDOT evaluates are those due to collisions and delay. Include the following in the analysis:

- Project costs related to design, right of way, and construction.
- Annual maintenance cost differences between the options. For signals, this also includes the cost to review the signal timings in accordance with current signal operations guidelines. This value can be obtained from the region Traffic Office.
- 24-hour travel time savings. Workbook and annual information can be found at:  
☞ [www.wsdot.wa.gov/mapsdata/travel/mobility.htm](http://www.wsdot.wa.gov/mapsdata/travel/mobility.htm)
- Use a predicted method to compare societal benefits or costs calculated from the change in collision severity and/or frequency.
- Salvage value of right of way, grading and drainage, and structures.

#### 1300.06(1)(e) Bicycle and Pedestrian Facilities

Discuss the facilities to be provided for and used by bicycles and pedestrians. Include required ADA accommodations.

For consideration of bicycle and pedestrian needs at intersections, see Chapters 1510, 1515, and 1520. Additional emerging practices information can be found at the Pedestrian and Bicycle Information Center (☞ [www.pedbikeinfo.org/](http://www.pedbikeinfo.org/)) and the NACTO Urban Bikeway Design Guide (☞ <http://nacto.org/cities-for-cycling/design-guide/>).

### 1300.06(1)(f) Context Sensitive/Sustainable Design

Context sensitive design is a model for transportation project development. A proposed transportation project must be planned not only for its physical aspects as a facility serving specific transportation objectives, but also for its effects on the aesthetic, social, economic, and environmental values, needs, constraints, and opportunities in a larger community setting. Projects designed using this model:

- Optimize safety of the facility for both the user and the community.
- Promote multimodal solutions.
- Are in harmony with the community, and preserve the environmental, scenic, aesthetic, historic, and natural resource values of the area.
- Are designed and built with minimal disruption to the community.
- Involve efficient and effective use of the resources (time, budget, community) of all involved parties.



### 1300.06(1)(g) Additional Information

Discuss the following in the intersection analysis as needed to further support the selection (is it an item that will have a significant effect on the decision?):

- Information from the Route Development Plan or other approved corridor study.
- Environmental permitting restrictions, such as the ones in place in scenic areas and other locations with similar restrictions.
- Current and future land use and whether or not the intersection control will reasonably accommodate future land use traffic changes.
- Current/proposed speed limits (changes in speed limits can affect signal warrants).
- Public meeting comments.
- Outside agency coordination and comments.
- Medians, lane widths, and parking.
- Effect on future local agency projects.
- Other elements considered in the selection of the intersection control.

### 1300.06(2) Public Involvement

Public acceptance of stop and signal control is currently such that outreach efforts are seldom required beyond keeping the public informed as to the status of the project. In contrast, roundabouts, particularly the first in an area, require a holistic approach. Technical, public, and political aspects must be considered. Education and outreach efforts, if necessary, are collaborative and are most useful during the analysis and early design stages. (See [Chapter 210](#) for further information.)



### **1300.06(3) Approval**

Refer to [Chapter 300](#) for additional information on approval authorities. Approval of intersection control type (to be completed no later than the scoping phase) requires the following:

- HQ Concurrence
- Region Approval

### **1300.06(4) Corridor Analyses**

Intersections included in approved Route Development Plans or approved Corridor Analyses are eligible for Intersection Control Approval by the Region Traffic Engineer provided they have been analyzed in accordance with this chapter. Approval is valid for three years.

### **1300.06(5) Local Agency or Developer-Initiated Intersections**

[Chapter 320](#) provides guidance for preparation of a Traffic Impact Analysis (TIA). Early in the design process, coordinate with the region to identify specific intersections for further analysis. The project initiator provides an Intersection Control Analysis (ICA) for approaches and intersections with state routes per [1300.06\(1\)](#), or references this information in the TIA. The project initiator documents the design considerations and submits the ICA and all documentation to the region for approval (per [1300.06\(1\)](#)). After the ICA is approved, finalize the intersection design and obtain approval per [Chapters 300](#) (for documentation), [1310](#) (for intersections), [1320](#) (for roundabouts), and [1330](#) (for traffic signals).

Intersections in local agency projects submitted for grants administered by the department are subject to the requirements of this chapter. Intersections on state routes must receive intersection control approval as a condition of application.

## **1300.07 Documentation**

Refer to [Chapter 300](#) for design documentation requirements.



- 1310.01 General
- 1310.02 References
- 1310.03 Design Considerations
- 1310.04 Design Elements
- 1310.05 U-Turns
- 1310.06 Intersection Sight Distance
- 1310.07 Signing and Delineation
- 1310.08 Procedures
- 1310.09 Documentation

## 1310.01 General

Intersections are a critical part of Washington State Department of Transportation (WSDOT) highway design because of increased conflict potential. Traffic and driver characteristics, bicycle and pedestrian needs, physical features, and economics are considered during the scoping and design stages to develop channelization and traffic control to provide multimodal traffic flow through intersections.

This chapter provides guidance for designing intersections, including ramp terminals. Refer to the following chapters for additional information:

Chapter	Subject
<a href="#">1300</a>	<u>Intersection control type</u>
<a href="#">1320</a>	Roundabouts
<a href="#">1330</a>	Traffic signals
<a href="#">1340</a>	<u>Driveways</u>
<a href="#">1360</a>	Interchanges
<a href="#">1510</a>	<u>Pedestrian facilities</u>

For assistance with intersection design, contact the Headquarters (HQ) Design Office.

## 1310.02 References

### 1310.02(1) Federal/State Laws and Codes

Americans with Disabilities Act of 1990 (ADA) ([28 CFR Part 36](#), Appendix A)

[Revised Code of Washington \(RCW\) 35.68.075](#), Curb ramps for persons with disabilities – Required – Standards and requirements

[Washington Administrative Code \(WAC\) 468-18-040](#), Design standards for rearranged county roads, frontage roads, access roads, intersections, ramps and crossings

[WAC 468-52](#), Highway access management – Access control classification system and standards

### 1310.02(2) Design Guidance

*Local Agency Guidelines* (LAG), M 36-63, WSDOT

*Manual on Uniform Traffic Control Devices for Streets and Highways*, USDOT, FHWA; as adopted and modified by [Chapter 468-95 WAC](#) “Manual on uniform traffic control devices for streets and highways” (MUTCD)

*Standard Plans for Road, Bridge, and Municipal Construction (Standard Plans)*, M 21-01, WSDOT

### 1310.02(3) Supporting Information

*A Policy on Geometric Design of Highways and Streets (Green Book)*, AASHTO

*Aspects of Traffic Control Devices*, Highway Research Record No. 211, pp 1-18, “Volume Warrants for Left-Turn Storage Lanes at Unsignalized Grade Intersections,” Harmelink, M.D.

*Guidelines and Recommendations to Accommodate Older Drivers and Pedestrians*, FHWA-RD-01-051, USDOT, FHWA, May 2001

*Highway Capacity Manual (HCM)*, Special Report 209, Transportation Research Board, National Research Council

*Intersection Channelization Design Guide*, NCHRP 279

## 1310.03 Design Considerations

Consider all potential users of the facility in the design of an intersection. This involves addressing the needs of a diverse mix of user groups, including passenger cars, heavy vehicles of varying classifications, bicycles, and pedestrians. Often, meeting the needs of one user group results in a compromise in service to others. Intersection design balances these competing needs, resulting in appropriate levels of operation for all users.

In addition to reducing the number of conflicts, minimize the conflict area as much as possible while still providing for the design vehicle (see [Chapter 1300](#)). This is done to control the speed of turning vehicles and reduce the area of exposure for vehicles, bicycles, and pedestrians. For additional information on pedestrian needs, see [Chapter 1510](#). For intersections with shared-use paths, see [Chapter 1515](#). For bicycle considerations at intersections, see [Chapter 1520](#).

### 1310.03(1) Nongeometric Considerations

Geometric design considerations, such as sight distance and intersection angle, are important. Equally important are perception, contrast, and a driver’s age. Perception is a factor in the majority of collisions. Regardless of the type of intersection, the function depends on the driver’s ability to perceive what is happening with respect to the surroundings and other vehicles. When choosing an acceptable gap, the driver first identifies the approaching vehicle and then determines its speed. The driver uses visual clues provided by the immediate surroundings in making these decisions. Thus, given equal sight distance, it may be easier for the driver to judge a vehicle’s oncoming speed when there are more objects to pass by in the driver’s line of sight. Contrast allows drivers to discern one object from another.

### 1310.03(2) Intersection Angle and Roadway Alignment

An important intersection design characteristic is the intersection angle. The desirable intersection angle is 90°, with 60° to 120° allowed.



Do not put angle points on the roadway alignments within intersection areas or on the through roadway alignment within 100 feet of the edge of traveled way of a crossroad. However, angle points within the intersection are allowed at intersections with a minor through movement, such as at a ramp terminal (see [Exhibit 1310-2](#)).

When feasible, locate intersections such that curves do not begin or end within the intersection area. It is desirable to locate the PC and PT 250 feet or more from the intersection so that a driver can settle into the curve before the gap in the striping for the intersection area. Do not locate short curves where both the PC and PT are within the intersection area.

**1310.03(3) Lane Alignment**

It is desirable that entering through traffic is aligned with the exit lanes. However, the entering and exit lanes may be offset up to 6 feet when the following conditions are met:

- Illumination is provided.
- The intersection is not within a horizontal curve, nor is it within a crest vertical curve.
- The taper rates provided in [Exhibit 1310-1](#) are used.
- There is a posted speed of 55 mph or less.

Consider dotted extension lines that continue through the intersection.

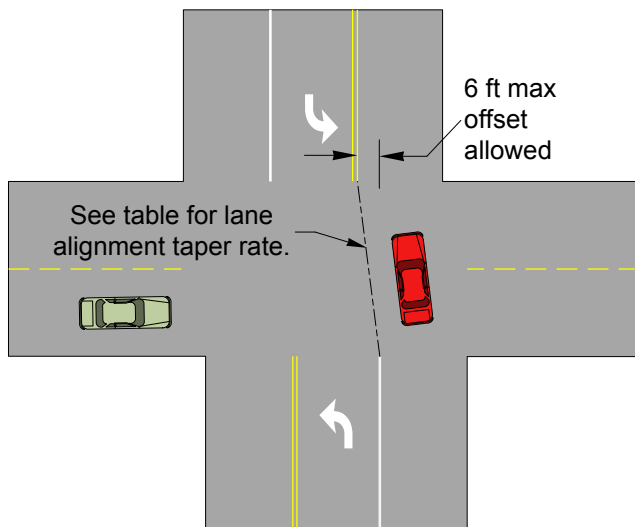

Posted Speed	Taper Rate
55 mph	55:1
50 mph	50:1
45 mph	45:1
40 mph	27:1
35 mph	21:1
30 mph	15:1
25 mph	11:1

**Lane Alignment Taper Rate**  
*Exhibit 1310-1*

### 1310.03(4) **Intersection Spacing**

Provide intersection spacing for efficient operation of the highway. The minimum design intersection spacing for highways with limited access control is covered in [Chapter 530](#). For other highways, the minimum design intersection spacing is dependent on the managed access highway class. (See [Chapter 540](#) for minimum intersection spacing on managed access highways.)

As a minimum, provide enough space between intersections for left-turn lanes and storage length. Space signalized intersections and intersections expected to be signalized to maintain efficient signal operation. Space intersections so that queues will not block an adjacent intersection.

Evaluate existing intersections that are spaced less than shown in [Chapters 530](#) and [540](#). Also, evaluate closing or restricting movements at intersections with operational issues. Document the spacing of existing intersections that will remain in place and the effects of the spacing on operation, capacity, and circulation.

### 1310.03(5) **Accommodating vs. Designing for Vehicles**

Accommodating for a vehicle allows encroachment of other lanes, shoulders, or other elements to complete the required maneuver. Designing for a vehicle does not require encroachment on those elements.

There are competing design objectives when considering the crossing needs of pedestrians and the turning needs of larger vehicles. To design for large design vehicles, larger turn radii are used. This results in increased pavement areas, longer pedestrian crossing distances, and longer traffic signal arms. (See [Chapter 1300](#) for design vehicle selection criteria.)

When appropriate, to reduce the intersection area, consider accommodating for large vehicles instead of designing for them. This reduces the potential for vehicle/pedestrian conflicts, decreases pedestrian crossing distance, and controls the speeds of turning vehicles. Use turn simulation software (such as AutoTURN<sup>®</sup>) to verify the design.

### 1310.03(6) **Sight Distance**

For stopping and decision sight distance criteria, see [Chapter 1260](#). Intersection sight distance criteria are discussed in section [1310.06](#).

### 1310.03(7) **Crossroads**

When the crossroad is a city street or county road, design the crossroad beyond the intersection area according to the applicable design criteria given in [Chapter 1140](#).

When the crossroad is a state facility, design the crossroad according to the applicable design level and functional class (see [Chapters 1120](#), [1130](#), and [1140](#)). Continue the cross slope of the through roadway shoulder as the grade for the crossroad. Use a vertical curve that is at least 60 feet long to connect to the grade of the crossroad.

Evaluate the profile of the crossroad in the intersection area. The crown slope of the main line might need to be adjusted in the intersection area to improve the profile for the cross traffic.

Design the grade at the crosswalk to meet the requirements for accessibility. (See [Chapter 1510](#) for additional crosswalk information.)

In areas that experience accumulations of snow and ice for all legs that require traffic to stop, design a maximum grade of  $\pm 4\%$  for a length equal to the anticipated queue length for stopped vehicles.

**1310.03(8) Rural Expressway At-Grade Intersections**

Evaluate grade separations at all intersections on rural expressways.

Design high-speed at-grade intersections on rural expressways as indirect left turns, split intersections, or roundabouts.

The State Traffic Engineer's approval is required for any new intersection or signal on a rural expressway.

**1310.03(9) Interchange Ramp Terminals**

When stop control or traffic signal control is selected, the design to be used or modified is shown in [Exhibit 1310-2](#). Higher-volume intersections with multiple ramp lanes are designed individually. Provide ramp terminal designs consistent with the speed of the crossroad.

Where stop control or signal control is implemented, the intersection configuration criteria for ramp terminals are normally the same as for other intersections. One exception is that an angle point is allowed between an off-ramp and an on-ramp. This is because the through movement of traffic getting off the freeway, going through the intersection, and getting back on the freeway is minor.

Another exception is at ramp terminals where the through movement is eliminated (for example, at a single-point interchange). For ramp terminals that have two wye connections, one for right turns and the other for left turns, and no through movement, the intersection angle has little meaning and does not need to be considered.

Due to the probable development of large traffic generators adjacent to an interchange, width for a median on the local road is desirable whenever such development is expected. This allows for future left-turn channelization. Use median channelization when justified by capacity determination and analysis or by the need to provide a smooth traffic flow.

Adjust the alignment of the intersection legs to fit the traffic movements and to discourage wrong-way movements. Use the allowed intersecting angles of 60° to 120° in designing the best alignment for efficiency and intersection operations.

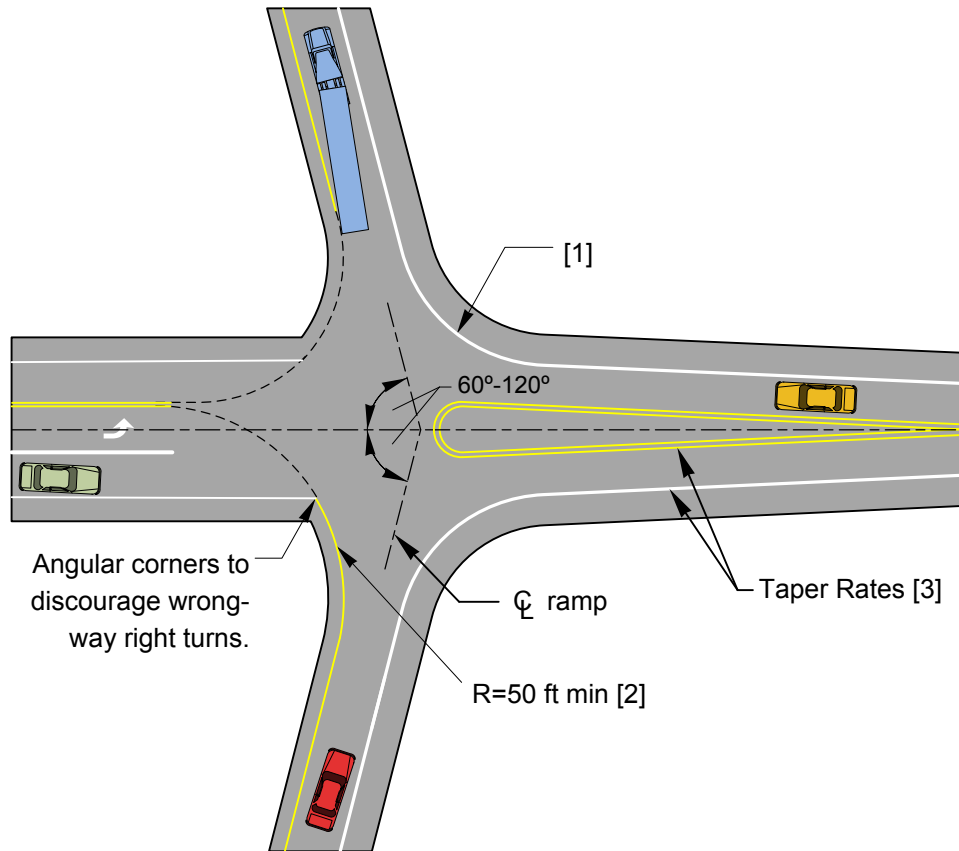
**Notes:**

- [1] For right-turn corner design, see [Exhibit 1310-6](#).  
 [2] Use turn simulation software to verify that the design vehicle can make the turn.  
 [3] For taper rates, see [Exhibit 1310-10a](#), Table 1.

**Ramp Terminal Intersection Details**  
*Exhibit 1310-2*

### 1310.03(10) Wrong-Way Movement Countermeasures

Wrong-way collisions, though infrequent, have the potential to be more serious than other types of collisions, especially on high-speed facilities. Collision data show that impaired and older drivers are overrepresented and that a high percentage of these occurrences are at night. Washington State data show approximately equal numbers of collisions on the Interstate and multilane urban principal arterial highways. Discourage wrong-way maneuvers at all stages of design.

#### 1310.03(10)(a) Wrong-Way Driving Countermeasure Categories

There are three categories of countermeasures to discourage wrong-way driving:

- Signing and delineation
- Intelligent transportation systems
- Geometric design

## 1. Signing and Delineation

Signing and delineation countermeasures include:

- DO NOT ENTER and WRONG WAY signs.
- ONE WAY signs.
- Turn restriction signs.
- Red-backed raised pavement markers (RPMs).
- Directional pavement arrows.
- Yellow edge line on left and white edge line on right side of exit ramps.
- Pavement marking extension lines to direct drivers to the correct ramp.

Signing can be a more effective countermeasure when the signs are lowered. At night, lowered signs are better illuminated by low-beam headlights. Other improvements may include a second set of signs, supplemental sign placards, oversized signs, flashing beacons, internal illumination, overhead-mounted signs, red reflective tape on the back of signs, extra overhead lighting, and red-backed guideposts on each side of the ramp up to the WRONG WAY sign.

## 2. Intelligent Transportation Systems (ITS)

Wrong-way ITS countermeasures are wrong-way detection and warning systems. Contact the region Traffic Office for assistance when considering an ITS wrong-way warning system.

## 3. Geometric Design

Geometric countermeasures include separating wrong-way movements from other movements, discouraging wrong-way movements, encouraging right-way movements, and improving the visibility of the right-way movement.

### a. Separate On- and Off-Ramp Terminals

Consider the separation of on- and off-ramp terminals, particularly at interchanges where the ramp terminals are closely spaced (for example, partial cloverleaf ramps combined with other ramps). Wider medians between off- and on-ramp terminals provide room for signing and allow the median end to be shaped to help direct vehicles onto the correct roadway. The minimum width of the raised median is 7 feet, face of curb to face of curb, to accommodate a 36 inch sign.

Extend the raised median on a two-way ramp from the ramp terminal intersection to the split of the on- and off-ramps. The median outside of the intersection area may be reduced to the width of a dual-faced mountable curb. (See [Exhibit 1310-3](#) for an example of the minimum median at the terminal of a two-way ramp.)

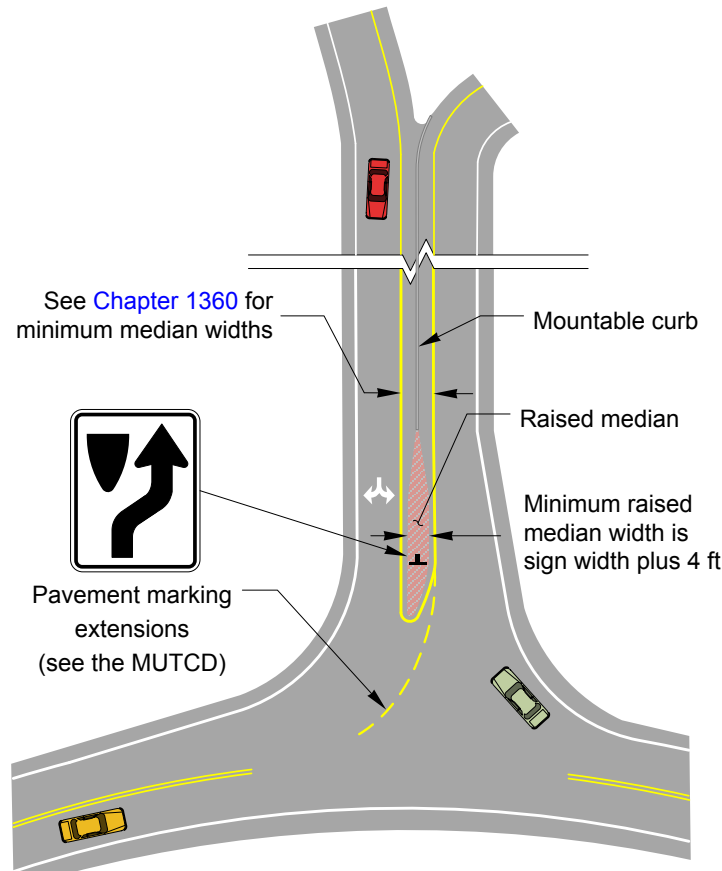

### Median at Two-Way Ramp Terminal

*Exhibit 1310-3*

#### b. Reduced Off-Ramp Terminal Throat Width

Reducing the width of the off-ramp throat has been a successful method of discouraging wrong-way movements. A smaller opening makes the wrong-way entry less inviting, particularly for closely spaced ramps. When off-ramp terminals have right-turn lanes, a raised island will reduce the potential for a wrong-way movement.

#### c. Increased On-Ramp Terminal Throat Width

Increasing the width of the on-ramp throat can encourage right-way movements. A larger opening for the on-ramp makes it easier to turn into. To increase the throat width of on-ramps, use flat radii for left- and right-turning traffic and remove islands.

#### d. Intersection Balance

When drivers make a left turn, they are required to leave the intersection in the extreme left-hand lane lawfully available. As a result, left-turning drivers tend to head for a point between 50% and 60% of the way through the intersection.

At a two-way ramp terminal, the desirable throat width for the on-ramp roadway is not less than the off-ramp roadway width to accommodate this behavior (see [Exhibit 1310-4](#)). Much of this can be achieved by adjusting the stop bar position on the interchange cross street.

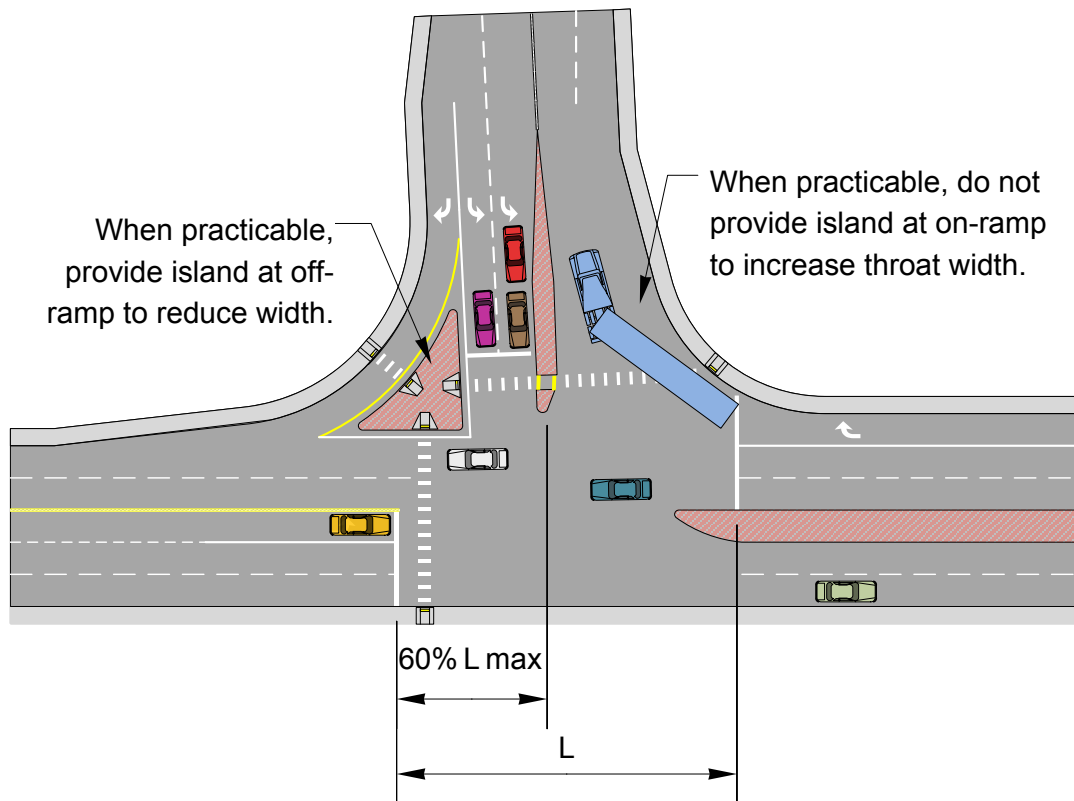

### Intersection Balance Example

*Exhibit 1310-4*

#### e. Visibility

When drivers can see and recognize the roadway they want to turn onto, they are less likely to make a mistake and turn onto the wrong roadway. For two-way ramps and divided multilane roadways with barrier in the median, end the barrier far enough from the intersection that a left-turning driver can see and recognize the roadway going the correct direction. Drivers need to see the delineation pavement markings, curbs, or other elements to locate the correct roadway.

#### f. Angular Corners on the Left of Off-Ramp Terminals

Angular corners on the left side of off-ramp terminals will discourage wrong-way right turns. Provide a corner design as angular as feasible that will provide for the left turn from the off-ramp. Circular curves can look inviting for a wrong-way right turn onto the off-ramp (see [Exhibit 1310-2](#)).

### 1310.03(10)(b) Countermeasure Applications

Following are applications of wrong-way countermeasures for some common locations. For assistance with signing and delineation, contact the region Traffic Office.

### 1. All Ramps

Countermeasures that can be used on almost any ramp or intersection with potential wrong-way concerns include:

- Enlarged warning signs.
- Directional pavement arrows at ramp terminals.
- Redundant signing and pavement arrows.
- Roundabout ramp terminal intersections, where room is available.
- Red-backed RPMs.

### 2. One-Way Diamond Off-Ramp

Diamond interchanges are common, and although drivers are familiar with them, they can still get confused and go the wrong way. In addition to signing and pavement markings for these interchanges, provide:

- Angular corners to discourage wrong-way right turns.

### 3. Diamond Interchange With Advance Storage

Diamond interchanges with advance storage have left-turn storage lanes that extend from the on-ramp past the off-ramp (see [Exhibit 1310-5](#)). This allows for a potential early left turn onto the off-ramp. Following are additional countermeasures for interchanges with advanced left-turn storage:

- Provide a raised median to discourage the wrong-way left turn.
- Provide signing and directional arrows to direct traffic to the correct left-turn point.

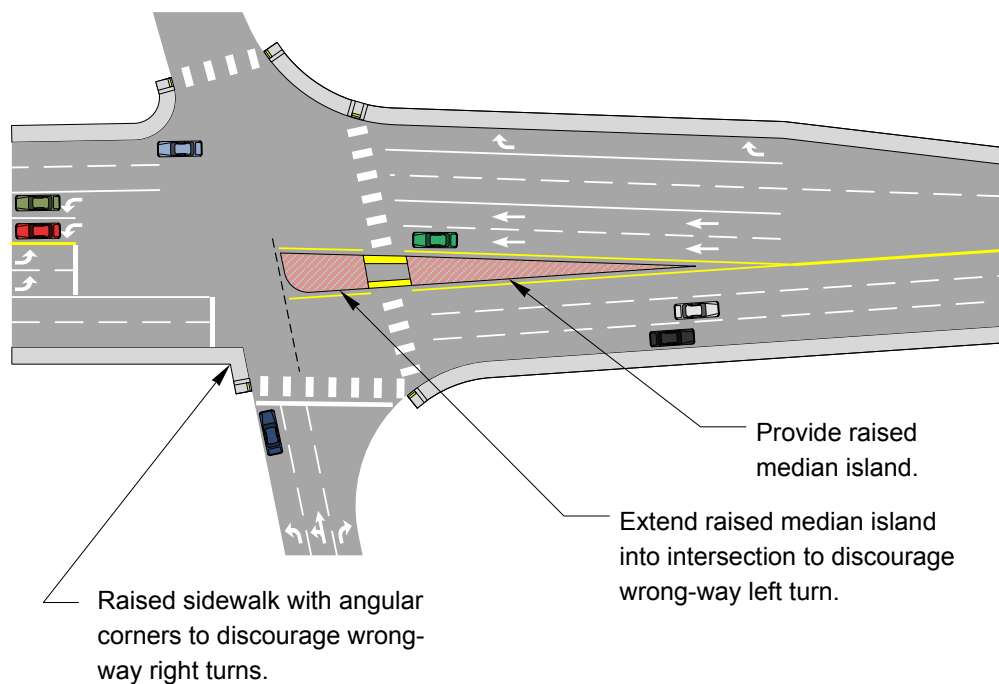

### Diamond Interchange With Advance Storage

*Exhibit 1310-5*



#### 4. Two-Way Ramps

Two-way ramps have the on- and off-ramp adjacent to each other. They are used at partial cloverleaf, trumpet, and button hook interchanges. Because the on and off roadways are close to each other, they are more vulnerable to wrong-way driving. Also, when the separation between on and off traffic is striping only, the ramps are susceptible to drivers entering the correct roadway and inadvertently crossing to the wrong ramp. In addition to signing and delineation, the following are countermeasures for two-way ramps:

- Separate the on- and off-ramp terminals.
- Reduce off-ramp terminal throat width.
- Increase on-ramp terminal throat width.
- Maintain intersection balance.
- Improve on-ramp visibility.
- Provide a raised median or dual-faced curb from the ramp terminal intersection to the gore nose.

#### 5. HOV Direct Access Ramps

HOV direct access ramps are two-way ramps in the median; therefore, the ability to provide separation between the on and off traffic is limited by the width of the median. An additional concern is that HOV direct access ramps are left-side ramps. Drivers normally enter the freeway using a right-side ramp and they may mistakenly travel the wrong way on a left-side ramp. Review existing and proposed signing for inadvertent misdirection. (See [Chapter 1420](#) for HOV direct access and countermeasures for wrong-way driving at HOV direct access ramps.)

#### 6. Multilane Divided Roadways

Wrong-way driving can also occur on multilane divided nonfreeway facilities. Wrong-way drivers may enter multilane divided facilities at driveways and at-grade intersections. Countermeasures for wrong-way driving on nonfreeway multilane divided highways include:

- Wrong-way signing and delineation at the intersections.
- Right-in/right-out road approaches.

### 1310.04 Design Elements

When designing an intersection, identify and address the needs of all intersection users.

If pedestrian facilities are present, the design objective becomes one of reducing the potential for vehicle/pedestrian conflicts. This is done by minimizing pedestrian crossing distances and controlling the speeds of turning vehicles. Pedestrian refuge islands can be beneficial. They minimize the pedestrian crossing distance, reduce the conflict area, and minimize the impacts on vehicular traffic. When designing islands, speeds can be reduced by designing the turning roadway with a taper or large radius curve at the beginning of the turn and a small radius curve at the end. This allows larger islands while forcing the turning traffic to slow down. Use turn simulation software (such as AutoTURN®) to verify the design.

Channelization, the separation or regulation of traffic movements into delineated paths of travel, can facilitate the orderly movement of pedestrians, bicycles, and vehicles. Channelization includes left-turn lanes, right-turn lanes, speed change lanes (both acceleration and deceleration lanes), and islands.

**1310.04(1) Right-Turn Corners**

Exhibit 1310-6 shows initial ranges for right-turn corner designs using a simple curve with a taper. These are considered approximate pavement areas to accommodate the design vehicles without encroachment on the adjacent lane at either leg of the curve.

Depending on the context of the roadway and right-turn corner (and whether the right-turn corner will be designed for or will accommodate a design vehicle), there may be several design considerations. Consider vehicle-pedestrian conflicts; vehicle encroachment on the shoulder or adjacent same-direction lane at the exit leg; capacity restrictions for right-turning vehicles or other degradation of intersection operations; and the effects on other traffic movements.

Other design considerations may include a combination of simple or compound curves, tapers at the beginning or end of the turn, and so on. Verify the design vehicle can make the turn using turn simulation software (such as AutoTURN®).

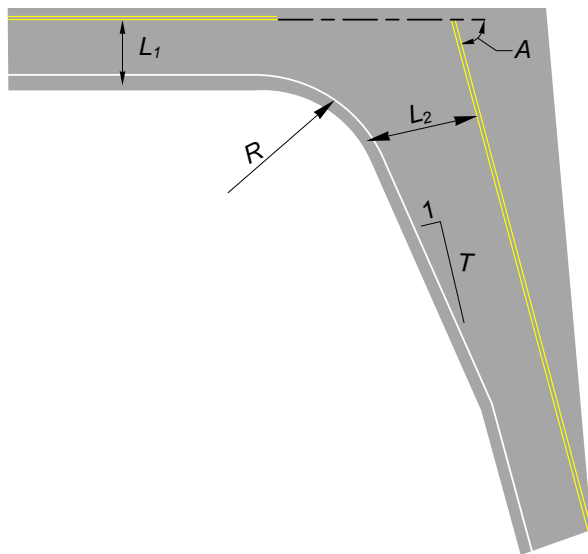

- $L_1$  = Available roadway width [2] that the vehicle is turning from
- $L_2$  = Available roadway width [2] for the vehicle leaving the intersection
- $R$  = Radius to the edge of traveled way
- $T$  = Taper rate (length per unit of width of widening)
- $A$  = Delta angle of the turning vehicle

Vehicle	A	R	$L_1$ [1]	$L_2$ [2]	T
P	All	30	11	11	25
SU-30 & CITY-BUS	All	50	11	11	25
WB-40	All	55	11	15	7.5
WB-67	All	50-85	11	22-24	7

**Notes:**

- [1] When available roadway width is less than 11 ft, widen at 25:1.
- [2] Available roadway width includes the shoulder, less a 2-ft clearance to a curb, and all the same-direction lanes of the exit leg at signalized intersections.

**General:**

All distances given in feet and angles in degrees.

**Initial Ranges for Right-Turn Corner (Simple Curve-Taper)**

Exhibit 1310-6

### 1310.04(2) Left-Turn Lanes and Turn Radii

Left-turn lanes provide storage, separate from the through lanes, for left-turning vehicles waiting for a signal to change or for a gap in opposing traffic. (See [1310.04\(4\)](#) for a discussion on speed change lanes.)

Design left-turn channelization to provide sufficient operational flexibility to function under peak loads and adverse conditions.

#### 1310.04(2)(a) One-Way Left-Turn Lanes

One-way left-turn lanes are separate storage lanes for vehicles turning left from one roadway onto another. One-way left-turn lanes may be an economical way to lessen delays and crash potential involving left-turning vehicles. In addition, they can allow deceleration clear of the through traffic lanes. Provide a minimum storage length of 100 feet for one-way left-turn lanes. When evaluating left-turn lanes, include impacts to all intersection movements and users.

At signalized intersections, use a traffic signal analysis to determine whether a left-turn lane is needed and the storage length. If the length determined is less than the 100-foot minimum, make it 100 feet (see [Chapter 1330](#)).

At unsignalized intersections, use the following as a guide to determine whether or not to provide one-way left-turn lanes:

- A traffic analysis indicates congestion reduction with a left-turn lane. On two-lane highways, use [Exhibit 1310-7a](#), based on total traffic volume (DHV) for both directions and percent left-turn traffic, to determine whether further investigation is needed. On four-lane highways, use [Exhibit 1310-7b](#) to determine whether a left-turn lane is recommended.
- A study indicates crash reduction with a left-turn lane.
- Restrictive geometrics require left-turning vehicles to slow greatly below the speed of the through traffic.
- There is less than decision sight distance for traffic approaching a vehicle stopped at the intersection to make a left turn.

A traffic analysis based on the *Highway Capacity Manual* (HCM) may also be used to determine whether left-turn lanes are needed to maintain the desired level of service.

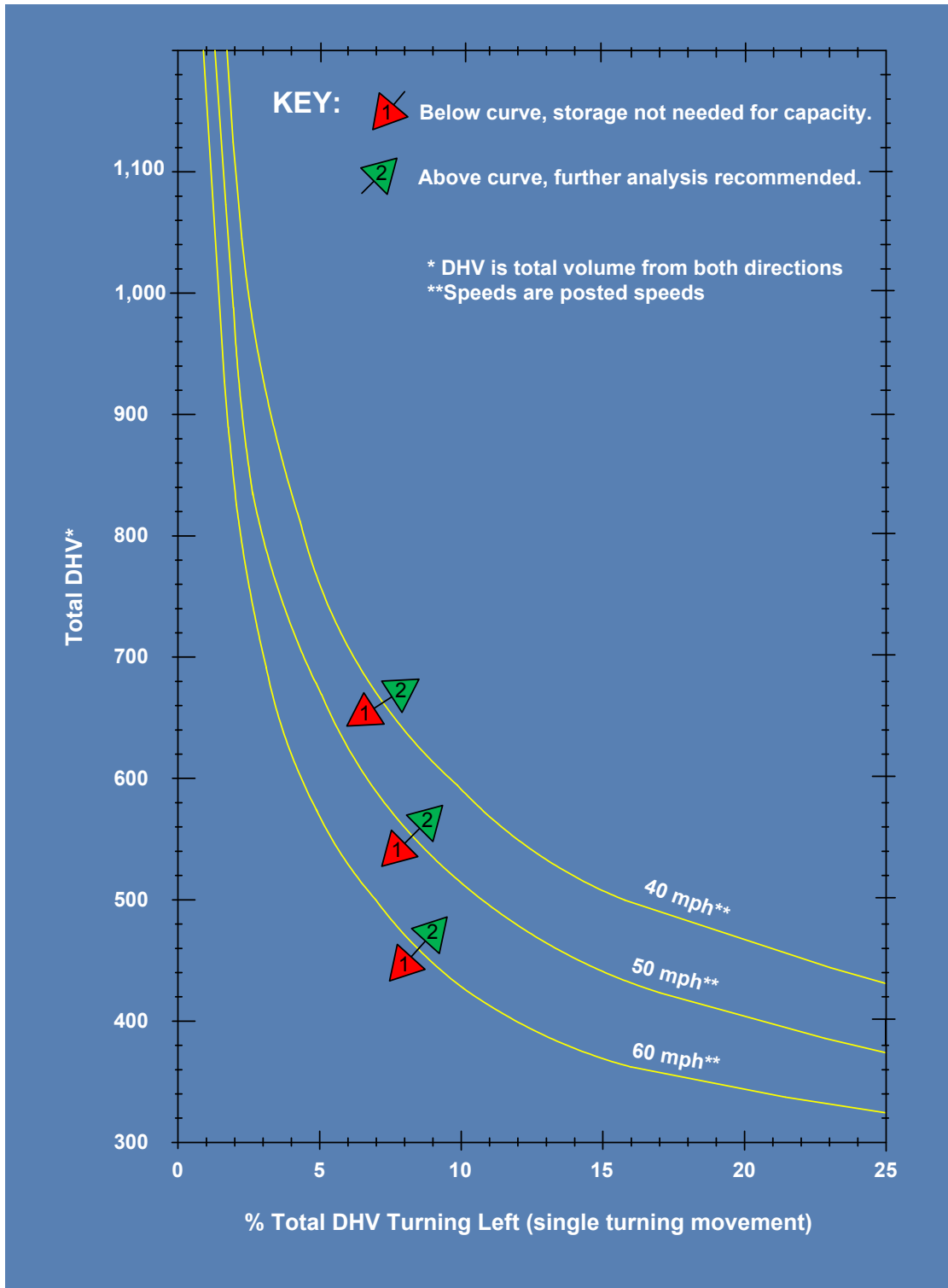

**Left-Turn Storage Guidelines: Two-Lane, Unsignalized**  
 Exhibit 1310-7a

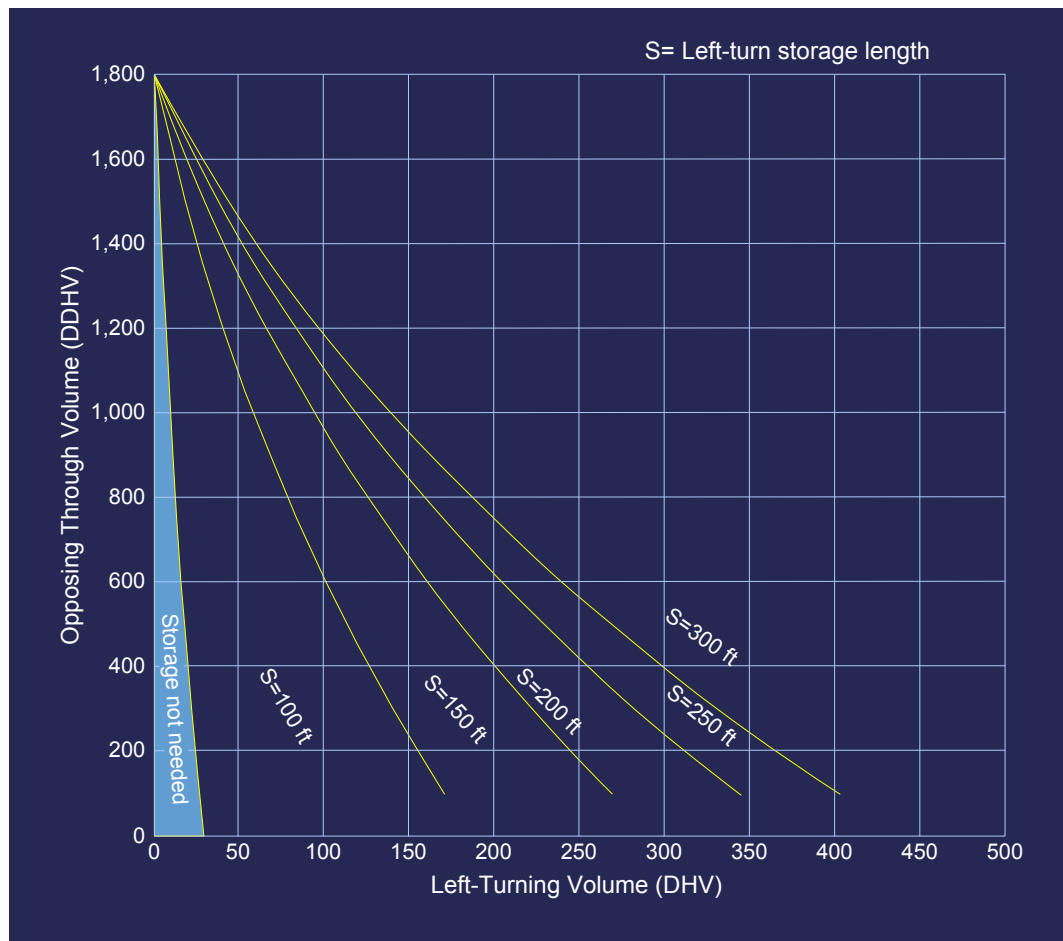

### Left-Turn Storage Guidelines: Four-Lane, Unsignalized

#### Exhibit 1310-7b

Determine the storage length on two-lane highways by using Exhibits 1310-8a through 8c. On four-lane highways, use Exhibit 1310-7b. These lengths do not consider trucks. Use Exhibit 1310-9 for storage length when trucks are present.

Use turn simulation software (such as AutoTURN<sup>®</sup>) to verify that left-turn movements for the design vehicle(s) do not have conflicts. Design opposing left-turn design vehicle paths with a minimum 4-foot (12-foot desirable) clearance between opposing turning paths.

Where one-way left-turn channelization with curbing is to be provided, evaluate surface water runoff and design additional drainage facilities if needed to control the runoff.

Provide illumination at left-turn lanes in accordance with the guidelines in Chapter 1040.

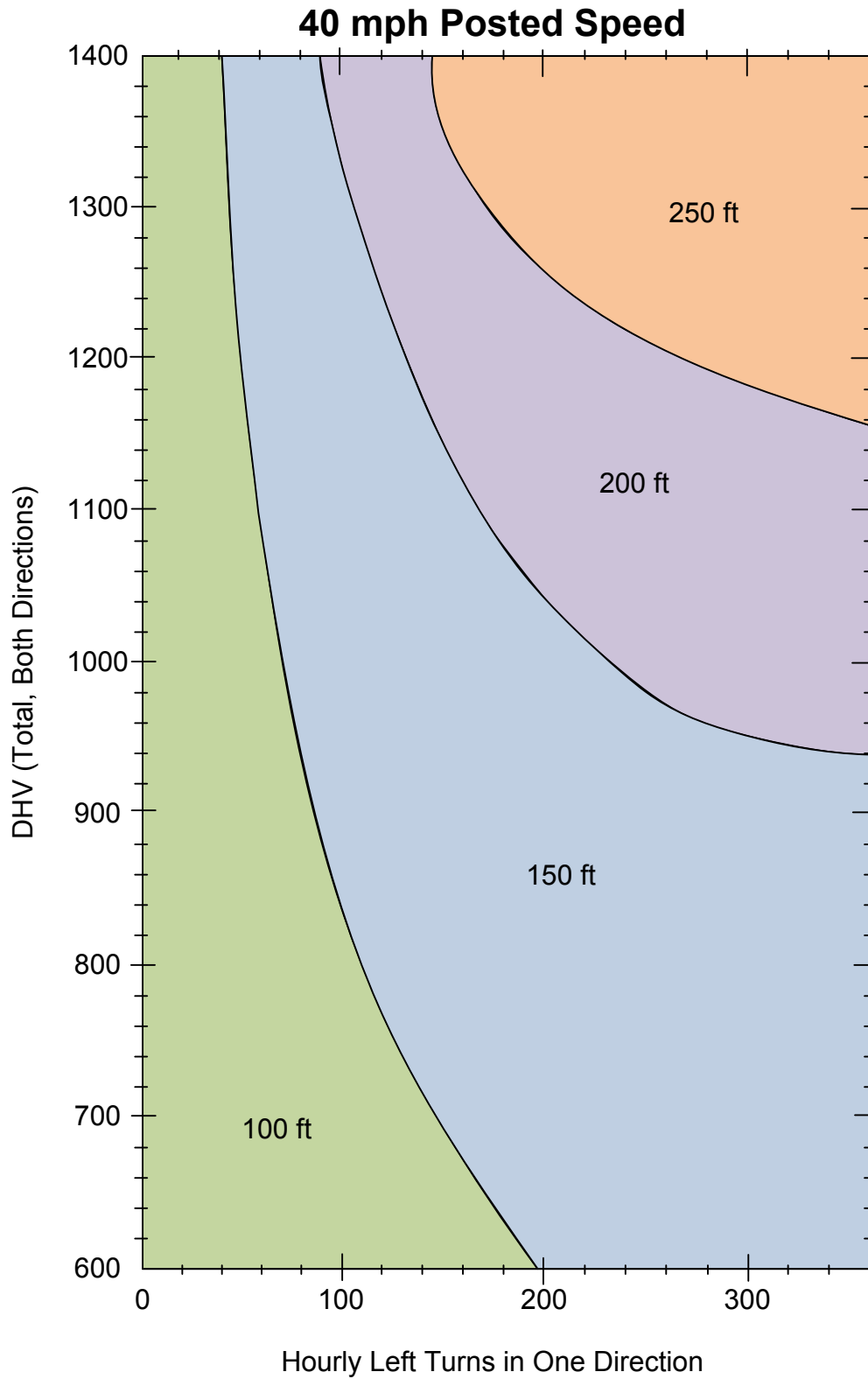

**Left-Turn Storage Length: Two-Lane, Unsignalized (40mph)**  
 Exhibit 1310-8a

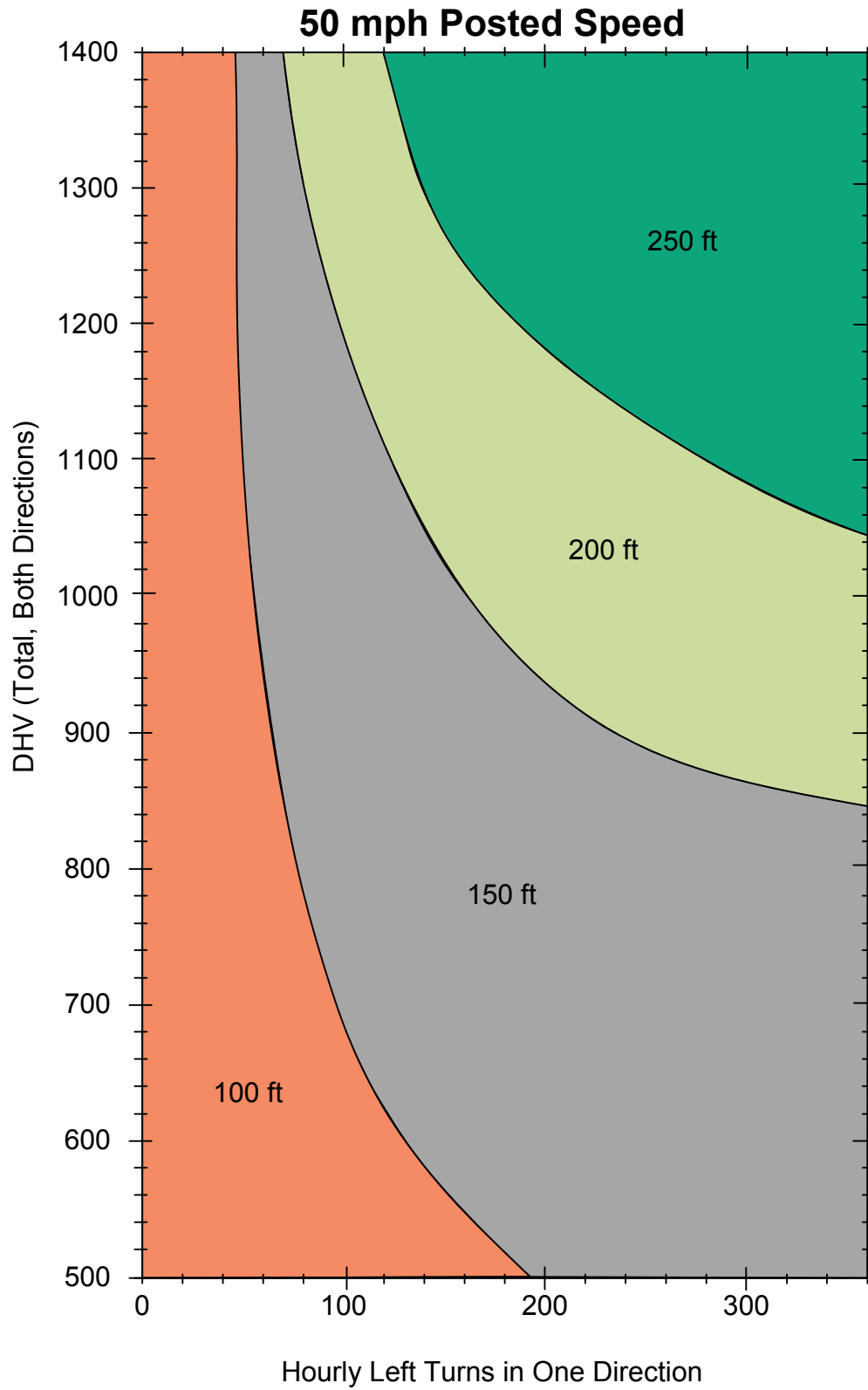

**Left-Turn Storage Length: Two-Lane, Unsignalized (50 mph)**  
*Exhibit 1310-8b*

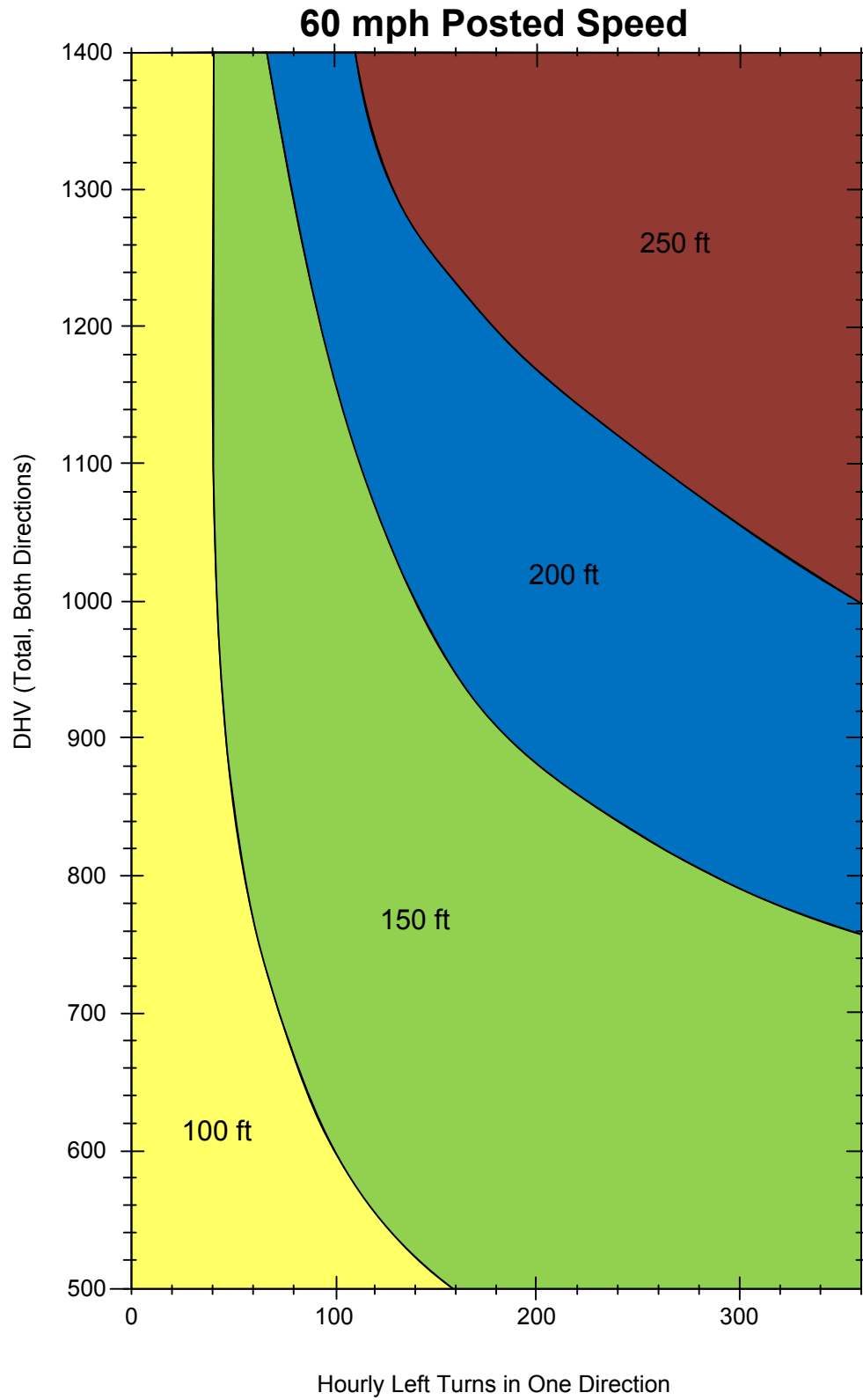

**Left-Turn Storage Length: Two-Lane, Unsignalized (60 mph)**  
*Exhibit 1310-8c*



Storage Length* (ft)	% Trucks in Left-Turn Movement				
	10	20	30	40	50
100	125	125	150	150	150
150	175	200	200	200	200
200	225	250	275	300	300
250	275	300	325	350	375
300	350	375	400	400	400

\*Length from Exhibits [1310-7b](#) and [1310-8a](#), [8b](#), or [8c](#).

### Left-Turn Storage With Trucks (ft) *Exhibit 1310-9*

At signalized intersections with high left-turn volumes, double (or triple) left-turn lanes may be needed to maintain the desired level of service. For a double left-turn, a throat width of 30 to 36 feet is desirable on the exit leg of the turn to offset vehicle offtracking and the difficulty of two vehicles turning abreast. Use turn simulation software (such as AutoTURN<sup>®</sup>) to verify that the design vehicle can complete the turn. Where the design vehicle is a WB 40 or larger, it is desirable to provide for the design vehicle in the outside lane and an SU-30 vehicle turning abreast rather than two design vehicles turning abreast.

Exhibits [1310-10a](#) through [10f](#) show left-turn lane geometrics, which are described as follows:

#### 1. Widening

It is desirable that offsets and pavement widening (see [Exhibit 1310-10a](#)) be symmetrical about the centerline or baseline. Where right of way or topographic restrictions, crossroad alignments, or other circumstances preclude symmetrical widening, pavement widening may be on one side only.

#### 2. Divided Highways

Widening is not needed for left-turn lane channelization where medians are 11 feet wide or wider (see Exhibits [1310-10b](#) through [10d](#)). For medians between 13 feet and 23 feet or where the acceleration lane is not provided, it is desirable to design the left-turn lane adjacent to the opposing lane (see [Exhibit 1310-10b](#)) to improve sight distance and increase opposing left-turn clearances.

A median acceleration lane (see Exhibits [1310-10c](#) and [10d](#)) may be provided where the median is 23 feet or wider. The median acceleration lane might not be needed at a signalized intersection. When a median acceleration lane is to be used, design it in accordance with [1310.04\(4\)](#), Speed Change Lanes. Where medians have sufficient width, provide a 2-foot shoulder adjacent to a left-turn lane.

#### 3. Minimum Protected Left Turn With a Median

At intersections on divided highways where channelized left-turn lanes are not provided, provide the minimum protected storage area (see [Exhibit 1310-10e](#)).

#### 4. Modifications to Left-Turn Designs

With justification, the left-turn lane designs discussed above and given in Exhibits 1310-10a through 10e may be modified. Document the benefits and impacts of the modified design, including changes to vehicle-pedestrian conflicts; vehicle encroachment; deceleration length; capacity restrictions for turning vehicles or other degradation of intersection operations; and the effects on other traffic movements. Provide a modified design that is able to accommodate the design vehicle, and provide for the striping (see the *Standard Plans* and the MUTCD). Verify the design vehicle can make the turn using turn simulation software (such as AutoTURN®); include a plot of the design and verification.

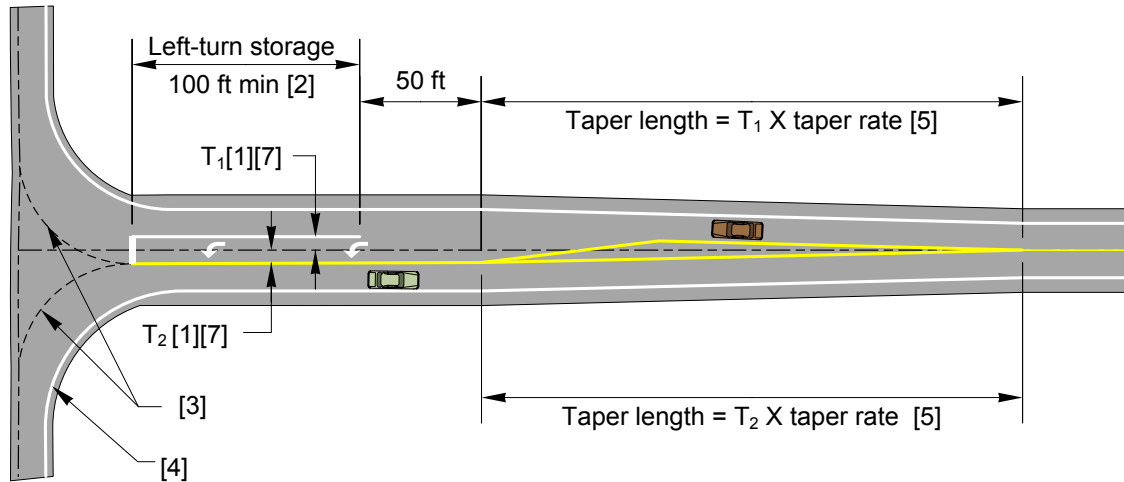

**Notes:**

- [1] The minimum width of the left-turn storage lane ( $T_1+T_2$ ) is 11 ft.
- [2] For left-turn storage length, see Exhibits 1310-7b for 4-lane roadways or 1310-8a through 8c for 2-lane roadways.
- [3] Use turn simulation software (such as AutoTURN®) to verify the design vehicle can make the turn.
- [4] For right-turn corner design, see Exhibit 1310-6.
- [5] For desirable taper rates, see Table on this Exhibit. With justification, taper rates from the Table in Exhibit 1310-10c may be used.
- [6] For pavement marking details, see the *Standard Plans* and the MUTCD.
- [7] When curb is provided, add the width of the curb and the shoulders to the left-turn lane width. For shoulder widths at curbs, see 1310.04(6) and Chapter 1240.

- $T_1$  = Width of left-turn lane on approach side of centerline
- $T_2$  = Width of left-turn lane on departure side of centerline

Posted Speed	Desirable Taper Rate [6]
55 mph	55:1
50 mph	50:1
45 mph	45:1
40 mph	40:1
35 mph	35:1
30 mph	30:1
25 mph	25:1

**Median Channelization: Widening**  
Exhibit 1310-10a

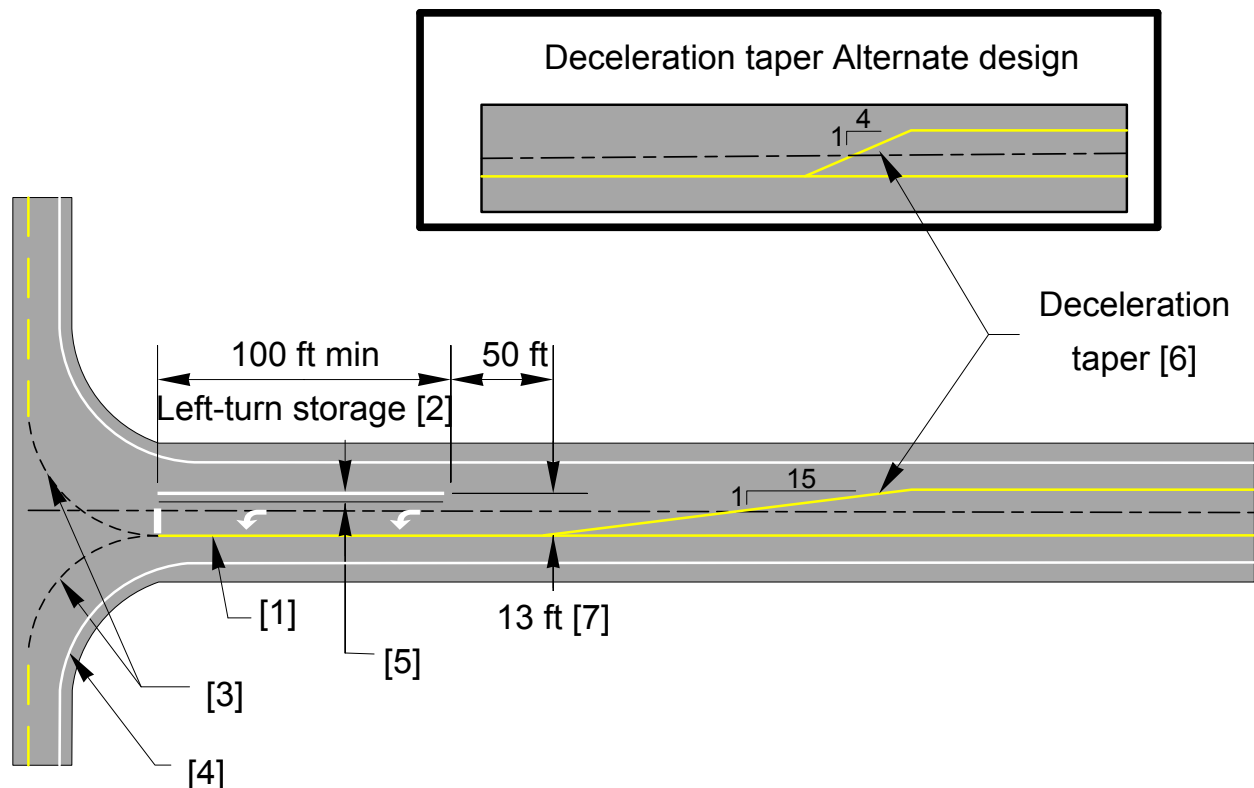
**Notes:**

- [1] When curb is provided, add the width of the curb and the shoulders. For shoulder widths at curbs, see [1310.04\(6\)](#) and [Chapter 1240](#).
- [2] For left-turn storage length, see Exhibits [1310-7b](#) for 4-lane roadways or [1310-8a](#) through [8c](#) for 2-lane roadways.
- [3] Verify the design vehicle can make the turn using turn simulation software (such as AutoTURN®).
- [4] For right-turn corner design, see [Exhibit 1310-6](#).
- [5] For median widths greater than 13 ft, it is desirable to locate the left-turn lane adjacent to the opposing through lane with excess median width between the same-direction through lane and the turn lane.
- [6] For increased storage capacity, the left-turn deceleration taper alternate design may be used.
- [7] Reduce to lane width for medians less than 13 ft wide.

**General:**

For pavement marking details, see the [Standard Plans](#) and the [MUTCD](#).

### Median Channelization: Median Width 11 ft or More

*Exhibit 1310-10b*

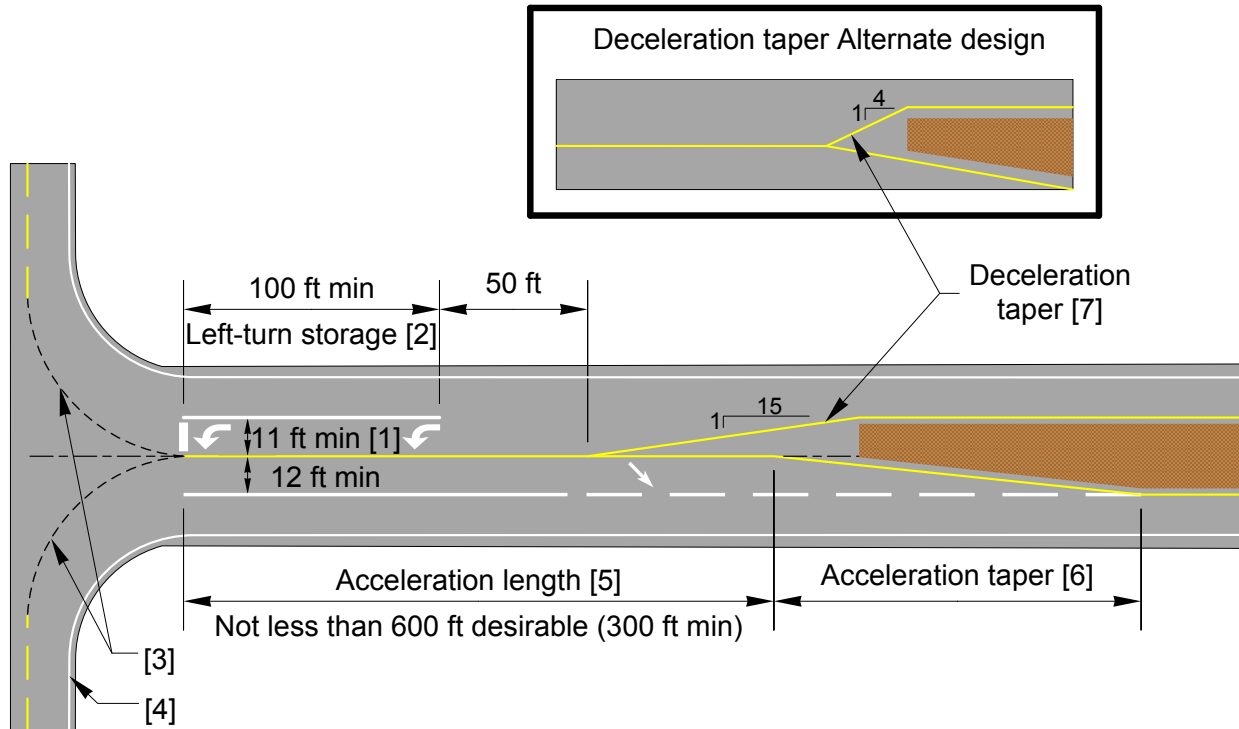

**Notes:**

- [1] When curb is provided, add the width of the curb.
- [2] For left-turn storage length, see Exhibits 1310-7b for 4-lane roadways or 1310-8a through 8c for 2-lane roadways.
- [3] Verify the design vehicle can make the turn using turn simulation software (such as AutoTURN®).
- [4] For right-turn corner design, see Exhibit 1310-6.
- [5] The minimum total length of the median acceleration lane is shown in Exhibit 1310-14.
- [6] For acceleration taper rate, see Table on this exhibit.
- [7] For increased storage capacity, the left-turn deceleration taper alternate design may be used.

Posted Speed	Taper Rate
55 mph	55:1
50 mph	50:1
45 mph	45:1
40 mph	27:1
35 mph	21:1
30 mph	15:1
25 mph	11:1

**General:**

For pavement marking details, see the *Standard Plans* and the *MUTCD*.

**Median Channelization: Median Width 23 ft to 26 ft**

*Exhibit 1310-10c*

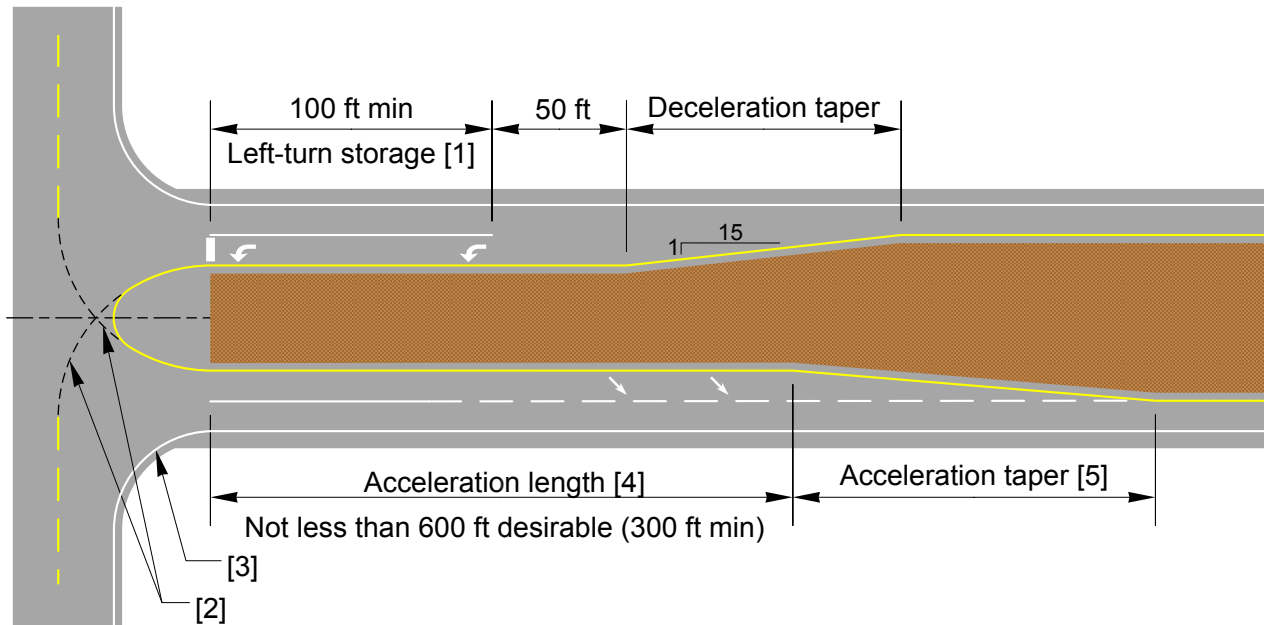
**Notes:**

- [1] For left-turn storage length, see Exhibits [1310-7b](#) for 4-lane roadways or [1310-8a](#) through [8c](#) for 2-lane roadways.
- [2] Verify the design vehicle can make the turn using turn simulation software (such as AutoTURN®).
- [3] For right-turn corner design, see [Exhibit 1310-6](#).
- [4] The minimum length of the median acceleration lane is shown in [Exhibit 1310-14](#).
- [5] For acceleration taper rate, see the Table on [Exhibit 1310-10c](#).

**General:**

For pavement marking details, see the [Standard Plans](#) and the [MUTCD](#).

**Median Channelization: Median Width of More Than 26 ft**  
*Exhibit 1310-10d*

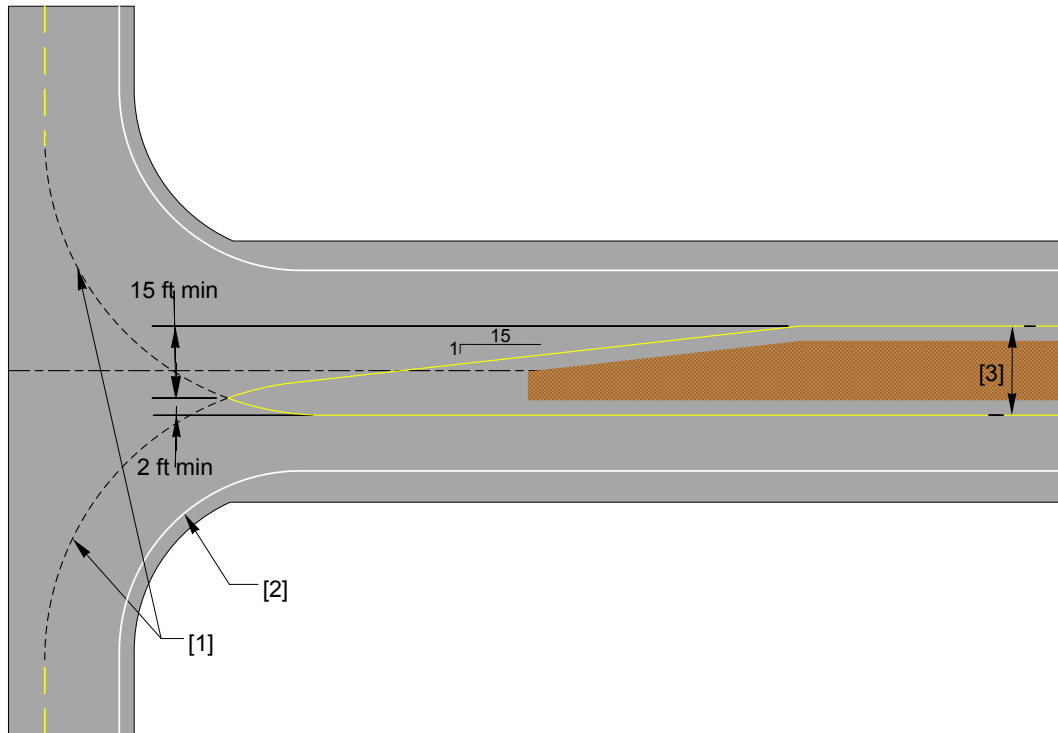
**Notes:**

- [1] Verify the design vehicle can make the turn using turn simulation software (such as AutoTURN®).
- [2] For right-turn corner design, see [Exhibit 1310-6](#).
- [3] For median width 17 ft or more. For median width less than 17 ft, widen to 17 ft. or use [Exhibit 1310-10b](#).

**General:**

For pavement marking details, see the [Standard Plans](#) and the [MUTCD](#).

### Median Channelization: Minimum Protected Storage

*Exhibit 1310-10e*

#### 1310.04(2)(b) Two-Way Left-Turn Lanes (TWLTL)

Two-way left-turn lanes are located between opposing lanes of traffic. They are used by vehicles making left turns from either direction, from or onto the roadway.

Use TWLTLs only on managed access highways where there are no more than two through lanes in each direction. Evaluate installation of TWLTLs where:

- A collision study indicates reduced crashes with a TWLTL.
- There are existing closely spaced access points or minor street intersections.
- There are unacceptable through traffic delays or capacity reductions because of left-turning vehicles.

TWLTLs can reduce delays to through traffic, reduce rear-end collisions, and provide separation between opposing lanes of traffic. However, they do not provide refuge for pedestrians and can encourage strip development with additional closely spaced access points. Evaluate other alternatives (such as prohibiting midblock left turns and providing for U-turns) before using a TWLTL. (See Chapters 1140 and 540 for additional restrictions on the use of TWLTLs.)

The basic design for a TWLTL is illustrated in [Exhibit 1310-10f](#). Additional criteria are as follows:

- The desirable length of a TWLTL is not less than 250 feet.
- Provide illumination in accordance with the guidelines in [Chapter 1040](#).
- Pavement markings, signs, and other traffic control devices must be in accordance with the [MUTCD](#) and the [Standard Plans](#).
- Provide clear channelization when changing from TWLTLs to one-way left-turn lanes at an intersection.

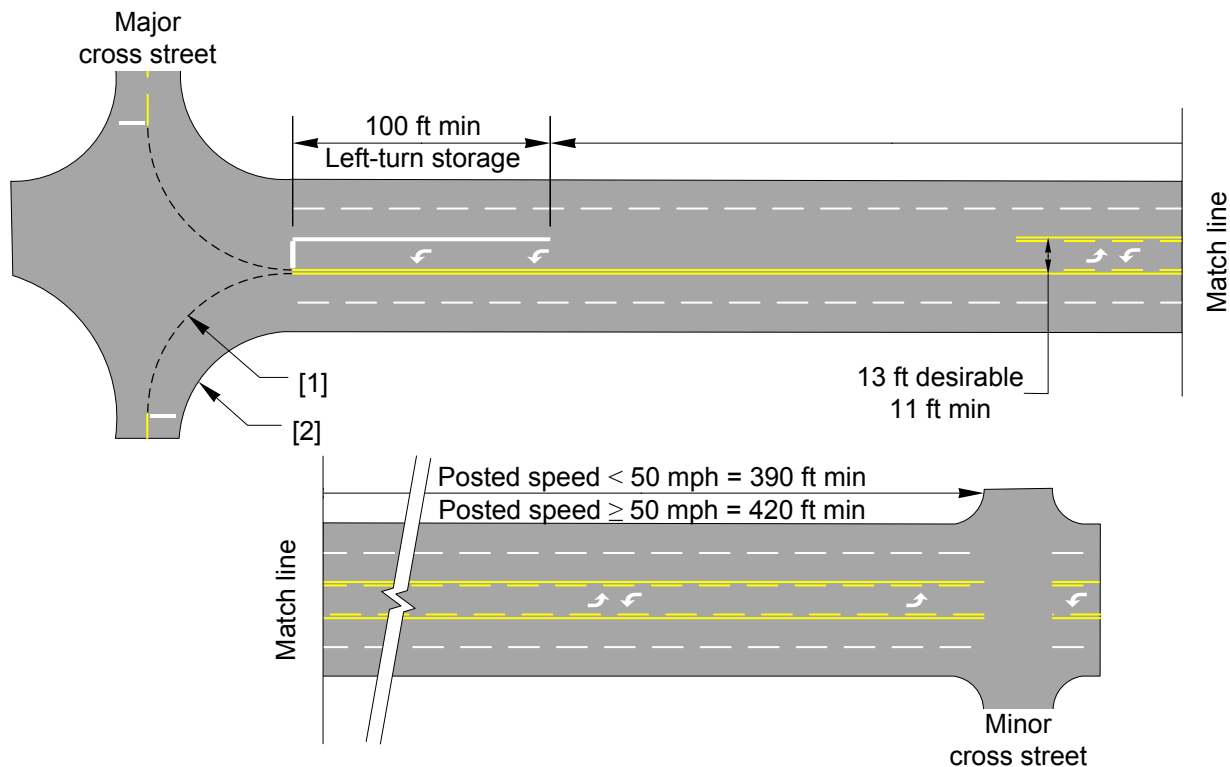

**Notes:**

- [1] Verify the design vehicle can make the turn using turn simulation software (such as AutoTURN®).  
 [2] For right-turn corner design, see [Exhibit 1310-6](#).

**General:**

For pavement marking details and signing criteria, see the [Standard Plans](#) and the [MUTCD](#).

**Median Channelization: Two-Way Left-Turn Lane**

*Exhibit 1310-10f*

### 1310.04(3) Right-Turn Lanes

Right-turn movements influence intersection capacity even though there is no conflict between right-turning vehicles and opposing traffic. Right-turn lanes might be needed to maintain efficient intersection operation. Use the following to determine when to consider right-turn lanes at unsignalized intersections:

- For two-lane roadways and for multilane roadways with a posted speed of 45 mph or above, when recommended by [Exhibit 1310-11](#).
- A collision study indicates an overall crash reduction with a right-turn lane.
- The presence of pedestrians requires right-turning vehicles to stop.
- Restrictive geometrics require right-turning vehicles to slow greatly below the speed of the through traffic.
- There is less than decision sight distance for traffic approaching the intersection.
- For unsignalized intersections, see [1310.04\(4\)](#) for guidance on right-turn lane lengths. For signalized intersections, use a traffic signal analysis to determine whether a right-turn lane is needed and what the length is (see [Chapter 1330](#)).
- A capacity analysis may be used to determine whether right-turn lanes are needed to maintain the desired level of service.
- Where adequate right of way exists, providing right-turn lanes is relatively inexpensive and can provide increased operational efficiency.
- The right-turn pocket or the right-turn taper (see [Exhibit 1310-12](#)) may be used at any minor intersection where a right-turn lane is not provided. These designs reduce interference and delay to the through movement by offering an earlier exit to right-turning vehicles.
- If the right-turn pocket is used, [Exhibit 1310-12](#) shows taper lengths for various posted speeds.

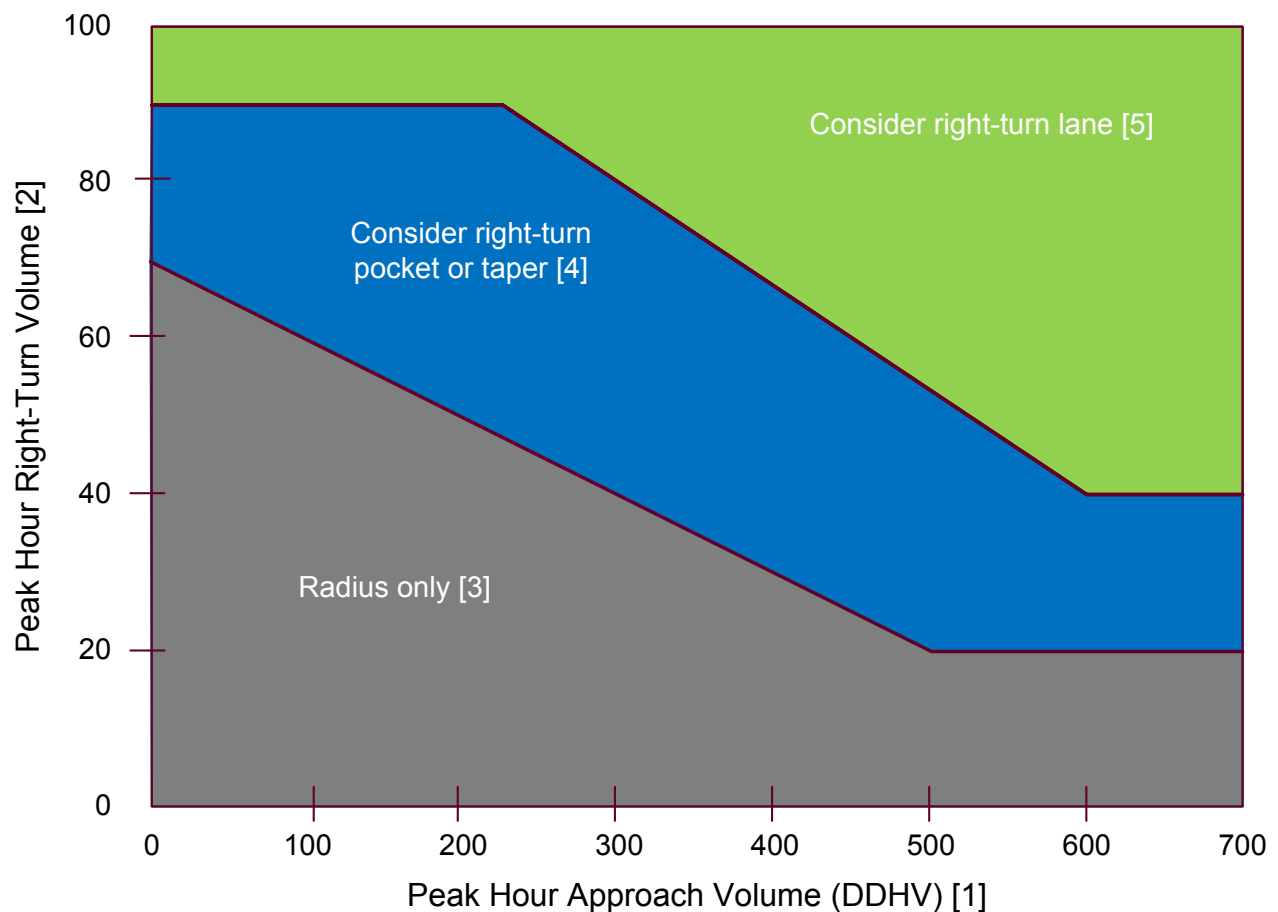

**Notes:**

- [1] For two-lane highways, use the peak hour DDHV (through + right-turn).  
For multilane, high-speed highways (posted speed 45 mph or above), use the right-lane peak hour approach volume (through + right-turn).
- [2] When all three of the following conditions are met, reduce the right-turn DDHV by 20:
- The posted speed is 45 mph or below
  - The right-turn volume is greater than 40 VPH
  - The peak hour approach volume (DDHV) is less than 300 VPH
- [3] For right-turn corner design, see [Exhibit 1310-6](#).
- [4] For right-turn pocket or taper design, see [Exhibit 1310-12](#).
- [5] For right-turn lane design, see [Exhibit 1310-13](#).

**Right-Turn Lane Guidelines**  
*Exhibit 1310-11*

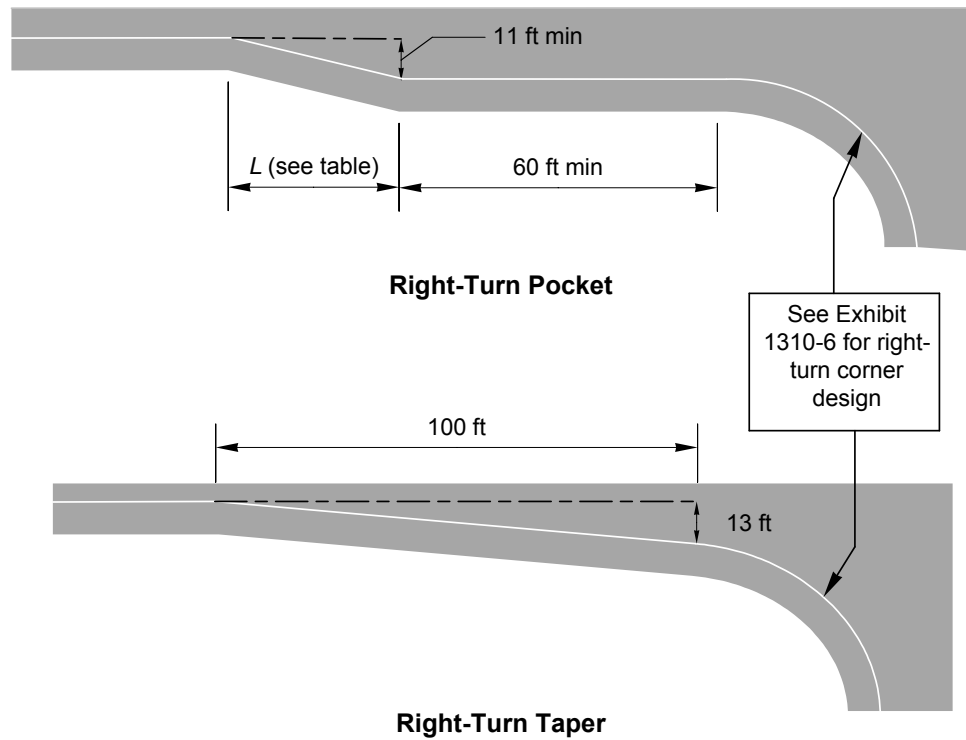

Posted Speed Limit	L
Below 40 mph	40 ft
40 mph or above	100 ft

**Right-Turn Pocket and Right-Turn Taper**

*Exhibit 1310-12*

**1310.04(4) Speed Change Lanes**

A speed change lane is an auxiliary lane primarily for the acceleration or deceleration of vehicles entering or leaving the through traveled way. Speed change lanes are normally provided for at-grade intersections on multilane divided highways with access control. Where roadside conditions and right of way allow, speed change lanes may be provided on other through roadways. Justification for a speed change lane depends on many factors, including speed; traffic volumes; capacity; type of highway; design and frequency of intersections and collision history

When either deceleration or acceleration lanes are to be used, design them in accordance with Exhibits 1310-13 and 1310-14. When the design speed of the turning traffic is greater than 20 mph, design the speed change lane as a ramp in accordance with Chapter 1360. When a deceleration lane is used with a left-turn lane, add the deceleration length to the storage length.

A dedicated deceleration lane (see Exhibit 1310-13) is advantageous because it removes slowing vehicles from the through lane.

An acceleration lane (see Exhibit 1310-14) is not as advantageous because entering drivers can wait for an opportunity to merge without disrupting through traffic. However, acceleration lanes for left-turning vehicles provide a benefit by allowing the turn to be made in two movements.

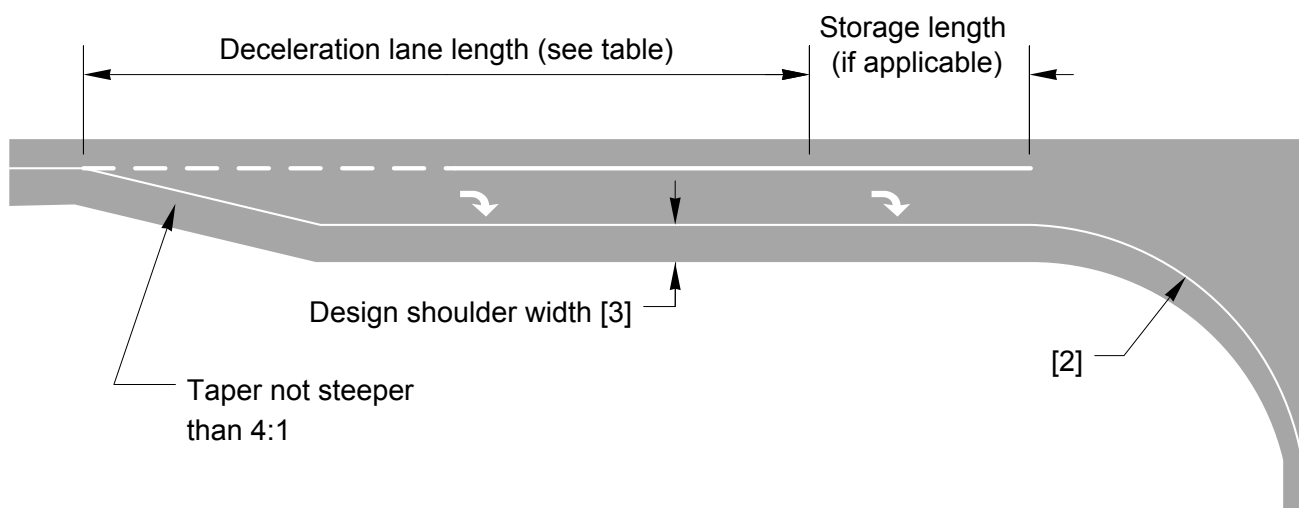

Highway Design Speed (mph)	Deceleration Lane Length (ft)
30	160 [1]
35	220
40	275
45	350
50	425
55	515
60	605
65	715
70	820

**Minimum Deceleration Lane Length (ft)**

Grade	Upgrade	Downgrade
3% to less than 5%	0.9	1.2
5% or more	0.8	1.35

**Adjustment Multiplier for Grades 3% or Greater**

**Notes:**

- [1] When adjusting for grade, do not reduce the deceleration lane to less than 150 ft.
- [2] For right-turn corner design, see [Exhibit 1310-6](#).
- [3] May be reduced (see [1310.04\(6\)](#)).

**General:**

For pavement marking details, see the [Standard Plans](#) and the [MUTCD](#).

**Right-Turn Lane**  
*Exhibit 1310-13*

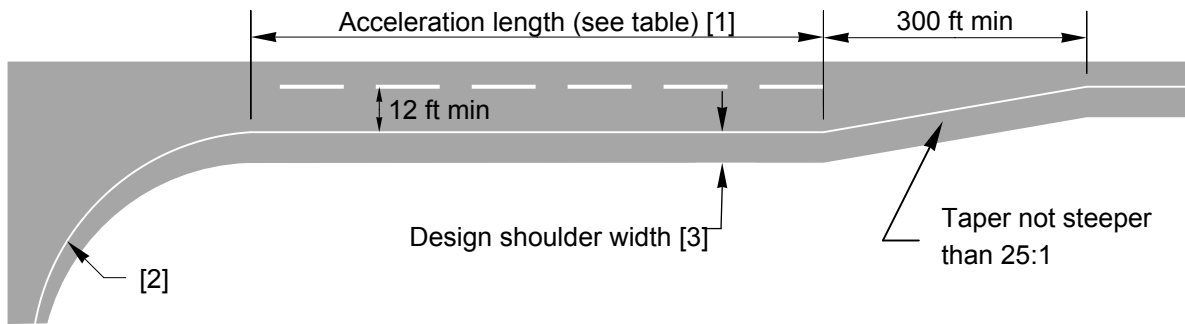

Highway Design Speed (mph)	Turning Roadway Design Speed (mph)		
	Stop	15	20
30	180	140	
35	280	220	160
40	360	300	270
45	560	490	440
50	720	660	610
55	960	900	810
60	1,200	1,140	1,100
65	1,410	1,350	1,310
70	1,620	1,560	1,520

Minimum Acceleration Length (ft) [1]

Highway Design Speed (mph)	% Grade	Upgrade	Downgrade
40	3% to less than 5%	1.3	0.7
50		1.3	0.65
60		1.4	0.6
70		1.5	0.6
40	5% or more	1.5	0.6
50		1.5	0.55
60		1.7	0.5
70		2.0	0.5

Adjustment Multiplier for Grades 3% or Greater

**Notes:**

[1] At free right turns (no stop required) and all left turns, the minimum acceleration lane length is not less than 300 ft.

[2] For right-turn corner design, see [Exhibit 1310-6](#).

[3] May be reduced (see [1310.04\(6\)](#)).

**General:**

For pavement-marking details, see the [Standard Plans](#) and the [MUTCD](#).

**Acceleration Lane**  
*Exhibit 1310-14*

### 1310.04(5) Drop Lanes

A lane may be dropped at an intersection with a turn-only lane or beyond the intersection. Do not allow a lane-reduction taper to cross an intersection or end less than 100 feet before an intersection. (See [Chapter 1210](#) for lane reduction pavement transitions.)

When a lane is dropped beyond signalized intersections, provide a lane of sufficient length to allow smooth merging. For facilities with a posted speed of 45 mph or higher, use a minimum length of 1,500 feet. For facilities with a posted speed lower than 45 mph, provide a lane of sufficient length that the advanced lane reduction warning sign can be placed not less than 100 feet beyond the intersection area.

When a lane is dropped beyond unsignalized intersections, provide a lane beyond the intersection not less than the acceleration lane length from [Exhibit 1310-14](#).

### 1310.04(6) Shoulders

With justification, shoulder widths may be reduced within areas channelized for intersection turning lanes or speed change lanes. Apply left shoulder width criteria to the median shoulder of divided highways. On one-way couplets, apply the width criteria for the right shoulder to both the right and left shoulders.

Reducing the shoulder width at intersections facilitates the installation of turn lanes without unduly affecting the overall width of the roadway. A narrower roadway also reduces pedestrian exposure in crosswalks and discourages motorists from using the shoulder to bypass other turning traffic.

For roadways without curb sections, the shoulder adjacent to turn lanes and speed change lanes may be reduced to 2 feet on the left and 4 feet on the right. When a curb and sidewalk section is used with a turn lane or speed change lane 400 feet or less in length, the shoulder abutting the turn lane may be eliminated. In instances where curb is used without sidewalk, provide a minimum of 4-foot-wide shoulders on the right. Where curbing is used adjacent to left-turn lanes, the shoulder may be eliminated. Adjust the design of the intersection as needed to allow for vehicle tracking.

On routes where provisions are made for bicycles, continue the bicycle facility between the turn lane and the through lane. (See [Chapter 1520](#) for information on bicycle facilities.)

### 1310.04(7) Islands

An island is a defined area within an intersection between traffic lanes for the separation of vehicle movements or for pedestrian refuge. Within an intersection, a median is considered an island. Design islands to clearly delineate the traffic channels to drivers and pedestrians.

Traffic islands perform the following functions:

- Channelization islands control and direct traffic movements.
- Divisional islands separate traffic movements.
- Refuge islands provide refuge for pedestrians and bicyclists crossing the roadway.
- Islands can provide for the placement of traffic control devices and luminaires.
- Islands can provide areas within the roadway for landscaping.

**1310.04(7)(a) Size and Shape**

Divisional islands are normally elongated and at least 4 feet wide and 20 feet long.

Channelization islands are normally triangular. In rural areas, 75 ft<sup>2</sup> is the minimum island area and 100 ft<sup>2</sup> is desirable. In urban areas where posted speeds are 25 mph or below, smaller islands are acceptable. Use islands with at least 200 ft<sup>2</sup> if pedestrians will be crossing or traffic control devices or luminaires will be installed.

Design triangular-shaped islands as shown in Exhibits [1310-15a](#) through [15c](#). The shoulder and offset widths illustrated are for islands with vertical curbs 6 inches or higher. Where painted islands are used, such as in rural areas, these widths are desirable but may be omitted. (See [Chapter 1240](#) for desirable turning roadway widths.)

Island markings may be supplemented with reflective raised pavement markers.

Provide barrier-free access at crosswalk locations where raised islands are used. For pedestrian refuge islands and barrier-free access requirements, see [Chapter 1510](#).

**1310.04(7)(b) Location**

Design the approach ends of islands so they are visible to motorists. Position the island so that a smooth transition in vehicle speed and direction is attained. Begin transverse lane shifts far enough in advance of the intersection to allow gradual transitions. Avoid introducing islands on a horizontal or vertical curve. If the use of an island on a curve cannot be avoided, provide sight distance, illumination, or extension of the island.

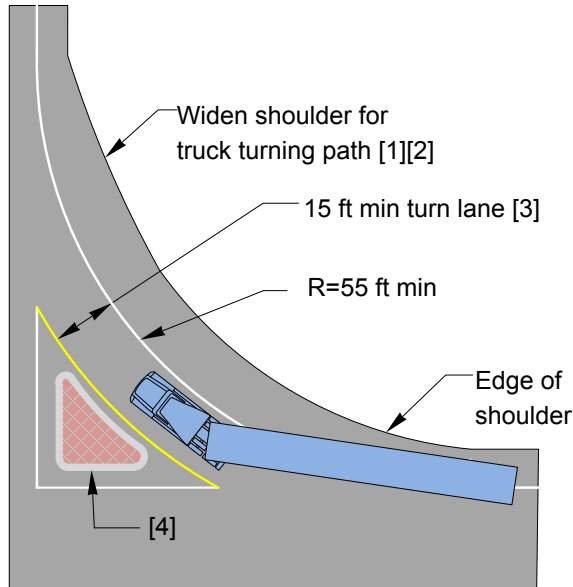

**Small Traffic Island Design [5]**

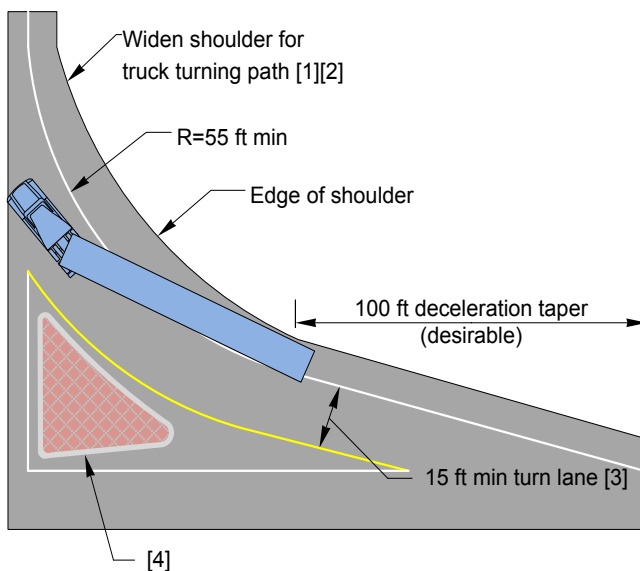

**Large Traffic Island Design [5]**

**Notes:**

- [1] Widen shoulders when right-turn radii or roadway width cannot be provided for large trucks. Design widened shoulder pavement the same depth as the right-turn lane.
- [2] Use turn simulation software (such as AutoTURN®) for the design vehicle and a minimum 2-ft clearance between the wheel paths and the face of curb or edge of shoulder to determine the width of the widened shoulder.
- [3] For desirable turning roadway widths, see [Chapter 1240](#).
- [4] For additional details on island placement, see [Exhibit 1310-15c](#).
- [5] Small traffic islands have an area of 100 ft<sup>2</sup> or less; large traffic islands have an area greater than 100 ft<sup>2</sup>.

**General:**

- Provide an accessible route for pedestrians (see [Chapter 1510](#)).
- 60° to 90° angle at stop or yield control.
- For right-turn corner design, see [Exhibit 1310-6](#).

**Traffic Island Designs**

*Exhibit 1310-15a*

**1310.04(7)(c) Compound Right-Turn Lane**

To design large islands, the common method is to use a large-radius curve for the turning traffic. While this does provide a larger island, it also encourages higher turning speeds. Where pedestrians are a concern, higher turning speeds are undesirable. An alternative is a compound curve with a large radius followed by a small radius (see [Exhibit 1310-15b](#)). This design forces the turning traffic to slow down.

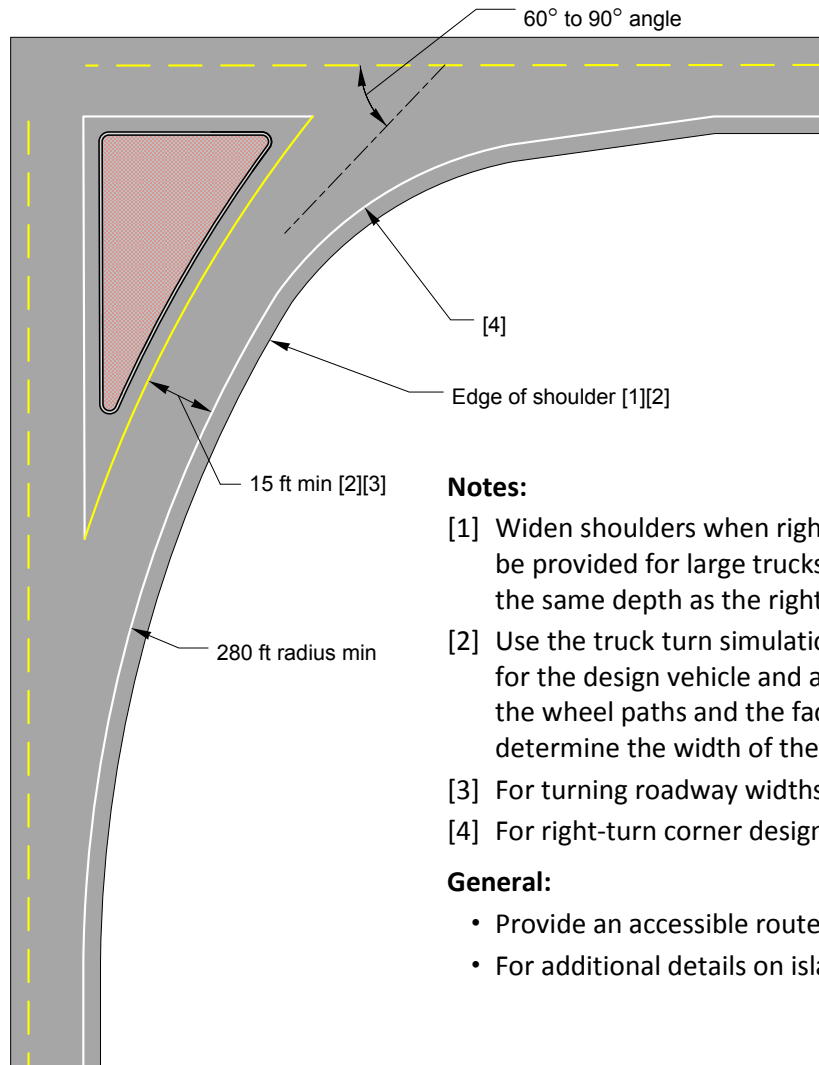
**Notes:**

- [1] Widen shoulders when right-turn radii and roadway width cannot be provided for large trucks. Design widened shoulder pavement the same depth as the right-turn lane.
- [2] Use the truck turn simulation software (such as AutoTURN®) for the design vehicle and a minimum 2-ft clearance between the wheel paths and the face of curb or edge of shoulder to determine the width of the widened shoulder.
- [3] For turning roadway widths, see [Chapter 1240](#).
- [4] For right-turn corner design, see [Exhibit 1310-6](#).

**General:**

- Provide an accessible route for pedestrians (see [Chapter 1510](#)).
- For additional details on island placement, see [Exhibit 1310-15c](#).

**Traffic Island Designs: Compound Curve**  
*Exhibit 1310-15b*

**1310.04(7)(d) Curbing**

Provide vertical curb 6 inches or higher for:

- Islands with luminaires, signals, or other traffic control devices.
- Pedestrian refuge islands.

Also consider curbing for:

- Divisional and channelizing islands.
- Landscaped islands.
- Stormwater conveyance.

In general, except to meet one of the uses listed above, it is desirable not to use curbs on facilities with a posted speed of 45 mph or above.

Avoid using curbs if the same objective can be attained with pavement markings.

Refer to [Chapter 1140](#) for additional information and design criteria on the use of curbs.



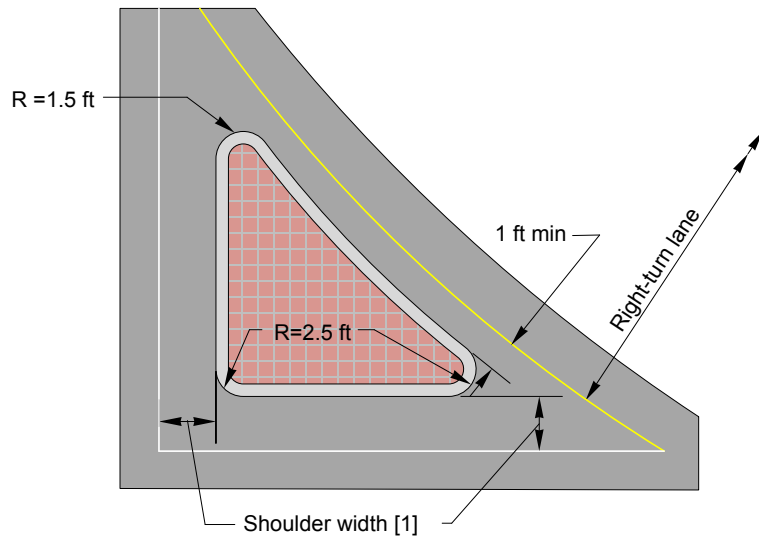

**Small Raised Traffic Island [2]**

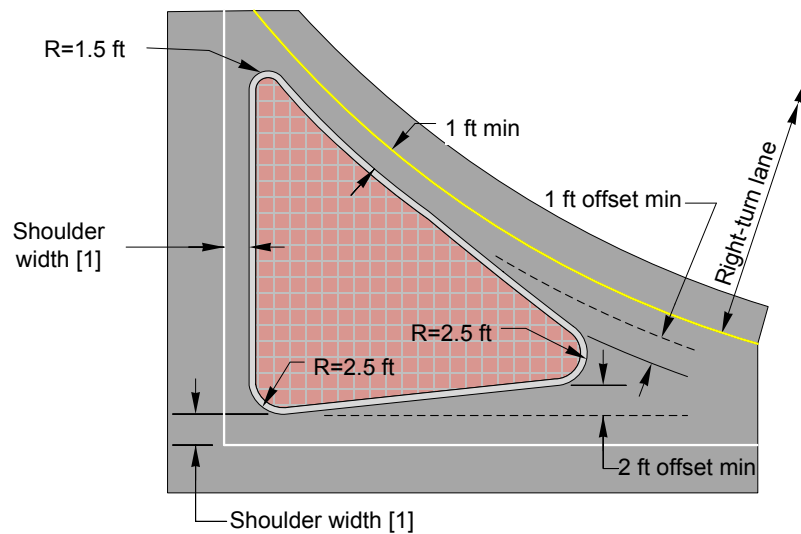

**Large Raised Traffic Island [2]**

**Notes:**

- [1] For minimum shoulder width at curbs, see [Chapter 1140](#). For additional information on shoulders at turn lanes, see [1310.04\(6\)](#).
- [2] Small traffic islands have an area of 100 ft<sup>2</sup> or less; large traffic islands have an area greater than 100 ft<sup>2</sup>.

**General:**

Provide an accessible route for pedestrians (see [Chapter 1510](#)).

**Traffic Island Designs**  
*Exhibit 1310-15c*

### 1310.05 U-Turns

For divided multilane highways without full access control that have access points where the median prevents left turns, evaluate the demand for locations that allow U-turns. Normally, U-turn opportunities are provided at intersections. However, where intersections are spaced far apart, U-turn median openings may be provided between intersections to accommodate U-turns. Use the desirable U-turn spacing (see [Exhibit 1310-16](#)) as a guide to determine when to provide U-turn median openings between intersections. Where the U-turning volumes are low, longer spacing may be used.

Locate U-turn median openings where intersection sight distance can be provided.

Urban/Rural	Desirable	Minimum
Urban [1]	1,000 ft	[2]
Suburban	½ mile	¼ mile [3]
Rural	1 mile	½ mile

**Notes:**

[1] For design speeds higher than 45 mph, use suburban spacing.

[2] The minimum spacing is the acceleration lane length from a stop (see [Exhibit 1310-14](#)) plus 300 ft.

[3] For design speeds 60 mph or higher, the minimum spacing is the acceleration lane length from a stop (see [Exhibit 1310-14](#)) plus 300 ft.

#### U-Turn Spacing *Exhibit 1310-16*

When designing U-turn median openings, use [Exhibit 1310-18](#) as a guide. Where the median is less than 40 feet wide, with a large design vehicle, provide a U-turn roadway (see [Exhibit 1310-17](#)). Design A, with the U-turn roadway after the left-turn, is desirable. Use Design A when the median can accommodate a left-turn lane. Use Design B only where left-turn channelization cannot be built in the median.

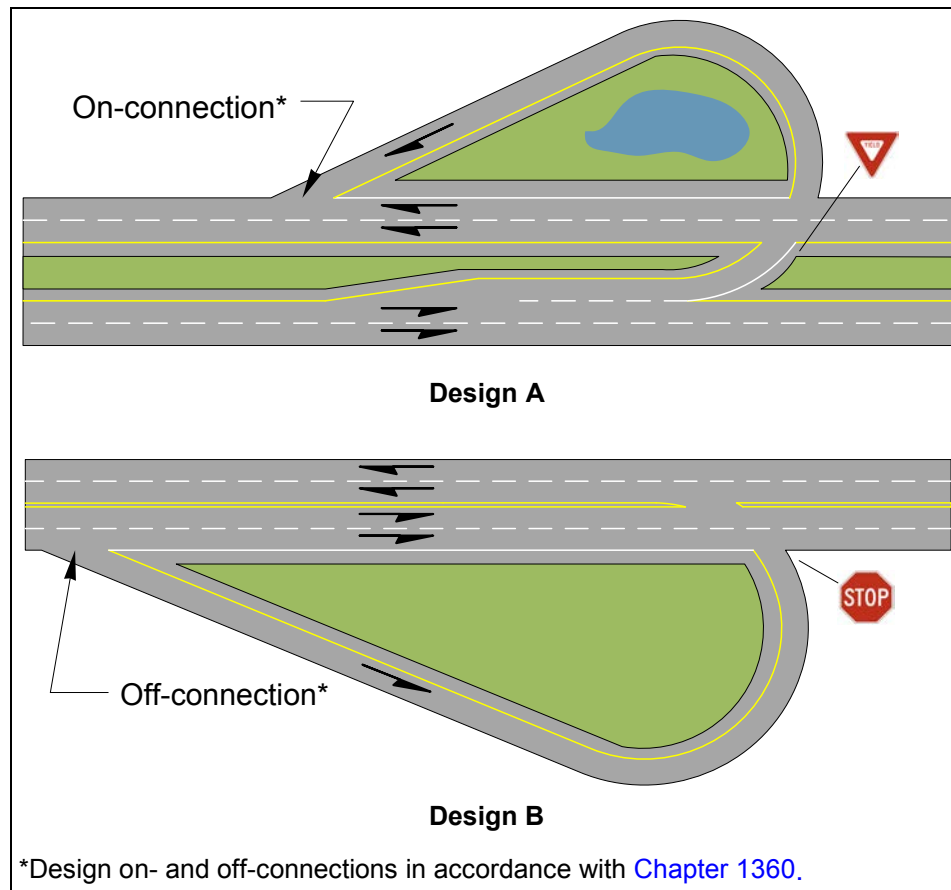

### U-Turn Roadway Exhibit 1310-17

Document the need for U-turn locations, the spacing used, and the selected design vehicle. If the design vehicle is smaller than the largest vehicle using the facility, provide an alternate route.

U-turns at signal-controlled intersections do not need the acceleration lanes shown in [Exhibit 1310-18](#). For new U-turn locations at signal-controlled intersections, evaluate conflicts between right-turning vehicles from side streets and U-turning vehicles. Warning signs on the cross street might be appropriate.

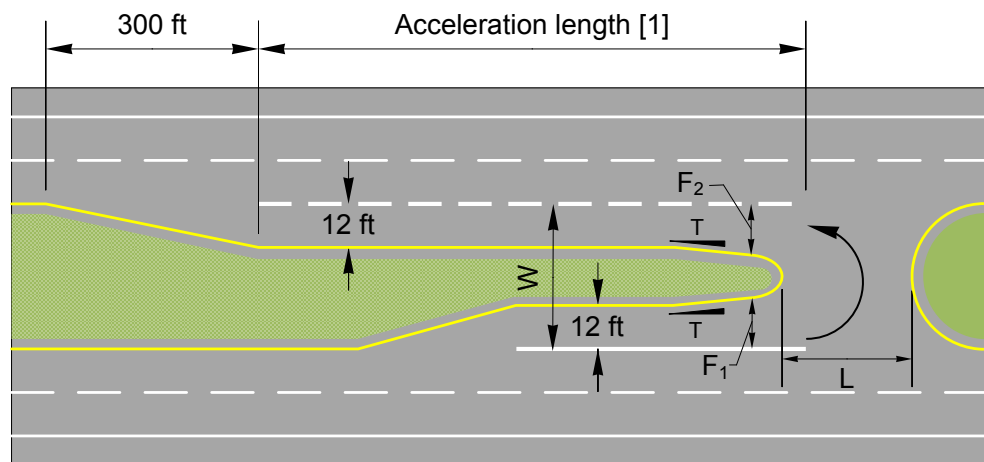
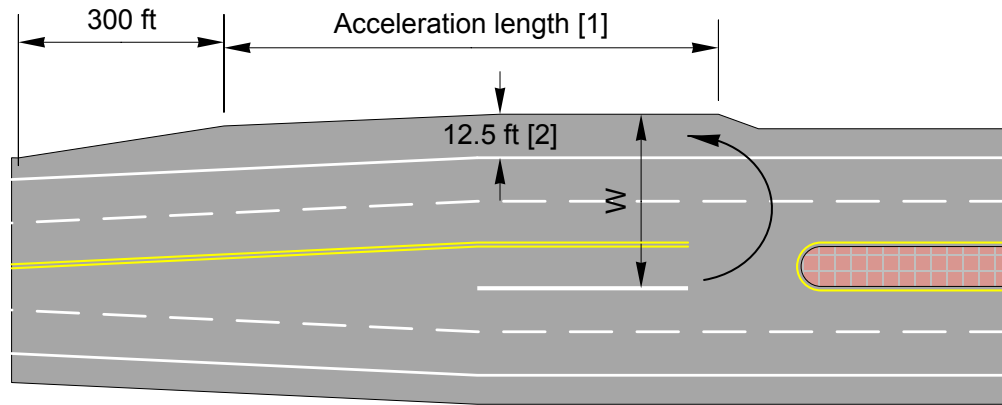

Vehicle	W	R	L	F <sub>1</sub>	F <sub>2</sub>	T
P	52	14	14	12	12	—
SU-30	87	30	20	13	15	10:1
CITY-BUS	87	28	23	14	18	10:1
WB-40	84	25	27	15	20	6:1
WB-67	94	22	49	15	35	6:1

**U-Turn Design Dimensions**

**Notes:**

- [1] The minimum length of the acceleration lane is shown in [Exhibit 1310-14](#). Acceleration lane may be eliminated at signal-controlled intersections.
- [2] When U-turn uses the shoulder, provide 12.5-ft shoulder width and shoulder pavement designed to the same depth as the through lanes for the acceleration length and taper.

**General:**

All dimensions are in feet.

**U-Turn Median Openings**  
*Exhibit 1310-18*

## 1310.06 Intersection Sight Distance

Providing drivers the ability to see stop signs, traffic signals, and oncoming traffic in time to react accordingly will reduce the probability of conflicts occurring at an intersection. Actually avoiding conflicts is dependent on the judgment, abilities, and actions of all drivers using the intersection.

The driver of a vehicle that is stopped and waiting to cross or enter a through roadway needs obstruction-free sight triangles in order to see enough of the through roadway to complete all legal maneuvers before an approaching vehicle on the through roadway can reach the intersection. Use [Exhibit 1310-19a](#) to determine minimum intersection sight distance along the through roadway.

The sight triangle is determined as shown in [Exhibit 1310-19b](#). Within the sight triangle, lay back the cut slopes and remove, lower, or move hedges, trees, signs, utility poles, signal poles, and anything else large enough to be a sight obstruction. Eliminate parking to remove obstructions to sight distance. In order to maintain the sight distance, the sight triangle must be within the right of way or a state maintenance easement (see [Chapter 510](#)).

The setback distance for the sight triangle is 18 feet from the edge of traveled way. This is for a vehicle stopped 10 feet from the edge of traveled way. The driver is almost always 8 feet or less from the front of the vehicle; therefore, 8 feet are added to the setback. When the stop bar is placed more than 10 feet from the edge of traveled way, providing the sight triangle to a point 8 feet back of the stop bar is desirable.

Provide a clear sight triangle for a P vehicle at all intersections. In addition, provide a clear sight triangle for the SU-30 vehicle for rural highway conditions. If there is significant combination truck traffic, use the WB-67 rather than the SU-30. In areas where SU-30 or WB vehicles are minimal and right of way restrictions limit sight triangle clearing, only the P vehicle sight distance needs to be provided.

At existing intersections, when sight obstructions within the sight triangle cannot be removed due to limited right of way, the intersection sight distance may be modified. Drivers who do not have the desired sight distance creep out until the sight distance is available; therefore, the setback may be reduced to 10 feet. Document the right of way width and provide a brief analysis of the intersection sight distance clarifying the reasons for reduction. Verify and document that there is no identified collision trend at the intersection. Document the intersection location and the available sight distance in the Design Variance Inventory (see [Chapter 300](#)) as a design exception.

If the intersection sight distance cannot be provided using the reductions in the preceding paragraph, where stopping sight distance is provided for the major roadway, the intersection sight distance, at the 10-foot setback point, may be reduced to the stopping sight distance for the major roadway, with an evaluate upgrade and HQ Design Office review and concurrence. (See [Chapter 1260](#) for required stopping sight distance.) Document the right of way width and provide a brief analysis of the intersection sight distance clarifying the reasons for reduction. Verify and document that there is no identified collision trend at the intersection. Document the intersection location and the available sight distance in the Design Variance Inventory (see [Chapter 300](#)) as an evaluate upgrade.

In some instances, intersection sight distance is provided at the time of construction, but subsequent vegetative growth has degraded the sight distance available. The growth may be seasonal or occur over time. In these instances, intersection sight distance can be restored through the periodically scheduled maintenance of vegetation in the sight triangle within the WSDOT right of way or state maintenance easement.

At intersections controlled by traffic signals, provide sight distance for right-turning vehicles. For intersections controlled by the geometry of roundabouts, see [Chapter 1320](#).

Designs for movements that cross divided highways are influenced by median widths. If the median is wide enough to store the design vehicle, with a 3-foot clearance at both ends of the vehicle, sight distances are determined in two steps. The first step is for crossing from a stopped position to the median storage. The second step is for the movement, either across or left into the through roadway.

Design sight distance for ramp terminals as at-grade intersections with only left- and right-turning movements. An added element at ramp terminals is the grade separation structure. [Exhibit 1310-19b](#) gives the sight distance guidance in the vicinity of a structure. In addition, when the crossroad is an undercrossing, check the sight distance under the structure graphically using a truck eye height of 6 feet and an object height of 1.5 feet.

Document a brief description of the intersection area, sight distance restrictions, and traffic characteristics to support the design vehicle and sight distances chosen.

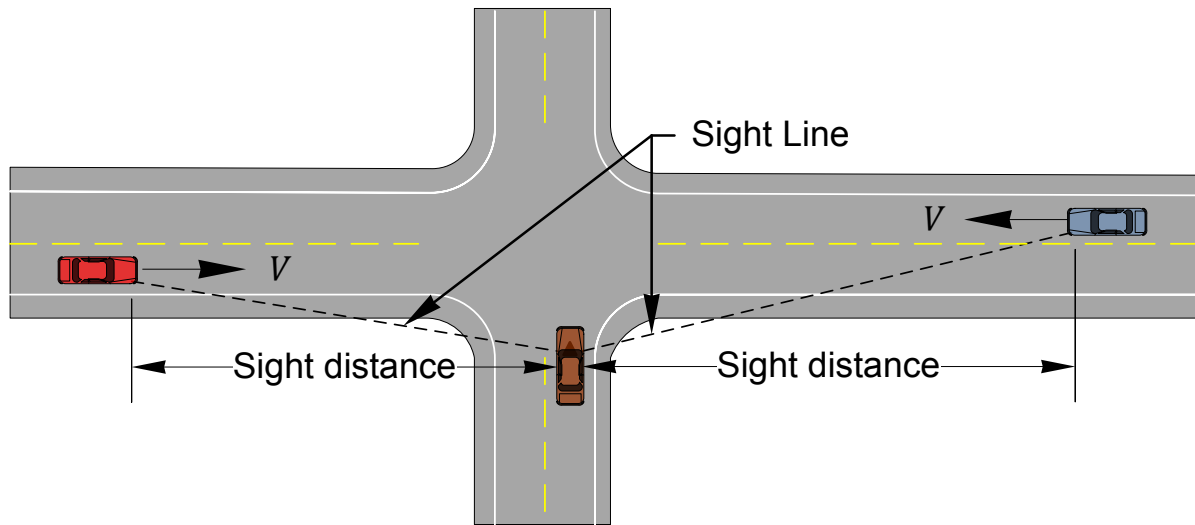

$$S_i = 1.47Vt_g$$

**Where:**  
 $S_i$  = Intersection sight distance (ft)  
 $V$  = Design speed of the through roadway (mph)  
 $t_g$  = Time gap for the minor roadway traffic to enter or cross the through roadway (sec)

**Intersection Sight Distance Equation**

Table 1

Design Vehicle	Time Gap ( $t_g$ ) in Sec
Passenger car (P)	7.5
Single-unit trucks and buses (SU-30 & CITY-BUS)	9.5
Combination trucks (WB-40 & WB-67)	11.5

**Note:**

Values are for a stopped vehicle to turn left onto a two-lane two-way roadway with no median and grades 3% or less.

**Intersection Sight Distance Time Gaps ( $t_g$ )**

Table 2

Adjust the  $t_g$  values listed in Table 2 as follows:

**Crossing or right-turn maneuvers:**

All vehicles subtract 1.0 sec

**Multilane roadways:**

Left turns, for each lane in excess of one to be crossed, and for medians wider than 4 ft:

Passenger cars add 0.5 sec

All trucks and buses add 0.7 sec

Crossing maneuvers, for each lane in excess of two to be crossed, and for medians wider than 4 ft:

Passenger cars add 0.5 sec

All trucks and buses add 0.7 sec

**Note:** Where medians are wide enough to store the design vehicle, determine the sight distance as two maneuvers.

**Crossroad grade greater than 3%:**

All movements upgrade for each percent that exceeds 3%:

All vehicles add 0.2 sec

**Sight Distance at Intersections**

Exhibit 1310-19a

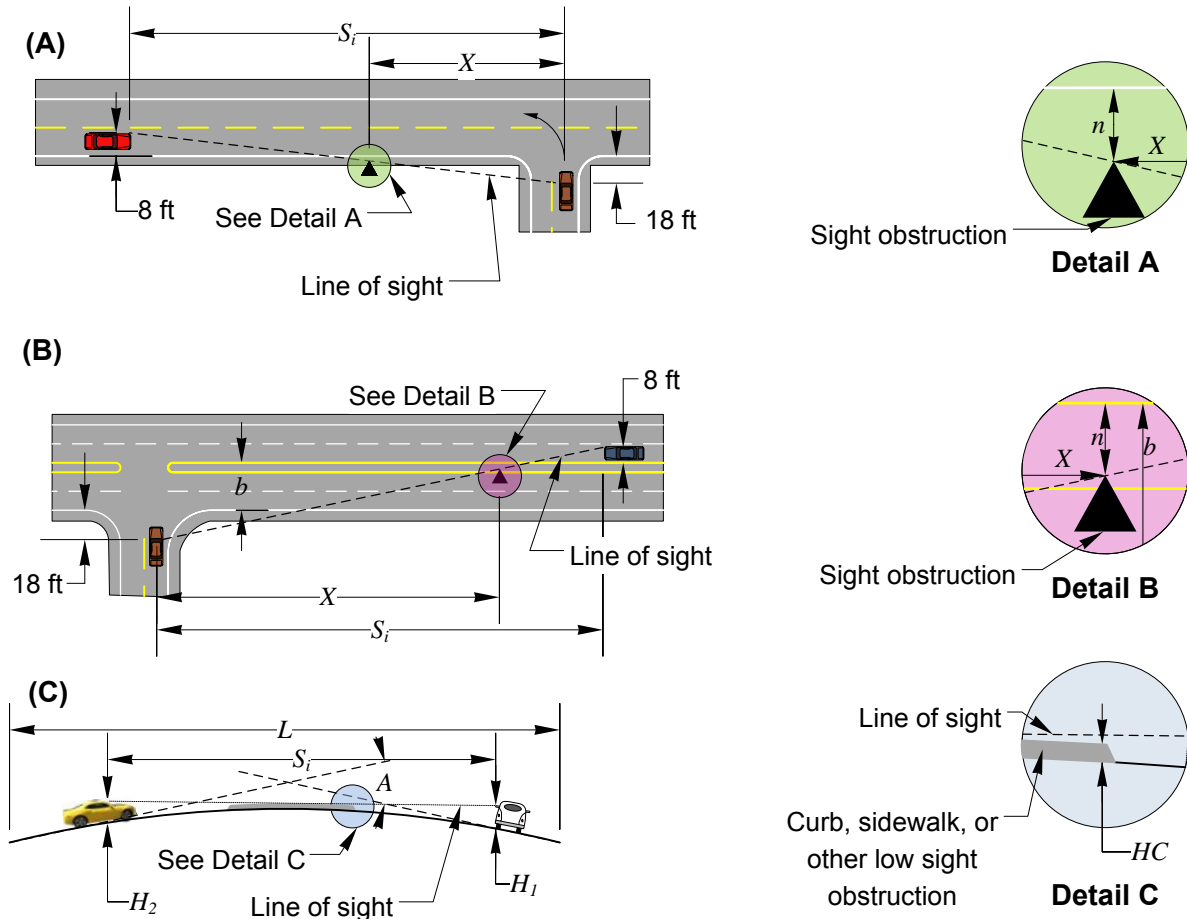

For sight obstruction driver cannot see over:

$$S_i = \frac{(26 + b)(X)}{(18 + b - n)}$$

Where:

- $S_i$  = Available intersection sight distance (ft)
- $n$  = Offset from sight obstruction to edge of lane (ft)
- $b$  = Distance from near edge of traveled way to near edge of lane approaching from right (ft) ( $b=0$  for sight distance to the left)
- $X$  = Distance from centerline of lane to sight obstruction (ft)

For crest vertical curve over a low sight obstruction when  $S < L$ :

$$S_i = \sqrt{\frac{100L[\sqrt{2(H_1 - HC)} + \sqrt{2(H_2 - HC)}]^2}{A}}$$

$$L = \frac{AS_i^2}{100[\sqrt{2(H_1 - HC)} + \sqrt{2(H_2 - HC)}]^2}$$

Where:

- $S_i$  = Available sight distance (ft)
- $H_1$  = Eye height (3.5 ft for passenger cars; 6 ft for all trucks)
- $H_2$  = Approaching vehicle height (3.5 ft)
- $HC$  = Sight obstruction height (ft)
- $L$  = Vertical curve length (ft)
- $A$  = Algebraic difference in grades (%)

### Sight Distance at Intersections

Exhibit 1310-19b



## 1310.07 Signing and Delineation

Use the [MUTCD](#) and the [Standard Plans](#) for signing and delineation criteria. Provide a route confirmation sign on all state routes shortly after major intersections. (See [Chapter 1020](#) for additional information on signing.)

Painted or plastic pavement markings are normally used to delineate travel paths. For pavement marking details, see the [MUTCD](#), [Chapter 1030](#), and the [Standard Plans](#).

Contact the region or HQ Traffic Office for additional information when designing signing and pavement markings.

## 1310.08 Procedures

Document design decisions and conclusions in accordance with [Chapter 300](#). For highways with limited access control, see [Chapter 530](#).

### 1310.08(1) Approval

An intersection is approved in accordance with [Chapter 300](#). Complete the following items, as needed, before intersection approval:

- [Intersection Control Type Approval](#) (see [Chapter 1300](#))
- Deviations approved in accordance with [Chapter 300](#)
- Approved Traffic Signal Permit (DOT Form 242-014 EF) (see [Chapter 1330](#))

### 1310.08(2) Intersection Plans

Provide intersection plans for any increases in capacity (turn lanes) at an intersection, modification of channelization, or change of intersection geometrics. Support the need for intersection or channelization modifications with history; school bus and mail route studies; hazardous materials route studies; pedestrian use; public meeting comments; [etc.](#)

For information to be included on the intersection plan for approval, see the Intersection/Channelization Plan for Approval Checklist on the following website:

[www.wsdot.wa.gov/design/projectdev/](http://www.wsdot.wa.gov/design/projectdev/)

### 1310.08(3) Local Agency or Developer-Initiated Intersections

Intersections in local agency and developer projects on state routes must receive the applicable approvals in section [1310.08\(1\)](#) as part of the intersection design process.

The project initiator submits an intersection plan and the documentation of design decisions that led to the plan to the region for approval. For those plans requiring a design variance, the deviation or evaluate upgrade must be approved in accordance with [Chapter 300](#) prior to approval of the plan. After the plan approval, the region prepares a construction agreement with the project initiator (see the [Utilities Manual](#)).

## 1310.09 Documentation

Refer to [Chapter 300](#) for design documentation requirements.



- 1320.01 General
- 1320.02 References
- 1320.03 Roundabout Types
- 1320.04 Capacity Analysis
- 1320.05 Geometric Design
- 1320.06 Pedestrians
- 1320.07 Bicycles
- 1320.08 Signing and Pavement Marking
- 1320.09 Illumination
- 1320.10 Road Approach, Parking, and Transit Facilities
- 1320.11 Approvals
- 1320.12 Documentation

## 1320.01 General

Modern roundabouts are near-circular intersections at grade. They are an effective intersection type with fewer conflict points and lower speeds, and they provide for easier decision making than conventional intersections. They also require less maintenance than traffic signals. Well-designed roundabouts have been found to reduce crashes (especially fatal and severe injury collisions), traffic delays, fuel consumption, and air pollution. They also have a traffic-calming effect by reducing vehicle speeds using geometric design rather than relying solely on traffic control devices.

Roundabout design is an iterative process. A well-designed roundabout achieves a balance of safety and efficiency. Good design is a process of creating the smooth curvature, channelization, and deflection required to achieve consistent speeds, well-marked lane paths, and appropriate sight distance.



The guidance in this chapter assumes that a roundabout-type intersection has been determined to be the best intersection design for your particular project based on the process completed in [Chapter 1300](#).

## 1320.02 References

### 1320.02(1) Federal/State Laws and Codes

Americans with Disabilities Act of 1990 (ADA)

[Revised Code of Washington \(RCW\) 47.05.021](#), Functional classification of highways

[Washington Administrative Code \(WAC\) 468-58-080](#), Guides for control of access on crossroads and interchange ramps

### 1320.02(2) Design Guidance

*ADA Standards for Accessible Design*, U.S. Department of Justice

<http://www.ada.gov/>

*Local Agency Guidelines* (LAG), M 36-63, WSDOT

*Manual on Uniform Traffic Control Devices for Streets and Highways*, USDOT, FHWA, as adopted and modified by Chapter [468-95 WAC](#) “Manual on uniform traffic control devices for streets and highways” (MUTCD)

Revised Draft Guidelines for Accessible Public Rights-of-Way (PROWAG), November 23, 2005, U.S. Access Board. The current best practices for evaluation and design of pedestrian facilities in the public right of way per the following FHWA Memoranda:

<http://www.access-board.gov/prowac/draft.htm>

*Standard Plans for Road, Bridge, and Municipal Construction (Standard Plans)*, M 21-01, WSDOT

*Standard Specifications for Road, Bridge, and Municipal Construction (Standard Specifications)*, M 41-10, WSDOT

### 1320.02(3) Supporting Information

*A Policy on Geometric Design of Highways and Streets* (Green Book), AASHTO

“Crash Reductions Following Installation of Roundabouts in the United States,” Insurance Institute for Highway Safety, March 2000

[https://www.dot.ny.gov/main/roundabouts/files/insurance\\_report.pdf](https://www.dot.ny.gov/main/roundabouts/files/insurance_report.pdf)

*Roundabouts: An Informational Guide*, NCHRP Report 672, Transportation Research Board, 2010

*Roundabouts in the United States*, NCHRP Synthesis 572, Transportation Research Board, 2007

*Highway Capacity Manual* (HCM), Special Report 209, Transportation Research Board, National Research Council

*Modern Roundabout Practice in the United States*, NCHRP Synthesis 264, Transportation Research Board, 1998

[http://onlinepubs.trb.org/onlinepubs/nchrp/nchrp\\_syn\\_264.pdf](http://onlinepubs.trb.org/onlinepubs/nchrp/nchrp_syn_264.pdf)

*Roundabouts: An Informational Guide*, FHWA-RD-00-067, USDOT, FHWA

<http://www.fhwa.dot.gov/publications/research/safety/00067/index.cfm>

Understanding Flexibility in Transportation Design – Washington, WSDOT, 2005

[www.wsdot.wa.gov/research/reports/600/638.1.htm](http://www.wsdot.wa.gov/research/reports/600/638.1.htm)

### 1320.03 Roundabout Types

There are four basic roundabout types: mini, single-lane, multilane, and teardrop.

#### 1320.03(1) *Mini-Roundabouts*

Mini-roundabouts are small single-lane roundabouts generally used in 25 mph or less urban/suburban environments. Because of this, mini-roundabouts are typically not suitable for use on higher-volume (greater than 6,000 AADT) state routes. In retrofit applications, mini-roundabouts are relatively inexpensive because they normally require minimal additional pavement at the intersecting roads. A 2-inch mountable curb for the splitter islands and the central island is desirable because larger vehicles might be required to cross over it.

A common application is to replace a stop-controlled or uncontrolled intersection with a mini-roundabout to reduce delay and increase capacity. With mini roundabouts, the existing curb and sidewalk at the intersection can sometimes be left in place.



#### 1320.03(2) *Single-Lane Roundabouts*

Single-lane roundabouts have single-lane entries at all legs and one circulating lane. They typically have mountable raised splitter islands, a mountable truck apron, and a central island, which is typically landscaped.



### 1320.03(3) *Multilane Roundabouts*

Multilane roundabouts have at least one entry or exit with two or more lanes and more than one circulating lane. The operational practice for trucks negotiating roundabouts is to encroach on adjacent lanes.



### 1320.03(4) *Teardrop Roundabout*

Teardrops are usually associated with ramp terminals at interchanges: typically, at diamond interchanges. Teardrop roundabouts allow the “wide node, narrow link” concept. Unlike circular roundabouts, teardrops do not allow for continuous 360° travel. This design offers some advantages at interchanges. Traffic traveling on the crossroad (link) between ramp terminal intersections (nodes) does not encounter a yield as it enters the teardrop intersections. Because this improves traffic throughput on the crossroad between the ramps, it reduces the need for additional lane capacity, thus keeping the cross section between the ramp terminals as narrow as possible.



## 1320.04 Capacity Analysis

Use the capacity analysis that was completed as part of the Intersection Control Analysis (see [Chapter 1300](#)) to verify the number of lanes required for every individual movement in the design year.

## 1320.05 Geometric Design

### 1320.05(1) Selecting Shape and Location

Roundabout shape is one of the most important decisions a designer makes, because the shape can affect design elements that affect safety performance and operation of the roundabout. The desirable shape of a roundabout is circular. But sometimes a circular shape is not feasible because of specific needs or constraints; in which case, consider a noncircular shape. Sometimes a circular shape can still be used by slightly offsetting the roundabout. The designer needs to understand the actual constraints and needs.



#### 1320.05(1)(a) Circular

The circular shape is the most desirable roundabout shape to be used when constraints allow. If a circular shape is not feasible, contact the region Traffic Office to investigate other shapes.

#### 1320.05(1)(b) Oval (elliptical)

An oval or elliptical roundabout is a good choice when constraints such as right of way, existing roadway alignments, buildings, and/or wetlands influence the shape. The designer should experiment with different roundabout sizes and radii, and use the design vehicle turning software (such as AutoTURN<sup>®</sup>) to refine the oval shape to find the best operation while retaining lower speeds.

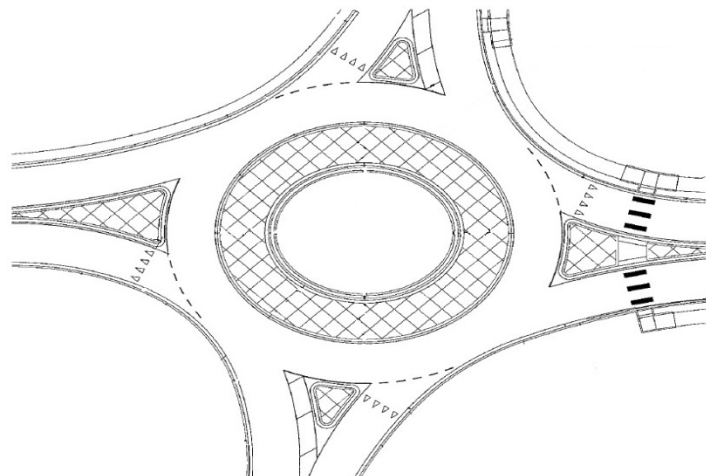

**1320.05(1)(c) Racetrack**

The racetrack is a successful shape when the main line right of way is very constrained and driveways are attached to the circulating roadway. Special care is needed to design the deflection and travel paths to keep entrance and circulating speeds acceptable for a roundabout.



**1320.05(2) Roundabout Elements**

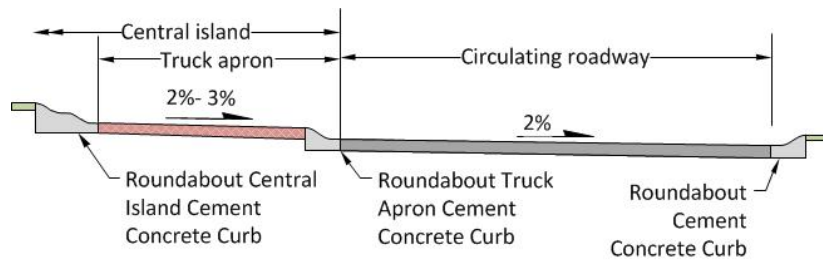



**1320.05(2)(a) Circulatory Roadway**

The selection of the circulation roadway radius is important because it defines the base speed of the roundabout. The design vehicle turning path and width of the entries determine the circulatory roadway.

**1320.05(2)(b) Truck Apron**

A truck apron will be wider, or narrower, based on the needs of the design vehicle. Using turn simulation software (such as AutoTURN<sup>®</sup>) allows a designer to fine tune the amount of apron needed, so as not to design an apron that won't be used. The apron color should be easily distinguishable from the circulating roadway and pedestrian facilities. Work with the region Landscape Architect (HQ Roadside and Site Development Section for regions without a Landscape Architect) for concrete color and texture.

**1320.05(2)(c) Central Island**

The central island is the portion of the roundabout that is inside of the circulating roadway and typically includes an inside truck apron and a landscaped area. Central island shape is a function of the site-specific needs of a roundabout intersection. It doesn't have to be an identical shape of inscribed circle diameter (ICD) dimensions, but should support the design principles of deflection and low speeds, and the accommodation of the design vehicle.

Roundabouts present opportunities to create community focal points, landscaping, and other gateway features within an intersection form that is also safe and efficient. The central island may include enhancements (such as landscaping, sculptures, or fountains), which serve both an aesthetic purpose and provide conspicuity of the intersection for approaching motorists. These treatments should not attract pedestrians to the central island, as they should never cross the circulating roadway.

**1320.05(2)(d) Splitter Island****1. Channelization**

Raised channelization, or the appearance of raised curbing, is important, as research shows that drivers will slow down when they perceive that the driving width is narrowing. This is accomplished for a set distance based on approach speeds. The distance will vary based on the site-specific operational speeds and terrain and the desired entry speed, which is usually 20–25 mph. (See [1320.05\(3\)\(a\)](#) for using chicanes on higher-speed roadways.)

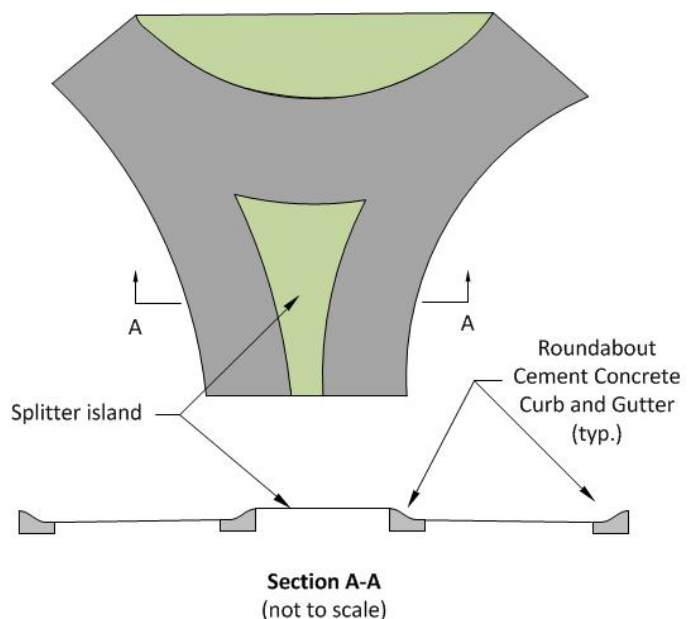

**1320.05(2)(e) Inscribed Circle Diameter (ICD)**

The overall outside diameter of a roundabout is determined by two variables (design vehicle and design speed) and the number of circulatory lanes.

The ranges of ICD in [Exhibit 1320-1](#) are only suggestions to start a roundabout design. The ICD for noncircular shapes should be defined with dimensions along the X and Y axis.

Design Element	Mini <sup>[1]</sup>	Single-Lane	Multilane
Number of Lanes	1	1	2+
Inscribed Circle Diameter <sup>[2]</sup>	45'–80'	80'–150' <sup>[3]</sup>	135'
Circulating Roadway Width	N/A	14'–19'	29'
Entry Widths	N/A	16'–18'	25'
<b>Notes:</b>			
[1] Reserved for urban/suburban intersections with a 25 mph or less posted speed.			
[2] The given diameters assume a circular roundabout; adjust accordingly for other shapes.			
[3] Inscribed circle diameters of less than 100 feet may not be appropriate on a state route.			

**Suggested Initial Design Ranges***Exhibit 1320-1***1320.05(2)(f) Entry****1. Deflection**

Ideal alignment offers an entry design that provides deflection, speed control, and reasonable view angles to drivers while balancing property impacts and costs. While most intersections are at 90° angles and most through movements are straight, deflection contributes to the safety performance of a roundabout. Deflection is primarily achieved by placing a central island and supporting it with splitter islands on both the entries to the roundabout.

**2. Alignment Offset**

There are three choices for attaching entry legs to the circulatory roadway:

- The offset left alignment constrains the entry, slowing vehicles, and opens up the exit for efficient egress.
- The offset right alignment tends to allow faster entry and constrains the exit.
- The symmetrical alignment (if needed) is acceptable for slower speeds.

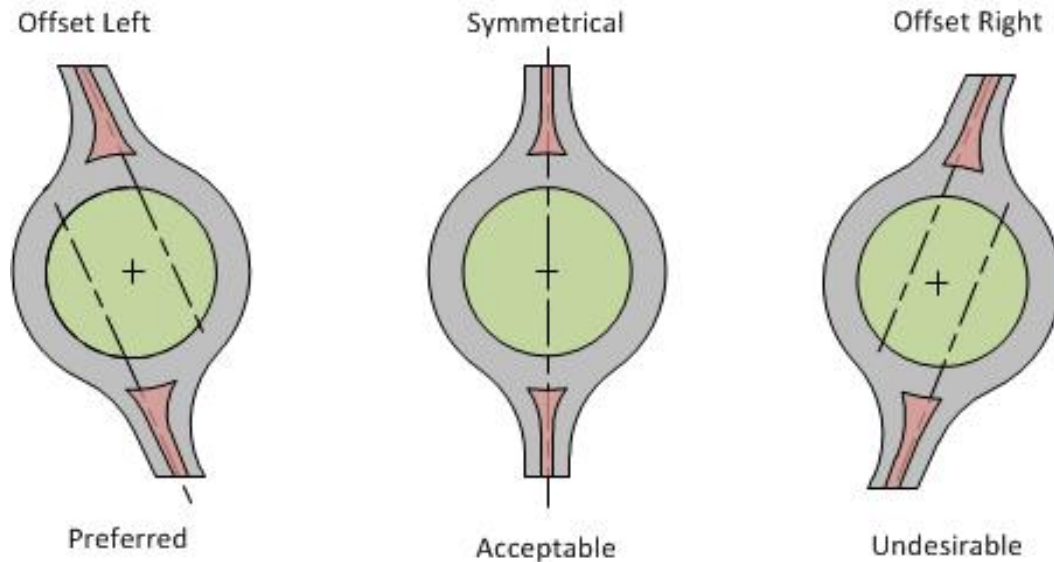

### 3. Entry Angle

To achieve the proper amount of deflection for each approach to a roundabout, there is a range of angle values that are acceptable. This range is usually between 20 and 40 degrees.

### 4. Entry Width

Entry width is determined by the turning template of the design vehicle turning through the entry curve of the needed design speed. The ranges of entry widths in [Exhibit 1320-1](#) are only suggestions to start a roundabout design.

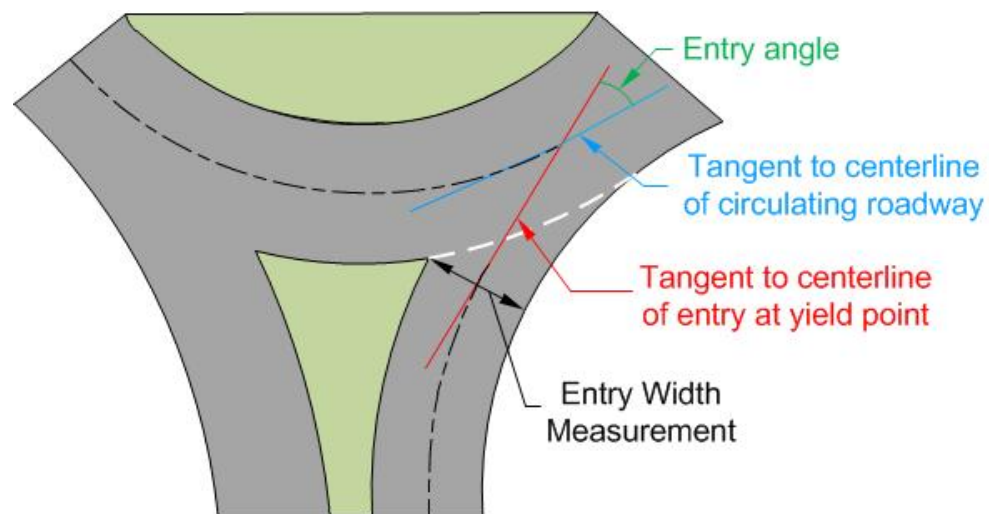

### 5. Path Overlap

If the vehicles in the entry are aligned toward the central island or the truck apron, the vehicle on the right is pointed toward the inside lane and tends to go in that direction, while the vehicle on the left tends to be squeezed to the right toward the vehicle on the right. Avoid path overlap.

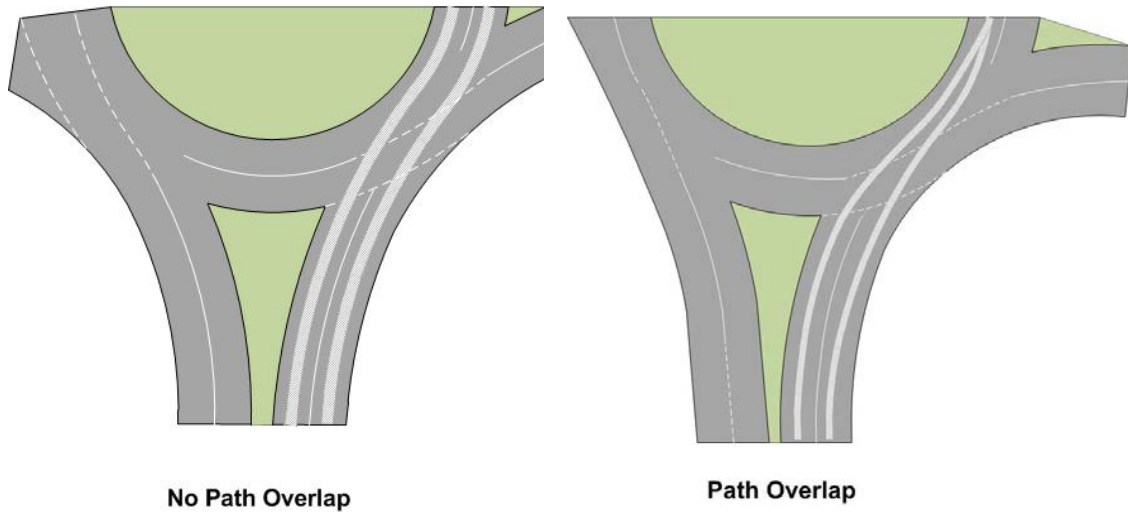

**1320.05(2)(g) Right-Turn Slip Lanes**

Right-turn slip lanes are a proven way to increase the “life” of an intersection by removing traffic that would otherwise enter the roundabout and lower the available capacity to other movements. If a right-turn movement has a total of 250 vehicles/hour, or if over 40% of the total approach volume is taking right turns, slip lanes should be considered.

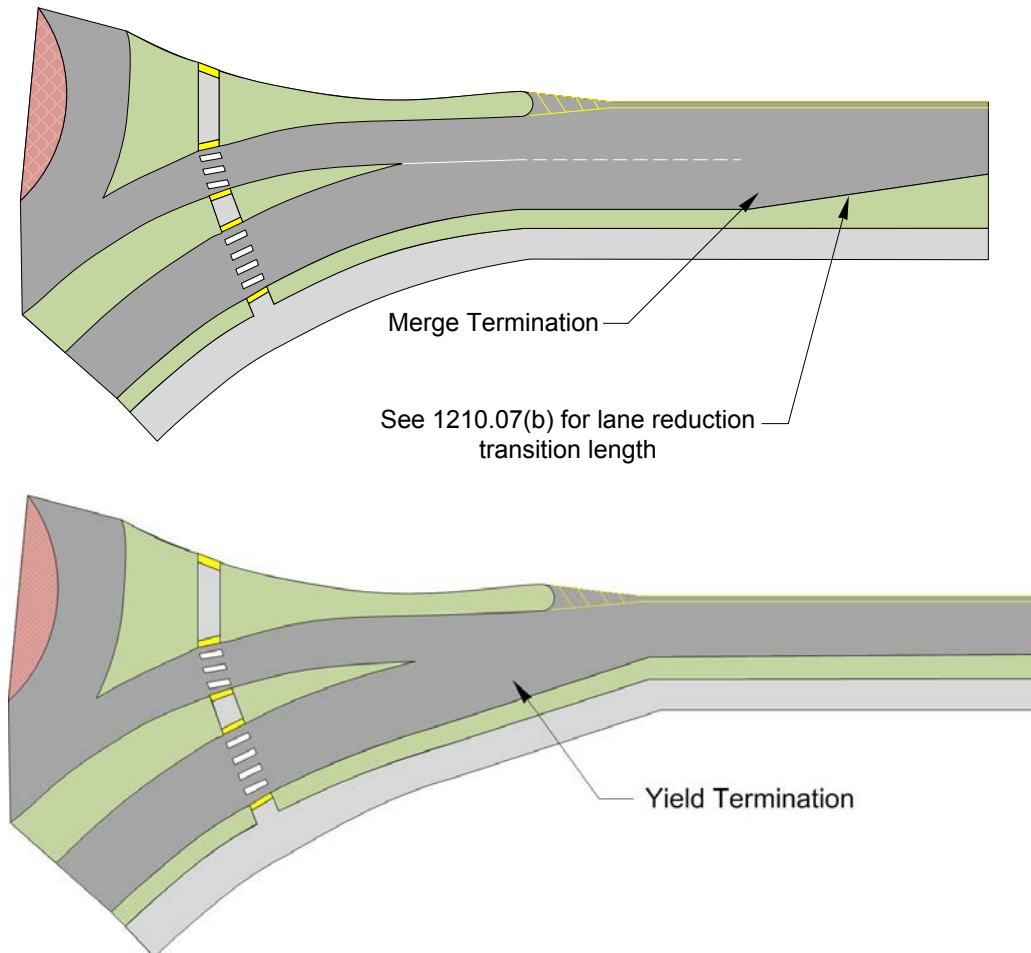

### 1320.05(3) Speed Control

Roundabout operation performance is dependent on low, consistent speeds. Low and consistent operating speeds facilitate driver gap acceptance. Design for travel path operating speeds between 15 mph and 25 mph (see [1320.05\(6\)\(c\)](#)). Design to have low-speed differentials between entering and circulating traffic.

The optimal design speed mechanism is when the design speeds of the entry legs, based on their deflection alignment, are the same or slightly slower than the design speed of the circulation lane(s), so that the vehicle enters the roundabout at that slower speed.

The vehicle then moves into and through the circulation lane, being controlled all along by the design speed of the circulating lane. The circulating design speed controls the exit speed; therefore, the exit design speed is not as critical

Designing this type of speed mechanism encourages lower speeds and lower-speed differentials at conflict points, which reduces the potential for collisions.

#### 1320.05(3)a Chicanes

Chicanes are a type of horizontal deflection used in traffic calming to reduce the speed of vehicles. Research has shown that chicanes have value in slowing down higher approach speeds. **Note:** Use of this component should be documented as a design decision in the DDP.

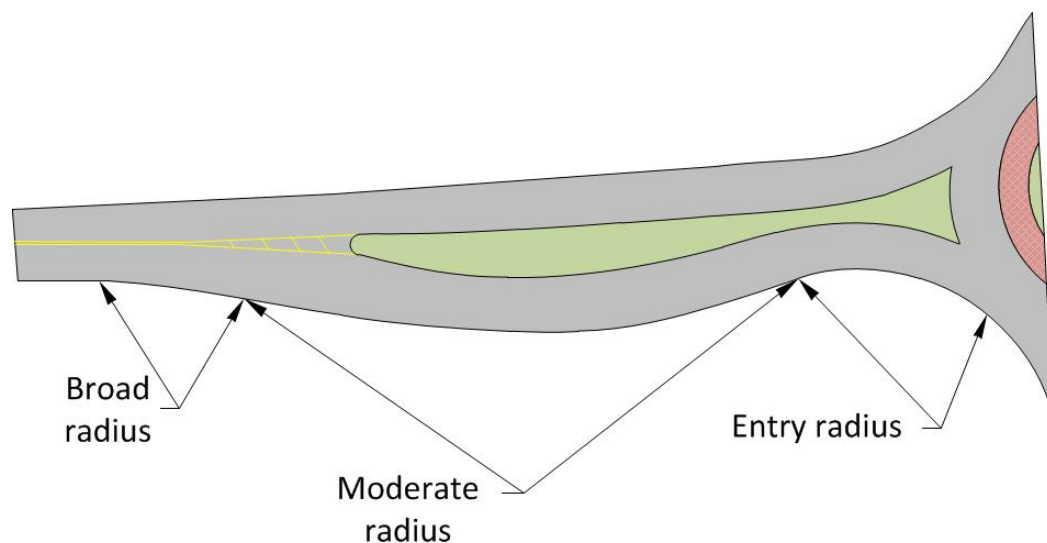

Consider chicanes at approaches of 45 mph or higher. Design chicane curves with successively smaller radii in order to reduce the design speed approaching the roundabout entry; use [Exhibit 1320-2](#) to determine the radii-speed relationship (the radii are measured from the midpoint of the travel lane for single-lane roundabouts). For multilane roundabouts, the radii measurement is from the center of the total pavement width of the entry travel lanes.

All three curves of a chicane are designed to, one by one, successively reduce vehicle speed from the speed of the main line to the speed of the entry curve.

Also, consider the grade of the roadways that enter the roundabout, because a vehicle can more easily slow down on an upgrade than on a downgrade. Adjust the length of the deceleration based on the “Adjustment Factors for Grades Greater Than 3%” in *Design Manual Exhibit 1360-10*.

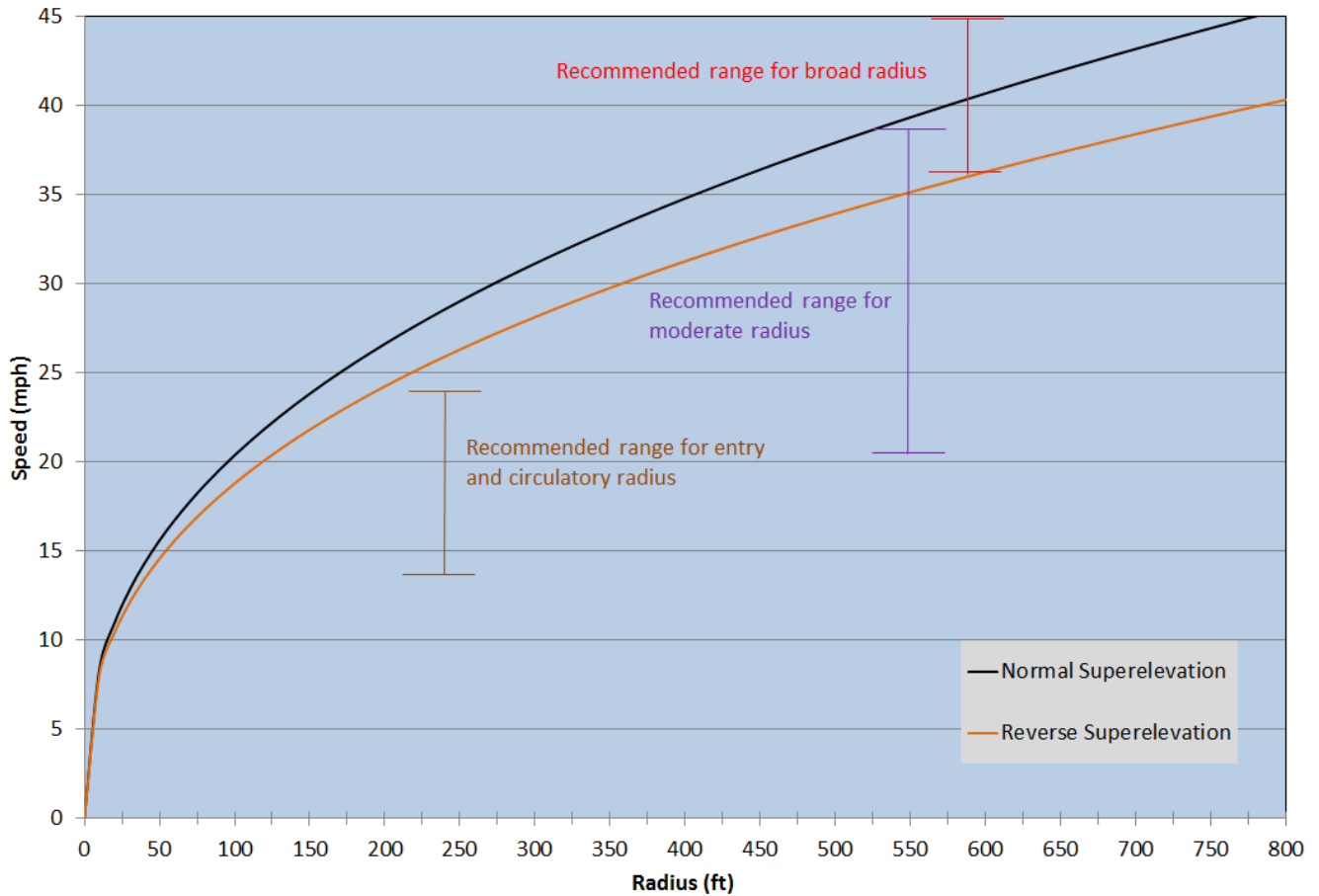

**Radii-Speed Relationship**  
Exhibit 1320-2

**1320.05(4) Grades**

Do not use grades as a constraint during scoping to rule on a roundabout, because typical 90° and other specific-angle intersections work with grade ranges, so there are no limitations to grades at a roundabout. Be aware however of how the profiles mesh with sight distances and ADA pedestrian requirements.

**1320.05(4)(a) Circulatory Roadway**

The circulatory roadway grade value should not exceed 4%.

**1320.05(4)(b) Grade Transitions for Roadway Entry and Exit to the Circulatory Roadway**

Consider the grade transitions and make them as long as feasible.

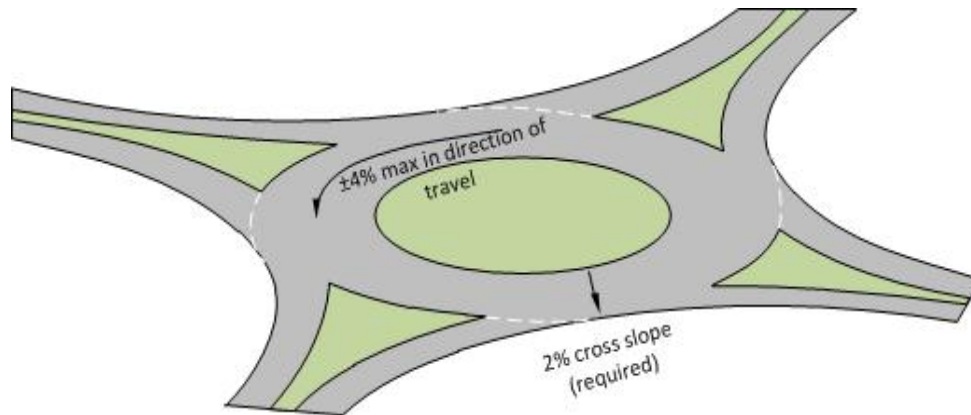

### 1320.05(5) Cross Section Circulatory Roadway

Designers should use a cross slope of 2% away from the central island to promote lower circulating speeds, improve central island visibility, minimize breaks in cross slope of entry and exit lanes, and facilitate drainage of water to the outside of the roundabout.

### 1320.05(6) Design Tools

During scoping, do not use truck turning paths alone as a constraint to rule out a roundabout. There are several design tools available to aid in the design of a roundabout. It is important to understand how the software works and impacts designs, default settings, and so on.

#### 1320.05(6)(a) The Importance of Design Vehicle Assumptions and Wheel Base (WB) Measurements

While all highway-to-highway movements require accommodating a WB-67, there are certain assumptions that must be made with software programs that replicate truck swept paths. Designers should discuss defaults and recognize that on some highway segments, truck percentages are 20%, and on others, they are 2%. Designers should also recognize that among that percentage, WB-67s may only represent a small sample of the entire truck volume on any given day.

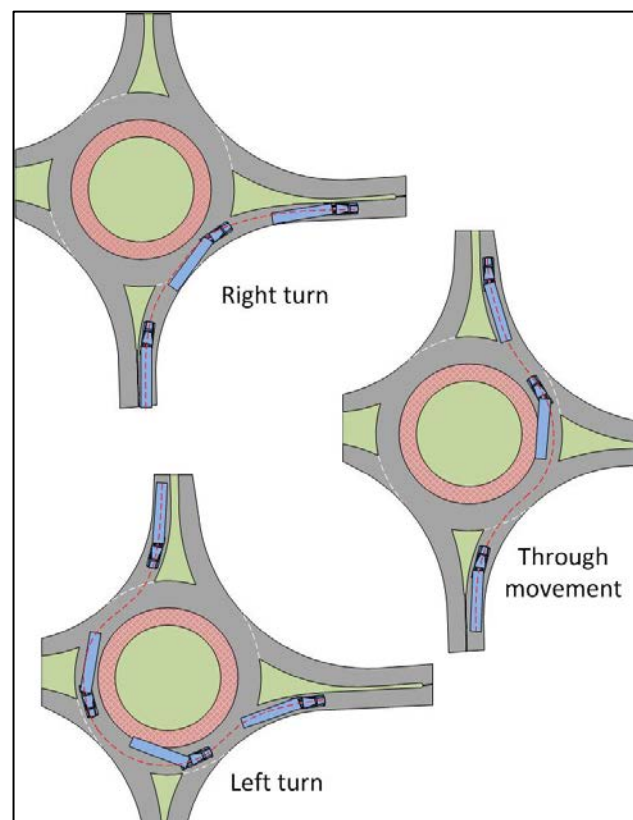

**1320.05(6)(b) Truck Swept Path**

In some cases, roundabouts of the perfect circular variety with symmetrical roadway attachments require less specific knowledge of truck-turning software and its applications. This knowledge curve, however, climbs quickly when looking at shaped roundabouts where a combination of the speed of the truck, its turning angle settings, its rear axle locations, and set up requires a mastery of this software.

Design to slow the speed of the truck, and make good engineering judgment about how fast a truck might use a roundabout (for example, for AutoTURN<sup>®</sup> use 5 mph). Design tool default settings don't necessarily allow the maximization of the tool and can prohibit the designer in getting a good, balanced design between passenger car speeds and truck accommodation.

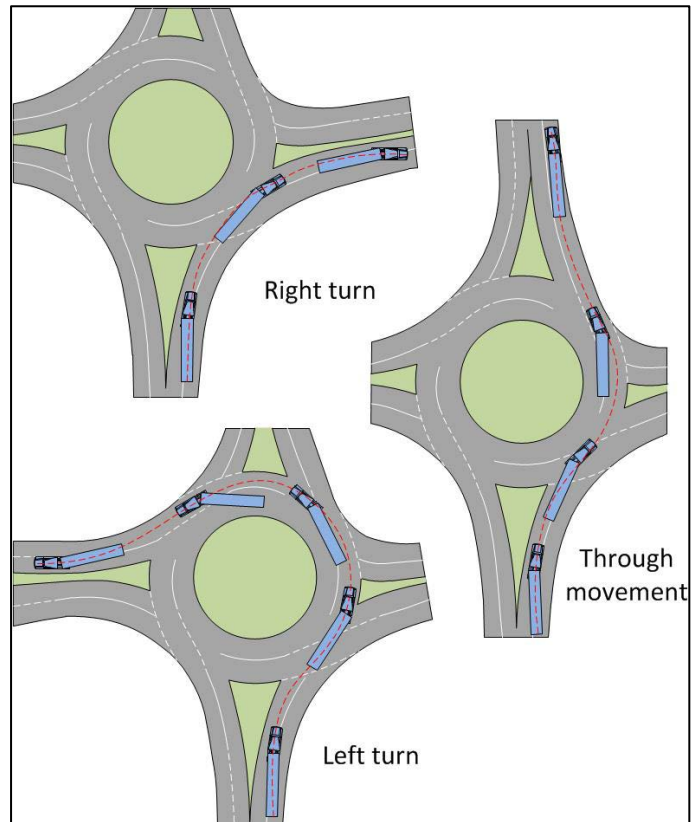

Multilane roundabouts assume truck straddling behavior, so printing out numerous copies of the same path throughout isn't necessarily using the tool. It is okay to say the tool doesn't apply except to specific movements; for example, gas station tankers using a driveway, or a super load that needs to make a specific movement with a wind blade or generator.



**1320.05(6)(c) Travel Paths**

Travel path calculations can be used on multilane designs to get an understanding of speeds for different paths throughout the roundabout. A travel path is the shortest path through the roundabout, no closer than 5 feet from any curb face or lane line (see section 1320.05(3) for speed control).

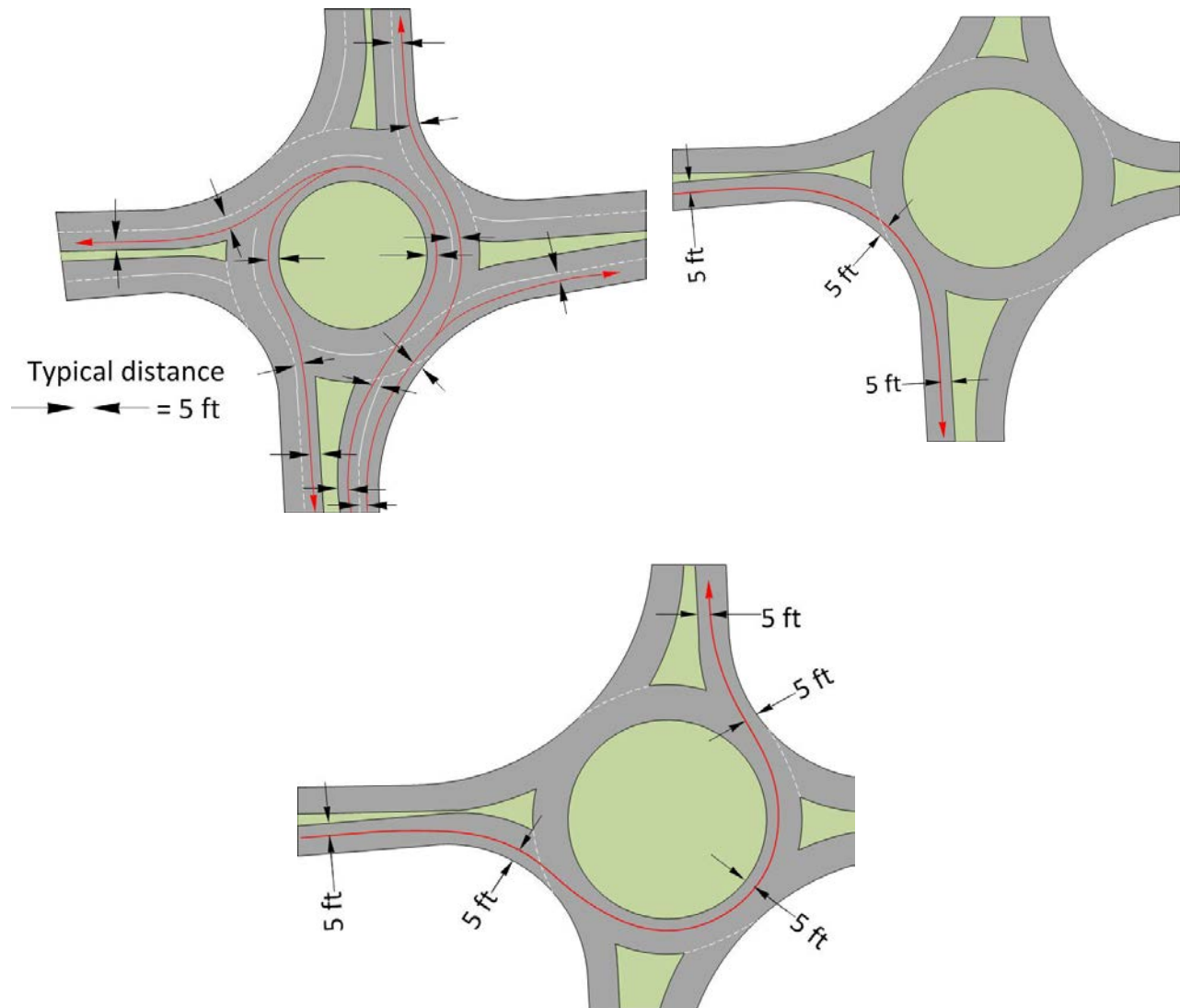
**1320.05(7) Sight Distance**

Sight distance is an important consideration at roundabouts. Restricting sight distance across the central island with strategic landscaping may enhance the intersection by making the intersection a focal point and encouraging lower speeds. Work with the region Traffic Engineer and Landscape Architect (HQ if there is no region contact) to determine this balance. Provide sight triangle plan sheets for consideration of landscape design.

1320.05(7)(a) Stopping

Use the design stopping sight distance guidance in [Chapter 1260](#). Anticipated speeds throughout the roundabout can be calculated using [Exhibit 1320-2](#), based on the radius and direction of the particular curve. These distances are assumed to follow the curvature of the roadway, thus are not measured as straight lines but as distances along the vehicular path.

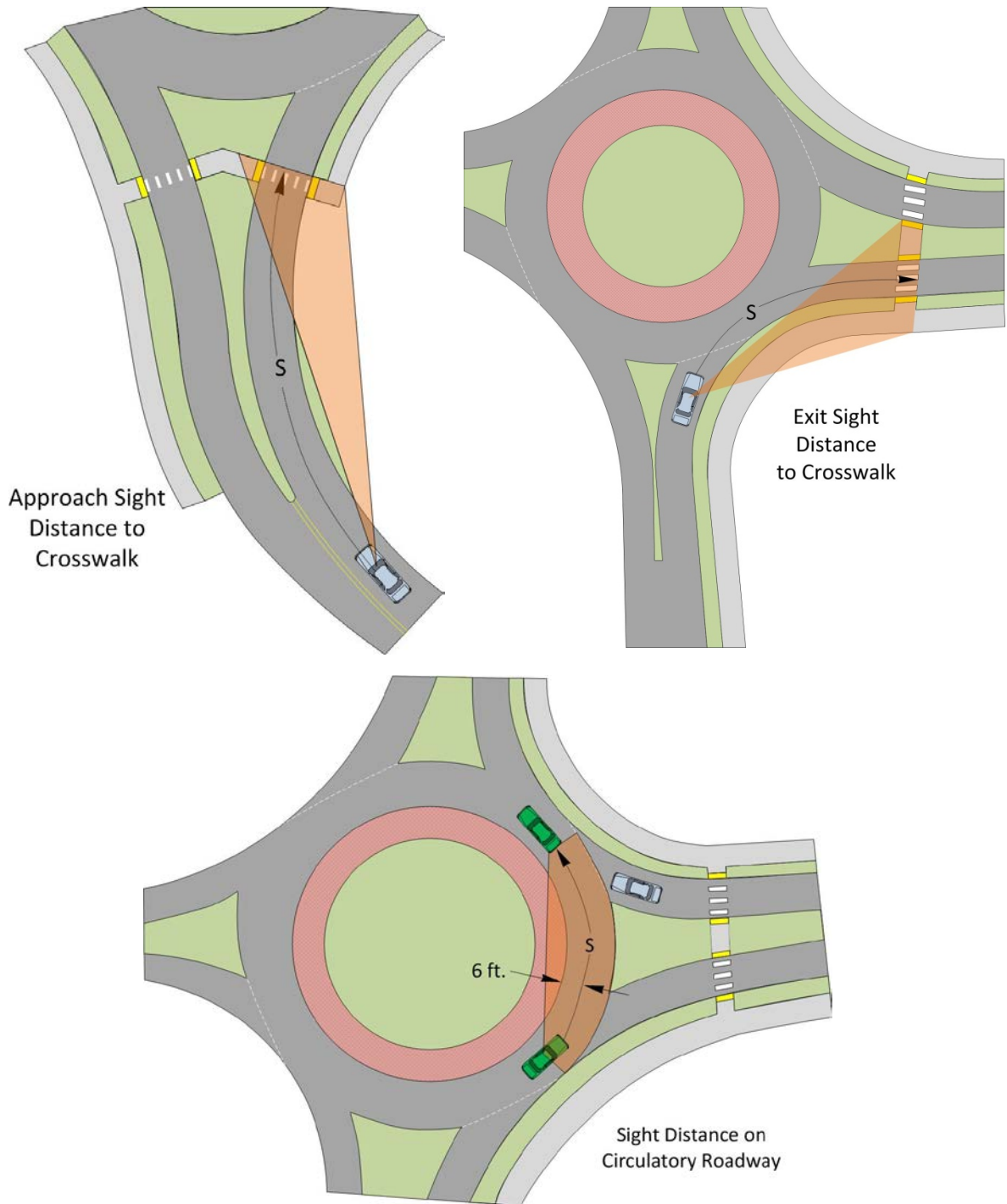

**1320.05(7)(b) Intersection**

There is an advantage to providing minimum intersection sight distance. Longer sight distances can lead to higher vehicle speeds that reduce the safety for all road users. For intersection sight distance at roundabouts, provide entering vehicles a clear view of traffic on the circulating roadway and on the immediate upstream approach in order to judge an acceptable gap. The intersection sight distance at roundabouts is given in Exhibit 1320-3. The  $S_1$  intersection sight distance is based on the average of the entering and circulating speeds, and the  $S_2$  intersection sight distance is based on the left-turning speed. The sight distance may also be calculated using the intersection sight distance equation given in Chapter 1310 using a time gap (tg) of 4.5 seconds.

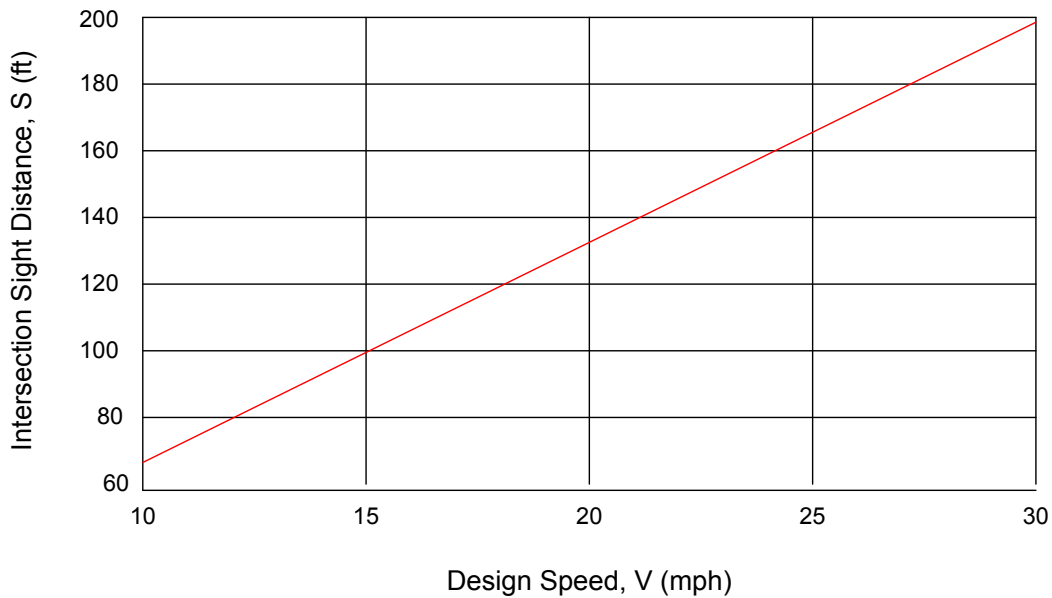

**Intersection Sight Distance**  
Exhibit 1320-3

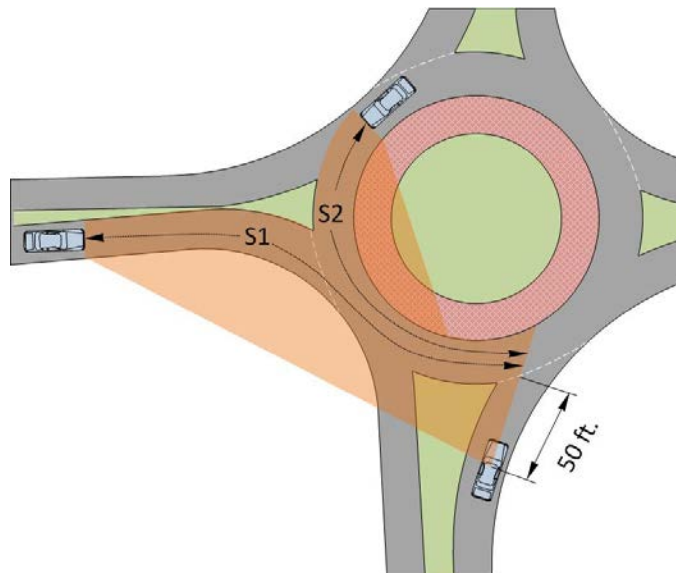

### 1320.05(8) Railroad Crossings

Although it is undesirable to locate intersections near an at-grade railroad crossing, a crossing is acceptable near a roundabout as long as the crossing design does not force vehicles to stop on the tracks. The distance between the yield point and the tracks is sized to at least accommodate the design vehicle length, unless there is a gate on the circulating roadway that allows the roundabout entry to clear prior to the train's arrival.

Intersection analyses and site-specific conditions help determine the need for, and optimum placement of, a gate on the circulating roadway. Two example locations for railroad gates on the circulating roadway are shown; however, only one would be used. While a roundabout has a tendency to lock up as soon as the gates come down on the circulating roadway, the leg with the train is very efficient at returning to normal operation.

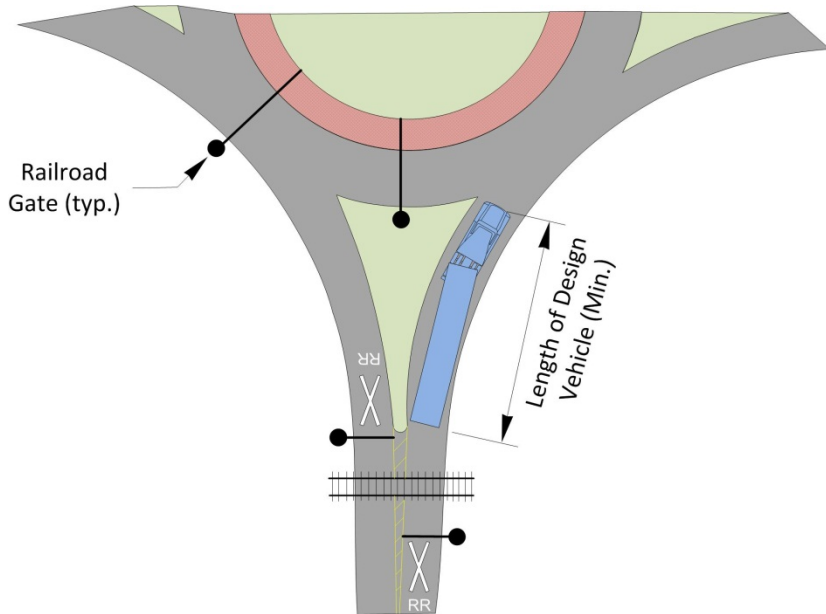

### 1320.06 Pedestrians

As part of the approved Intersection Control Analysis (ICA), it has already been determined whether pedestrians will use the roundabout and, if so, which legs (see [Chapter 1300](#)).

With the knowledge of where pedestrian facilities are needed, design the roundabout while keeping in mind the ADA requirements for crossings, sidewalks, paths, and other pedestrian facilities.

Wherever feasible, sidewalks at roundabouts should be set back from the edge of the circulatory roadway by a buffer. The buffer discourages pedestrians from crossing to the central island or cutting across the circulatory roadway of the roundabout, and it helps guide pedestrians with vision impairments to the designated crosswalks. A buffer between the sidewalk and curb is recommended. Consider a buffer wide enough for low shrubs or grass in the area between the sidewalk and curb to maintain sight distance needs.

#### 1320.06(1) Crossing Location

The crossing located on the entry side of a roundabout leg should be at least 20 feet from the yield line so that a pedestrian can walk behind a vehicle that is waiting at the yield line. If there is an extremely large truck percentage, consider moving the crossing to accommodate the most common truck.

The crossing located in the exit side of the roundabout leg can be closer to the roundabout, because as the vehicles leave the roundabout, they accelerate and make it harder to find a break in traffic. As speed increases, drivers are less likely and less able to stop.

### 1320.06(2) Splitter Island Pass Through

Design splitter island pass through widths 10 feet, or the width of the sidewalk if the sidewalk is greater than 10 feet wide. Design the length (measured back of curb to back of curb) at least 6 feet long measured along the shortest section of the pedestrian path. Consider a “V” shape pass through as shown.

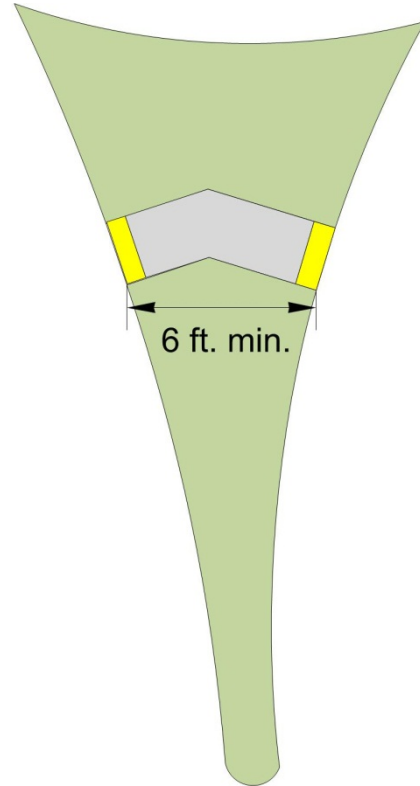

### 1320.06(3) Buffers

It is preferable to have buffers between the sidewalk and the circulatory roadway.

Buffers allow room for curb ramp transition sections and, depending on the width, room for curb ramps out of the pedestrian access route.

### 1320.06(4) Curb Ramps

Roundabouts with buffers typically have combination-type curb ramps; otherwise, parallel curb ramps are normally used. (See [Chapter 1510](#) and the *Standard Plans* for curb ramp information.)

### 1320.06(5) Sight Triangles

Vehicle sight triangles specific to pedestrians (see [1320.05\(7\)](#)) need to be able to see the whole curb ramp, including the landing, where pedestrians are likely to wait to cross.

It is also important that pedestrians are also able to see approaching vehicles.

### 1320.06(6) Pedestrian Beacons

On multilane roundabouts, consider installing pedestrian beacons to warn vehicles that a pedestrian wants to cross the roadway. Work with the region Traffic Engineer on types and locations of pedestrian beacons.

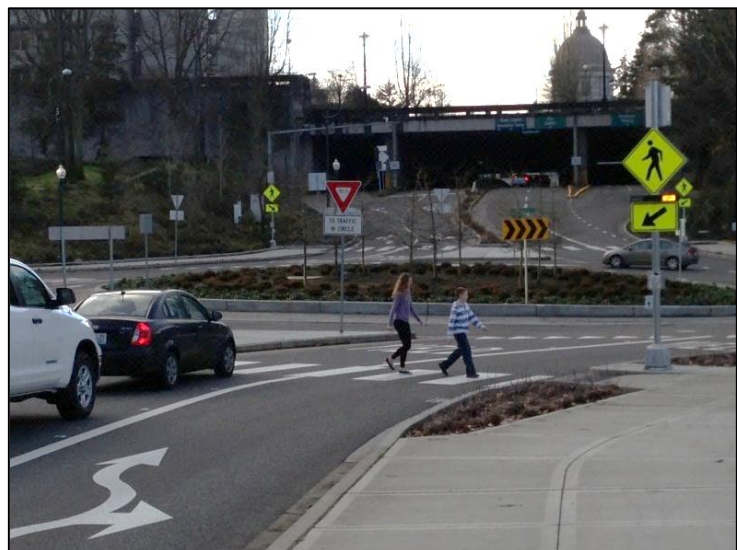

### 1320.07 Bicycles

Bicyclists may be provided similar options to negotiate roundabouts as they have at conventional intersections, where they navigate either as motor vehicles or pedestrians depending on the size of the intersection, traffic volumes, their experience level, and other factors. Bicyclists are often comfortable riding through single-lane roundabouts in low-volume environments in the travel lane with motor vehicles, as speeds are comparable and potential conflicts are low. At larger or busier roundabouts, cyclists may be more comfortable using ramps connecting to a sidewalk around the perimeter of the roundabout as a pedestrian. Where bicycle lanes or shoulders are used on approach roadways, they should end before the geometry changes the approach to the roundabout.



Contact the HQ Design Office for bicycle ramp design options.

### 1320.08 Signing and Pavement Marking

The graphic shown is an example of potential signing for a single-lane roundabout. For additional information, refer to the [MUTCD, Plan Sheet Library](#), and the [Standard Plans](#) for details on signing and pavement marking.

A preliminary sign plan is developed to identify existing and proposed signing on state highways. Sign plans on state routes are to be reviewed and approved by the region Traffic Engineer and then furnished to the HQ Traffic Office for review and concurrence. This plan is to be included as part of the Roundabout Geometric Design (see [1320.11\(2\)](#)).

The plan provides an easily understood graphic representation of the signing, and it provides statewide uniformity and consistency for regulatory, warning, and guide signs at roundabouts on the state highway system. For roundabouts located near a port, industrial area, or route that accommodates oversize loads, consider using perforated square steel posts.



### 1320.09 Illumination

Provide illumination for each of the conflict points between circulating and entering traffic in the roundabout and at the beginning of the raised splitter islands. Illuminate raised channelization or curbing. Position the luminaires on the upstream side of each crosswalk to improve the visibility of pedestrians. Light the roundabout from the outside in toward the center. This improves the visibility of the central island and circulating vehicles to motorists approaching the roundabout. Ground-level lighting within the central island that shines upward toward objects in the central island can also improve their visibility. (See [Chapter 1040](#) for additional information on illumination.) On higher-speed approaches, you may consider internally illuminated bollards (IIB) in lieu of other illumination.

### 1320.10 Road Approach, Parking, and Transit Facilities

No road approach (road or driveway) connections to the circulating roadway are allowed at roundabouts unless they are designed as legs to the roundabout. It is desirable that road approaches not be located on the approach or departure legs within the length of the splitter island. The minimum distance from the circulating roadway to a road approach is controlled by corner clearance using the outside edge of the circulating roadway as the crossroad (see [Chapter 540](#)). If minimum corner clearance cannot be met, provide justification. For additional information on limited access highways, see [Chapter 530](#).

If the parcel adjoins two legs of the roundabout, it is acceptable to provide a right-in/right-out driveway within the length of the splitter islands on both legs. This provides for all movements; design both driveways to accommodate their design vehicles.

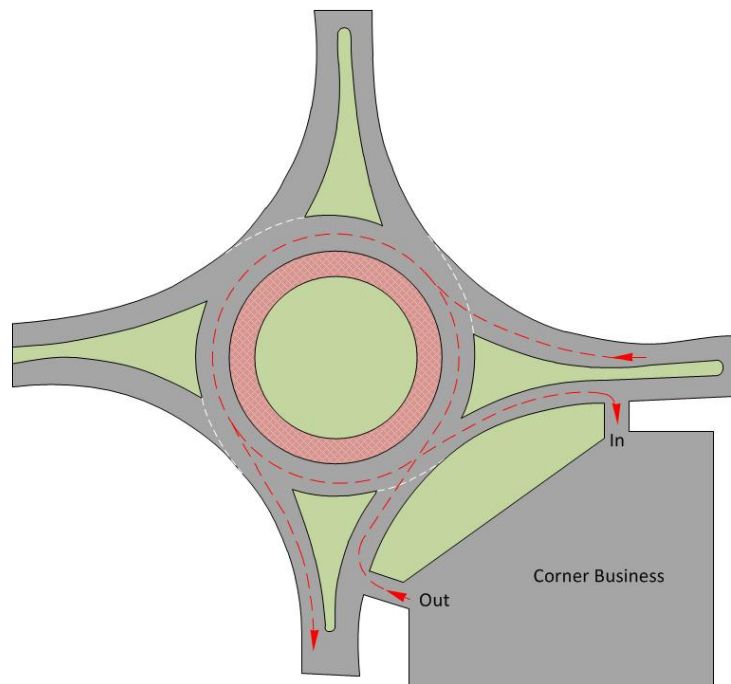

Roadways between roundabouts may have restrictive medians with left-turn access provided with U-turns at the roundabouts.

Parking is not allowed in the circulating roadway or on the entry or exit roadway within the length of the splitter island.

Transit stops are not allowed in the circulating roadway, in the approach lanes, or in the exit lanes prior to the crosswalk. Locate transit stops on the roadway before or after the roundabout, in a pullout, or where the pavement is wide enough that a stopped bus does not block the through movement of traffic or impede sight distance.

## 1320.11 Approvals

### 1320.11(1) Preliminary Geometric Design

Coordination between the design team, region Traffic and Project Development offices, and HQ Traffic and Design offices is essential for a roundabout design layout.

Conduct an early meeting with the region Traffic Office, the region Project Development Engineer or Engineering Manager, and the HQ Traffic and Design offices. The intent of this meeting is to review, discuss, and evaluate initial layouts for a roundabout before too much time and resources have been expended. The outcome of the meeting will provide sufficient information that a designer can proceed with finalizing the geometric design.

As a minimum, consider, discuss, and document the following items for the meeting.

#### 1320.11(1)(a) Project Overview

##### 1. Summary of the Approved Intersection Control Analysis (ICA)

Some items to include:

- Preliminary layout
- Design vehicle
- Sight distances
- Vehicle turn simulation software (such as AutoTURN<sup>®</sup>)

##### 2. Other Topics for Discussion

Additional items to discuss and consider in the design of the roundabout may include:

- Travel path speeds
- Splitter island design: Provide a smooth entry alignment into the roundabout
- Other roundabout shapes
- Bike and pedestrian design, including ADA requirements and rapid flash beacons
- Central island design
- Curbing details
- Signing, illumination, and delineation considerations
- Staging and traffic control during construction
- Vertical grade
- Adjacent posted speeds
- Existing and future corridor congestion





The iterative nature of roundabout design requires a high level of communication in determining design details, construction sequencing, and so on. Additional meetings are recommended as necessary to review and discuss the progress of the design. A peer review may also be beneficial on more complex designs.

### **1320.11(2) Final Geometric Design**

The Roundabout Geometric Design Package is the documentation of the final roundabout design and decisions. This package should be approved prior to PS&E work.

As a minimum, include the following items in the Roundabout Geometric Design Package:

- (a) Intersection Control Analysis (ICA).
- (b) Intersection plan showing the roundabout channelization.
- (c) Summary of the design documentation that pertains to the roundabout.
- (d) Roundabout geometric data, including the following:
  - Provide detailed drawings showing the travel paths and speeds for each movement.
  - Provide a table summarizing stopping and intersection sight distance on each leg.
  - Provide turn paths showing design vehicle, WB-67, and largest oversize vehicle movements using turn simulation software (such as AutoTURN<sup>®</sup>).
- (e) Detailed drawings of the splitter islands on each leg.
- (f) Preliminary signing, delineation, and illumination plans.
- (g) Curb types used.
- (h) Central island/Landscape design.
- (i) Bike and pedestrian design, including ADA requirements.

A roundabout review checklist and example package is located on the Project Development web page: [www.wsdot.wa.gov/design/projectdev](http://www.wsdot.wa.gov/design/projectdev)

### **1320.12 Documentation**

Refer to [Chapter 300](#) for design documentation requirements.



- 1330.01 General
- 1330.02 References
- 1330.03 Definitions
- 1330.04 Procedures
- 1330.05 Signal Warrants
- 1330.06 Conventional Traffic Signal Design
- 1330.07 Documentation

### 1330.01 General

Traffic control signals are power-operated traffic control devices that warn or direct motorists to take a specific action. They are used to control the assignment of right of way at locations where conflicts with motorists, bicyclists, and pedestrians exist or where passive devices such as signs and markings do not provide the necessary flexibility of control to move motorists, bicyclists, and pedestrians in an efficient manner.

The decision to install a traffic signal is the result of an Intersection Control Analysis (ICA) that is approved by the region Traffic Engineer or other designated authority.

### 1330.02 References

The following references are used in the planning, design, construction, and operation of traffic control signals installed on state highways. The RCWs noted are specific state laws concerning traffic control signals, and conformance to these statutes is required.

#### (1) Federal/State Laws and Codes

Americans with Disabilities Act of 1990 (ADA) (23 CFR Part 36, Appendix A)

[Revised Code of Washington \(RCW\) 35.77](#), Streets – Planning, establishment, construction, and maintenance

[RCW 46.04.450](#), Railroad sign or signal

[RCW 46.04.600](#), Traffic control signal

[RCW 46.04.62250](#), Signal preemption device

[RCW 46.61.050](#), Obedience to and required traffic control devices

[RCW 46.61.055](#), Traffic control signal legend

[RCW 46.61.060](#), Pedestrian control signals

[RCW 46.61.065](#), Flashing signals

[RCW 46.61.070](#), Lane-direction-control signals

[RCW 46.61.072](#), Special traffic control signals – Legend

[RCW 46.61.075](#), Display of unauthorized signs, signals, or markings

[RCW 46.61.080](#), Interference with official traffic-control devices or railroad signs or signals

[RCW 46.61.085](#), Traffic control signals or devices upon city streets forming part of state highways – Approval by department of transportation

[RCW 46.61.340](#), Approaching train signal

[RCW 47.24.020\(6\)](#) and [\(13\)](#), Jurisdiction, control

[RCW 47.36.020](#), Traffic control signals

[RCW 47.36.060](#), Traffic devices on county roads and city streets

[Washington Administrative Code \(WAC\) 468-18-040](#), Design standards for rearranged county roads, frontage roads, access roads, intersections, ramps and crossings

[WAC 468-18-050](#), Policy on the construction, improvement and maintenance of intersections of state highways and city streets

“City Streets as Part of State Highways: Guidelines Reached by the Washington State Department of Transportation and the Association of Washington Cities on the Interpretation of Selected Topics of [RCW 47.24](#) and Figures of [WAC 468-18-050](#) for the Construction, Operations and Maintenance Responsibilities of WSDOT and Cities for Such Streets,” April 30, 1997.

## **(2) Design Guidance**

*A Policy on the Geometric Design of Highways and City Streets* (Green Book), AASHTO, 2004

[Directive D 55-03](#), “Responsibility for Traffic Control Devices, Pavement Widening, and Channelization at Existing Intersections and Two-Way Left Turn Lanes in Cities”

*Guide for Determining Time Requirements for Traffic Signal Preemption at Highway-Rail Grade Crossings*, MNDOT, 2006

*Manual on Uniform Traffic Control Devices for Streets and Highways*, USDOT, FHWA; as adopted and modified by Chapter [468-95 WAC](#) “Manual on uniform traffic control devices for streets and highways” (MUTCD)

*Plans Preparation Manual*, M 22-31, WSDOT

*Revised Draft Guidelines for Accessible Public Rights of Way*, U.S. Access Board, Nov. 2005

*Standard Plans for Road, Bridge, and Municipal Construction (Standard Plans)*, M 21-01, WSDOT

*Standard Specifications for Road, Bridge, and Municipal Construction (Standard Specifications)*, M 41-10, WSDOT

WSDOT Traffic Design Resources

[www.wsdot.wa.gov/Design/Traffic/](http://www.wsdot.wa.gov/Design/Traffic/)

WSDOT is responsible for only the maintenance and operation of a traffic signal. The county is responsible for the construction costs of the traffic signal and associated illumination. When it is necessary to construct a traffic signal at an existing county road and state highway intersection, the construction cost distribution is based on the volume of traffic entering the intersection from each jurisdiction's roadway. The county's share of the cost, however, is limited to a maximum of 50%. The state is responsible for maintenance and operation ([WAC 468-18-040](#)).

- (e) **Outside the corporate limits of cities and inside established limited access control areas:** WSDOT is responsible for funding, construction, maintenance, and operation of traffic signals.
- (f) **Emergency vehicle signals:** The emergency service agency is responsible for all costs associated with emergency vehicle signals.
- (g) **Third party agreement signals:** At those locations where WSDOT is responsible for traffic signals and agrees with the alternatives analysis that the proposed traffic signal is justified, but where funding schedules and priorities do not provide for the timely construction of the traffic signal requested by others, the following rules apply:
  - The third party agrees to design and construct the traffic signal in conformance with WSDOT's guidelines and requirements.
  - The third party agrees to submit the design and construction documents to WSDOT for review and approval by the region Traffic Engineer.
  - The third party obtains a traffic signal permit.
  - Third party agreement(s) with incorporated cities will be part of the DDP.

### 1330.05 Signal Warrants

A signal warrant is a minimum condition that is to be met before a signal may be installed. Satisfying a warrant does not mandate the installation of a traffic signal. The warranting condition indicates that an engineering study, including a comprehensive analysis of other traffic conditions or factors, is needed to determine whether the signal or another improvement is justified. This is the Intersection Control Analysis performed during the scoping of the project (see [Chapter 1300](#)). For a list of the traffic signal warrants and information on how to use them, see the [Manual on Uniform Traffic Control Devices](#) (MUTCD). Include the selected signal warrants in the DDP.

A proposal to install a traffic signal on any state route with a posted speed of 45 mph or higher requires an alternatives analysis, approved by the region Traffic Engineer, with review and comment by the HQ Design Office.

### 1330.06 Conventional Traffic Signal Design

#### (1) General

The goal of any traffic signal design is to assign right of way in the most efficient manner possible and still be consistent with traffic volumes, intersection geometrics, and safety.

## (2) Signal Phasing

With some exceptions, the fewer the traffic signal phases, the more efficient the operation of the traffic signal. The number of phases required for efficient operation is related to intersection geometrics, traffic volumes, composition of traffic flow, turning movement demands, and desired level of driver comfort. The traffic movements at an intersection have been standardized to provide a consistent system for designing traffic signals. (See [Exhibit 1330-2](#) for standard intersection movements, signal head numbering, and standard phase operation, and see [Exhibit 1330-3](#) for phase diagrams for various traffic signal operations.)

### (a) Left-Turn Phasing

Left-turn phasing can either be permissive, protected/permissive, or protected. It is not necessary that the left-turn mode for an approach be the same throughout the day. Varying the left-turn mode on an approach among the permissive only, protected/permissive, and protected-only left-turn modes during different periods of the day is acceptable.

#### 1. Permissive Left-Turn Phasing

Permissive left-turn phasing requires the left-turning vehicle to yield to opposing through traffic and pedestrians. Permissive left-turn phasing is used when the turning volume is minor and adequate gaps occur in the opposing through movement. This phasing is more effective on minor streets where providing separate protected turn phasing might cause significant delays to the higher traffic volume on the main street. On high-speed (posted speed of 45 mph or above) single-lane approaches or where sight distance is limited, the preferred channelization would include a separate left-turn storage lane for the permissive movement to reduce the potential for rear-end-type collisions and delay to through movements.

#### 2. Protected/Permissive Left-Turn Phasing

Protected/permissive left-turn phasing provides the left-turn movements with an exclusive nonconflicting phase followed by a secondary phase when vehicles are required to yield to opposing traffic. The traffic signal can also operate with the permissive left-turn phase first followed by the protected left-turn phase. Where left-turn phasing will be installed and conditions do not warrant protected-only operation, consider protected/permissive left-turn phasing. Protected/permissive left-turn phasing can result in increased efficiency at some types of intersections, particularly “T” intersections, ramp terminal intersections, and intersections of a two-way street with a one-way street where there are no opposing left-turn movements.

Protected/permissive left-turn phasing is not allowed under the following conditions:

- On the approaches of a signal where Warrant 7 is met and there are five left-turning collisions on that approach included in the warranting collisions.
- When documentation shows that existing protected left-turn phasing was installed due to left-turn collisions.

- 1340.01 General
- 1340.02 References
- 1340.03 Design Considerations
- 1340.04 Driveway Design Templates
- 1340.05 Sidewalks
- 1340.06 Driveway Sight Distance (Eye height – 3.5 ft., Object height – 3.5 ft.)
- 1340.07 Stormwater and Drainage
- 1340.08 Mailboxes
- 1340.09 Documentation

## 1340.01 General

For the purpose of this chapter, and to remain consistent with WSDOT’s *Standard Plans* and AASHTO terminology, the terms “access” and “approach” will be referred to as “driveway.” An access on a managed access highway is defined as an “access connection,” while an access on a limited access highway is defined as an “approach.”



This chapter describes the design guidelines, including sight distance criteria, for driveway connections on the state highway system. WSDOT controls driveways on all limited access state highways, and regulates driveways on all managed access state highways outside the incorporated limits of a city or town. [RCW 47.50.030](#) states that cities and towns, regardless of population size, are the permitting authority for managed access state highways within their respective incorporated city and town limits. The RCW also requires those cities and towns to adopt standards for access permitting on managed access state highways that meet or exceed WSDOT standards, provided those adopted standards are consistent with WSDOT standards.

Limited access highways are roadways to which WSDOT has acquired the access rights from abutting property owners. Driveways, if they have been allowed, are documented and recorded in a deed. [Chapter 530](#) describes the three levels of limited access highways: full, partial, and modified. Any change to the number, type, and use of a limited access driveway must be approved by Headquarters through the process outlined in [Chapter 530](#). A general permit is required to allow any new construction or repairs for a deeded driveway on a limited access highway. Access connection permits are not issued on limited access highways.

Any roadway that is not a limited access highway is a managed access highway. [Chapter 540](#) describes the five classes of managed access highways: Class 1 (most restrictive) to Class 5 (least restrictive). An access connection permit is required to allow the use, operation, and maintenance of a driveway connection on a managed access highway, outside incorporated cities, where WSDOT is the access permitting authority. Check with Development Services to ascertain where WSDOT has permitting authority (such as tribal lands or National Parks).

## 1340.02 References

### 1340.02(1) State Laws and Codes

[Revised Code of Washington \(RCW\) 47.32.150](#), Approach roads, other appurtenances – Permit

[RCW 47.32.160](#), Approach roads, other appurtenances – Rules – Construction, maintenance of approach roads

[RCW 47.32.170](#), Approach roads, other appurtenances – Removal of installations from right-of-way for default

[Chapter 47.50 RCW](#), Highway access management

[Chapter 47.52 RCW](#), Limited access facilities

[Chapter 468-51 Washington Administrative Code \(WAC\)](#), Highway access management access permits – Administrative process

[Chapter 468-52 WAC](#), Highway access management – Access control classification system and standards

[Chapter 468-58 WAC](#), Limited access highways

### 1340.02(2) Design Guidance

[Right of Way Manual](#), M 26-01, WSDOT

[Standard Plans for Road, Bridge, and Municipal Construction \(Standard Plans\)](#), M 21-01, WSDOT

[Development Services Manual](#), M 3007, WSDOT

Limited Access and Managed Access Master Plan, WSDOT

[www.wsdot.wa.gov/design/accessandhearings/tracking.htm](http://www.wsdot.wa.gov/design/accessandhearings/tracking.htm)

## 1340.03 Design Considerations

### 1340.03(1) General

The design of a driveway is based on the usage, design vehicle, and traffic volumes anticipated for the driveway. Generally, the driveway should be designed to accommodate the largest vehicle that will regularly use the driveway. For example, a residential driveway connection will typically have smaller radii and a narrower access width than a higher-volume commercial driveway.

However, if the property owner regularly has larger-wheelbase vehicles using the driveway, such as a home-based work vehicle, recreational vehicle, or truck and boat trailer combination, then a larger driveway may be appropriate.



Conversely, some driveways, such as a rural locked and gated utility, farm, or logging access that larger vehicles sometimes use, may be better served with a smaller and narrower access. This is based on infrequent use and to prevent unauthorized use or dumping of debris on or near the driveway. Other design considerations are:

- Prevent stormwater from flowing onto the roadway from the driveway.
- Properly size culverts under the driveway to adequately accommodate the conveyance of stormwater in the roadway ditches and swales.
- Provide driveway sight distance.
- Accommodate for mailbox placement.
- Ensure surfacing materials and depths are appropriate.
- Generally, extend paving to the right of way line depending on the location/purpose of the driveway. The desirable intersection angle of the driveway is 90°, with 60° to 120° allowed.

### **1340.03(2) WSDOT Projects**

When a project's Design Matrix (see [Chapter 1100](#)) includes "access" as a design element, review existing driveways for possible alterations, relocations, consolidations, or closures. The first step in that process is to determine the legality of the driveway. The region Development Services Office can provide a list of the permitted driveway connections on a managed access highway, noting that, per [RCW 47.50.080](#), Permit removal, "Unpermitted connections to the state highway system in existence on July 1, 1990, shall not require the issuance of a permit and may continue to provide access to the state highway system, unless the permitting authority determines that such a connection does not meet minimum acceptable standards of highway safety." As a result, driveway connections on a managed access state highway can be considered to be permitted, grandfathered, or unpermitted as described below:

- *Permitted* driveways hold a valid permit and shall remain valid until modified or revoked.
- *Grandfathered* driveways that were in existence and in active use consistent with the type of connection on July 1, 1990, may continue to provide connection to the state highway system. They do not require the issuance of a new permit and may continue to provide access to the state highway system, unless the permitting authority determines that such a connection does not meet minimum acceptable standards of highway safety.
- *Unpermitted* driveways are not allowed. The permitting authority may initiate action to close the unpermitted driveway in compliance with the applicable chapters of [47.50 RCW](#) and [468-51](#) and [468-52 WAC](#). These are driveways that do not have a permit and were constructed after July 1, 1990.

If a WSDOT project proposes to alter, relocate, consolidate, or close a driveway—regardless of whether the driveway is permitted, grandfathered, or unpermitted—it is required that a new access connection permit be issued for any driveways that are to remain. If a driveway is to be removed, formal notification to the property owner will be provided as specified in [WAC 468-51-040](#). Unless determined otherwise, the affected property owners of driveways that will be altered, relocated, consolidated, or closed will not have the right of an adjudicative proceeding. Additional information regarding this process can be obtained by contacting your region's Development Services Office.

On limited access highways, both the region Development Services and Real Estate Services offices may provide assistance to determine the legality of an existing driveway. Federal Highway Administration approval is required for driveway modifications on Interstate facilities.

### 1340.04 Driveway Design Templates

There are two design templates for use where there is no adjacent sidewalk. (When a driveway connection has or will have adjacent sidewalk, see 1340.05.) The templates may be used on both limited access and managed access state highways. If an Interstate limited access driveway is allowed, it must be gated. Considering the context of use, Exhibit 1340-1 is generally used for design vehicles of SU-30 and smaller, while Exhibit 1340-2 is generally used for design vehicles of SU-30 and larger.

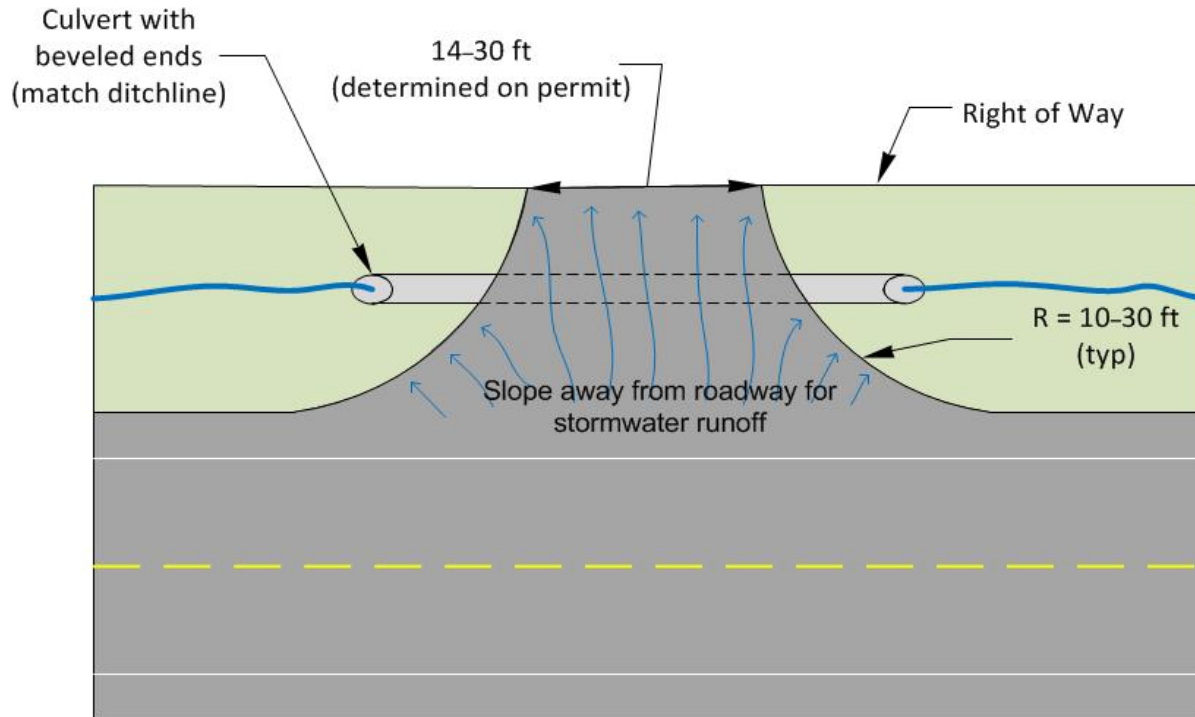

**Driveway Design Template SU-30 and Smaller**  
Exhibit 1340-1

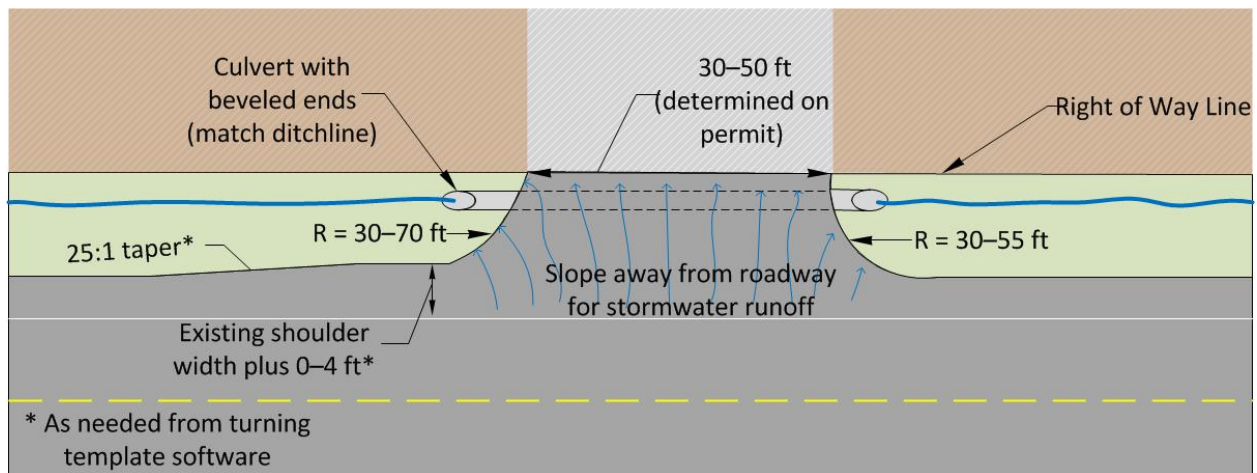

**Driveway Design Template SU-30 and Larger**  
Exhibit 1340-2

Use the design template that will best accommodate the intended use of the driveway, unless a smaller driveway is appropriate and will not adversely affect the traveled way of the state highway. If necessary, use turn simulation software (such as AutoTURN®) to verify the driveway design will adequately accommodate the largest vehicle that will regularly use the driveway.

**1340.05 Sidewalks**

If a driveway connection has (or will have) adjacent sidewalk, use the applicable Cement Concrete Driveway Entrance [Standard Plan F-80.10](#) and width issued on the access permit. The design and construction of any sidewalk shall be compliant with [Chapter 1510](#) and Section F of the [Standard Plans](#), in addition to the latest Americans with Disabilities Act criteria.

**1340.06 Driveway Sight Distance (Eye height – 3.5 ft., Object height – 3.5 ft.)**

A driver on the highway needs to see far enough ahead to assess developing situations and take actions appropriate for the conditions, such as when a vehicle is either entering or leaving the highway at a driveway.

In addition, drivers entering the highway from a driveway also need to see enough of the highway, whether to the left or right, so they can take actions appropriate for the conditions to enter the highway in a reasonably safe manner.

Design and locate driveways such that the sight distances meet or exceed the distances shown in [Exhibit 1340-3](#); these distances may require an approaching vehicle to reduce speed or stop to prevent a collision. In addition, provide decision sight distance for through traffic at all utility and special-use driveways on facilities with limited access control (see [Chapter 1260](#)).

For road approaches with AWDVTE greater than 1,500, use intersection sight distance criteria (see [Chapter 1310](#)). Areas along driveway legs and across their included corners should be clear of obstructions that might block or affect a driver’s view of potentially conflicting vehicles.

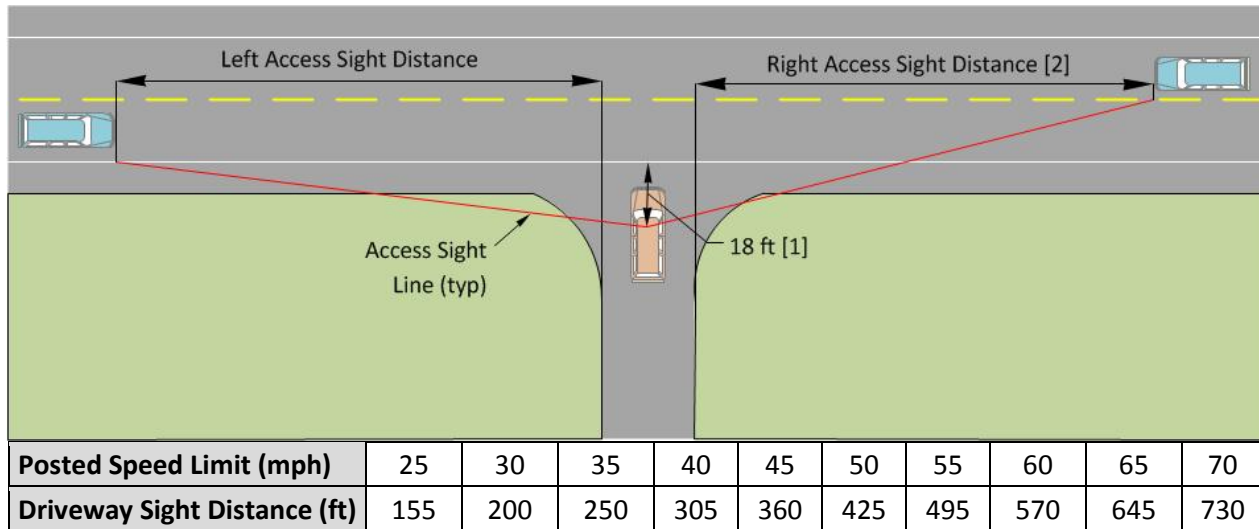

**Notes:**

- [1] Measured from the edge of through lane. If the desirable 18-foot setback cannot be achieved, obtain as much as practicable, down to a 10-foot minimum.
- [2] Not required for driveways restricted to right in/right out.

**Driveway Sight Distance**  
*Exhibit 1340-3*

### 1340.07 Stormwater and Drainage

Design a driveway to slope away from the highway for a distance to prevent stormwater runoff and other debris from flowing onto the traveled lanes and shoulders of the highway. If this is not feasible, then other measures may be necessary to divert the stormwater away from the traveled lanes and shoulder of the highway.

If the driveway will in any way interfere with the flow of stormwater in an existing ditch or swale located on the state highway right of way, install a culvert with beveled ends (see [Chapter 1600](#)). Choose a culvert size that will adequately handle the stormwater (see the *Highway Runoff Manual*). Contact either the region hydraulic engineer or the applicable region maintenance office for assistance. Consider placing quarry spalls at each end of the open culvert to prevent erosion. If the installation of new culvert requires the installation of a catch basin, it is desirable to locate the catch basin outside the normal traveled way of the driveway.



### 1340.08 Mailboxes

Refer to [Chapter 1600](#), Roadside Safety, for guidance regarding the placement of mailboxes.

### 1340.09 Documentation

Refer to [Chapter 300](#) for design documentation requirements.

1350.01	General
1350.02	References
1350.03	Plans
1350.04	Traffic Control Systems
1350.05	Nearby Roadway Intersections
1350.06	Pullout Lanes
1350.07	Crossing Surfaces
1350.08	Crossing Closure
1350.09	Traffic Control During Construction and Maintenance
1350.10	Railroad Grade Crossing Petitions and WUTC Orders
1350.11	Grade Crossing Improvement Projects
1350.12	Light Rail
1350.13	Documentation

### 1350.01 General

Highway-rail grade crossings (“grade crossings”) are the intersection of two modes of transportation with very different physical and operational characteristics. Because of the inherent limitations associated with train operations, [RCW 46.61.350](#) gives train traffic the right of way at grade crossings, thereby assigning motorists the primary responsibility to avoid collisions.

There are many variables that influence a motorist’s ability to react appropriately at grade crossings, including what information is available to them as they approach the crossing and human factors such as competing decisions, distractions, and impaired driving. Primary factors in the design of grade crossings are roadway and railway geometry; available sight distance; highway and railway speeds; competing decisions or visual distractions; and the types of warning devices at the grade crossing.

Another aspect of grade crossing design is coordination of highway traffic signal operations with grade crossing active warning devices (“railroad preemption”) when signalized intersections are located near grade crossings. In such instances, railroad preemption is designed to clear the tracks of any vehicles that may be stopped as a result of the highway traffic signal when a train is approaching the grade crossing. Further guidance on railroad preemption requirements is provided in [Chapter 1330](#).

Grade crossings are also unique due to their multijurisdictional nature. Highway authorities and railroad companies are each legally responsible for different elements at grade crossings. Additionally, the Washington Utilities and Transportation Commission (WUTC) is the state regulatory agency with oversight of public grade crossings in Washington, except within the limits of first class cities in accordance with [RCW 81.53.240](#). Establishing new crossings, altering existing crossings, or closing crossings all require WUTC approval. Therefore, highway projects that include a grade crossing will generally require close coordination with both the railroad company and the WUTC.

Projects that include grade crossings will generally require execution of construction and maintenance agreements between the Washington State Department of Transportation (WSDOT) and the railroad company. These agreements specify the design elements of the crossing, work that the railroad will perform on behalf of the project, payment terms, and legal provisions. It may also be necessary for WSDOT to obtain easements from the railroad company for new grade crossings on railroad property. The Headquarters (HQ) Railroad Liaison is responsible for facilitating highway project coordination with railroad companies, including developing agreements and obtaining WUTC approvals. Obtaining necessary approvals from the railroad company may take several months. Contact the HQ Railroad Liaison early in the design phase so that all necessary design and agreement coordination can be completed according to project schedules.

More information about general railroad coordination and WUTC requirements is provided in Chapter 3 of the *Utilities Manual*.

## 1350.02 References

### (1) Federal/State Laws and Codes

Revised Code of Washington (RCW) 81.53, Railroad crossings

☞ <http://apps.leg.wa.gov/rcw/default.aspx?cite=81.53>

Washington Administrative Code (WAC) 480-62-150, Grade crossing petitions

☞ <http://apps.leg.wa.gov/wac/default.aspx?cite=480-62-150>

### (2) Design Guidance

*Agreements Manual*, M 22-99, WSDOT

☞ <http://wwwi.wsdot.wa.gov/publications/manuals/m22-99.htm>

*Manual on Uniform Traffic Control Devices for Streets and Highways*, USDOT, FHWA; as adopted and modified by Chapter 468-95 WAC “Manual on uniform traffic control devices for streets and highways” (MUTCD)

☞ [www.wsdot.wa.gov/publications/manuals/mutcd.htm](http://www.wsdot.wa.gov/publications/manuals/mutcd.htm)

*Standard Plans for Road, Bridge, and Municipal Construction (Standard Plans)*, M 21-01, WSDOT

☞ [www.wsdot.wa.gov/publications/manuals/m21-01.htm](http://www.wsdot.wa.gov/publications/manuals/m21-01.htm)

### (3) Supporting Information

*A Policy on Geometric Design of Highways and Streets (Green Book)*, AASHTO

*Guidance On Traffic Control Devices At Highway-Rail Grade Crossings*, Highway/Rail Grade Crossing Technical Working Group (TWG), FHWA, November 2002

☞ <http://safety.fhwa.dot.gov/xings/collision/twgreport/>

*Railroad-Highway Grade Crossing Handbook*, FHWA, August 2007

☞ [http://safety.fhwa.dot.gov/xings/com\\_roaduser/07010/](http://safety.fhwa.dot.gov/xings/com_roaduser/07010/)

*Manual on Uniform Traffic Control Devices Part 8. Traffic Control for Railroad and Light Rail Transit Grade Crossings*

☞ [http://mutcd.fhwa.dot.gov/hm/2009/part8/part8\\_toc.htm](http://mutcd.fhwa.dot.gov/hm/2009/part8/part8_toc.htm)

## 1350.03 Plans

### (1) Proposed Improvements

Include plans for proposed improvements to existing crossings and any new crossings in the Plans, Specifications, and Estimates (PS&E) package. In addition to basic roadway dimensions, signs, and markings, indicate the angle of crossing; number of tracks; location of signals and other railway facilities (such as electrical/communications lines and control boxes); and the limits of property ownership by the railroad company at the crossing location.

For any project proposing to alter the horizontal or vertical alignment at a grade crossing, including grade separations, show the alignment and profile for both the railroad and the roadway for a minimum of 500 feet on all legs of the crossing. Show all other important features that might affect the safety, operation, and design of the crossing, such as nearby crossroads, driveways/entrances, buildings, and highway structures on the plans.

#### (a) Sight Distance

A railroad grade crossing is comparable to the intersection of two highways where a sight triangle is kept clear of obstructions or it is protected by a traffic control device. The desirable sight distance allows a driver to see an approaching train at a distance that allows the vehicle to stop well in advance of the crossing if signals, or gates and signals, are not present (see [Exhibit 1350-1](#), Case 2). Sight distances of the order shown are desirable at any railroad grade crossing not controlled by railroad flashing light signals or gates (active warning devices). Attainment of optimal sight distances is often difficult and impracticable due to topography and terrain. Even in flat, open terrain, the growth of crops or other seasonal vegetation can create a permanent or seasonal sight distance obstruction. Furthermore, the properties upon which obstructions might exist are commonly owned by the railroad or others. Evaluate installation of active devices at any location where adequate sight distances cannot be provided. Include communication with the railroad and the WUTC in your evaluation.

The driver of a vehicle stopped at a crossing with signal lights but no gates needs to be able to see far enough down the tracks from the stop bar to be able to cross the tracks before a train, approaching at maximum allowable speed, reaches the crossing (see [Exhibit 1350-1](#), Case 1).

#### (b) Highway Grade and Crossing Angle

Construct highway grades so that low-clearance vehicles do not hang up on tracks or damage them. (See [Chapter 1220](#) for information on vertical alignment at railroad grade crossings.) Whenever possible, design the roadway to cross grade crossings at right angles. If bicycle traffic uses the crossing (this can be assumed for most roads), provide a shoulder through the grade crossing at least as wide as the approach shoulder width. If a skew is unavoidable, wider shoulders may be needed to permit bicycles to maneuver to cross the tracks at right angles. (See [Chapter 1520](#) for information on bikeways crossing railroad tracks.) Consider installation of advance warning signs indicating the presence of a skewed crossing for crossings where engineering judgment suggests a benefit.

Include any engineering studies or sight distance measurements in the Design Documentation Package (DDP).

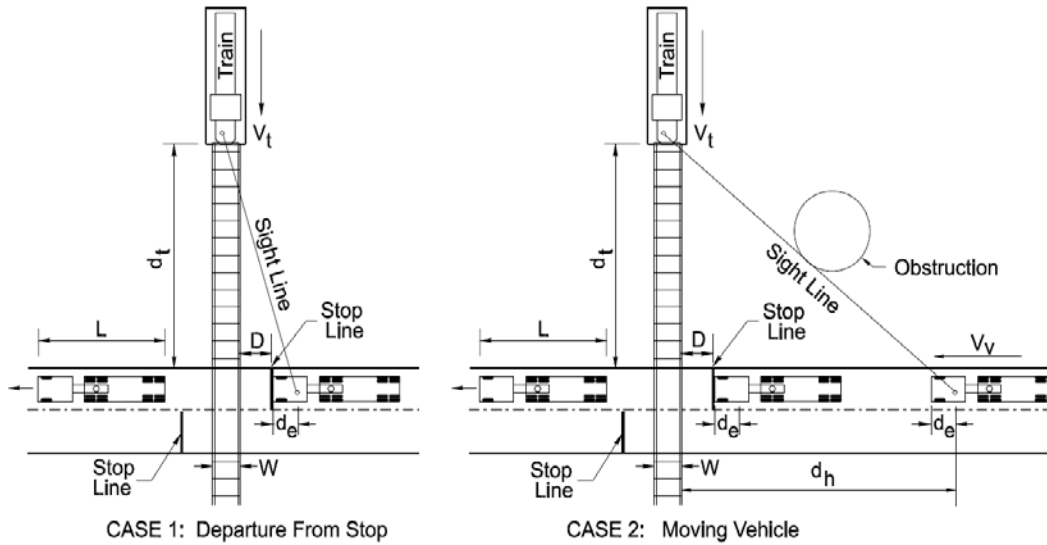

- $d_t$  = Sight distance along railroad tracks (ft)
- $d_h$  = Sight distance along highway (ft)
- $d_e$  = Distance from driver to front of vehicle (8 ft)
- $D$  = Distance from stop line to nearest rail (15 ft)
- $W$  = Distance between outer rails (single track  $W=5$  ft)
- $V_v$  = Velocity of vehicle (mph)
- $f$  = Coefficient of friction
- $V_t$  = Velocity of train (mph)
- $L$  = Length of vehicle (65 ft)

**Notes:**

- Adjust for skewed crossings.
- Assume flat highway grades adjacent to and at crossings.

Train Speed (mph) $V_t$	Case 1: Departure From Stop	Case 2: Moving Vehicle						
		Vehicle Speed (mph) $V_v$						
		10 $f=0.40$	20 0.40	30 0.35	40 0.32	50 0.30	60 0.29	70 0.28
<b>Distance Along Railroad From Crossing <math>d_t</math> (ft)</b>								
10	240	146	106	99	100	105	111	118
20	480	293	212	198	200	209	222	236
30	721	439	318	297	300	314	333	355
40	961	585	424	396	401	419	444	473
50	1,201	732	530	494	501	524	555	591
60	1,441	878	636	593	601	628	666	706
70	1,681	1,024	742	692	701	733	777	828
80	1,921	1,171	848	791	801	833	888	946
90	2,162	1,317	954	890	901	943	999	1,064
<b>Distance Along Highway From Crossing <math>d_h</math> (ft)</b>								
		69	135	220	324	447	589	751

Design sight distance for a combination of highway and train vehicle speeds and a 65-ft truck crossing a single set of tracks at 90° (AASHTO).

Source: *A Policy on Geometric Design of Highway and Streets*, 2004, by the American Association of State Highway and Transportation Officials.

**Sight Distance at Railroad Crossing**  
*Exhibit 1350-1*



## (6) Collector-Distributor (C-D) Roads

A C-D road can be within a single interchange, through two closely spaced interchanges, or continuous through several interchanges. Design C-D roads that connect three or more interchanges to be two lanes wide. Other C-D roads may be one or two lanes in width, depending on capacity. Consider intermediate connections to the main line for long C-D roads.

- (a) [Exhibit 1360-15a](#) shows the designs for collector-distributor outer separations. Use Design A, with concrete barrier, when adjacent traffic in either roadway is expected to exceed 40 mph. Design B, with mountable curb, may be used when adjacent posted speed does not exceed 40 mph.
- (b) The details shown in [Exhibit 1360-15b](#) apply to single-lane C-D road off-connections. Design a two-lane C-D road off-connection, with the reduction of a freeway lane or an auxiliary lane, as a normal two-lane off-connection in accordance with [1360.06\(5\)](#).
- (c) Design C-D road on-connections in accordance with [Exhibit 1360-15c](#).

## (7) Loop Ramp Connections

Loop ramp connections at cloverleaf interchanges are distinguished from other ramp connections by a low-speed ramp on-connection, followed closely by an off-connection for another low-speed ramp. The loop ramp connection design is shown in [Exhibit 1360-16](#). The minimum distance between the ramp connections is dependent on a weaving analysis. When the connections are spaced far enough apart that weaving is not a consideration, design the on-connection in accordance with [1360.06\(4\)](#) and the off-connection in accordance with [1360.06\(5\)](#).

## (8) Weaving Sections

Weaving sections may occur within an interchange, between closely spaced interchanges, or on segments of overlapping routes. [Exhibit 1360-12](#) gives the length of the weaving section for preliminary design. The total weaving traffic is the sum of the traffic entering from the ramp to the main line and the traffic leaving the main line to the exit ramp in equivalent passenger cars. For trucks, a passenger car equivalent of two may be estimated. Use the *Highway Capacity Manual* for the final design of weaving sections.

Because weaving sections cause considerable turbulence, interchange designs that eliminate weaving or remove it from the main roadway are desirable. Use C-D roads for weaving between closely spaced ramps when adjacent to high-speed highways. C-D roads are not needed for weaving on low-speed roads.

## 1360.07 Ramp Terminal Intersections at Crossroads

Design ramp terminal intersections at grade with crossroads as intersections at grade (see [Chapter 1300](#)). Whenever possible, design ramp terminals to discourage wrong-way movements. Locate ramp terminal intersections at grade with crossroads to provide signal progression if the intersection becomes signalized in the future. Provide intersection sight distance as described in [Chapter 1310](#) or [1320](#).

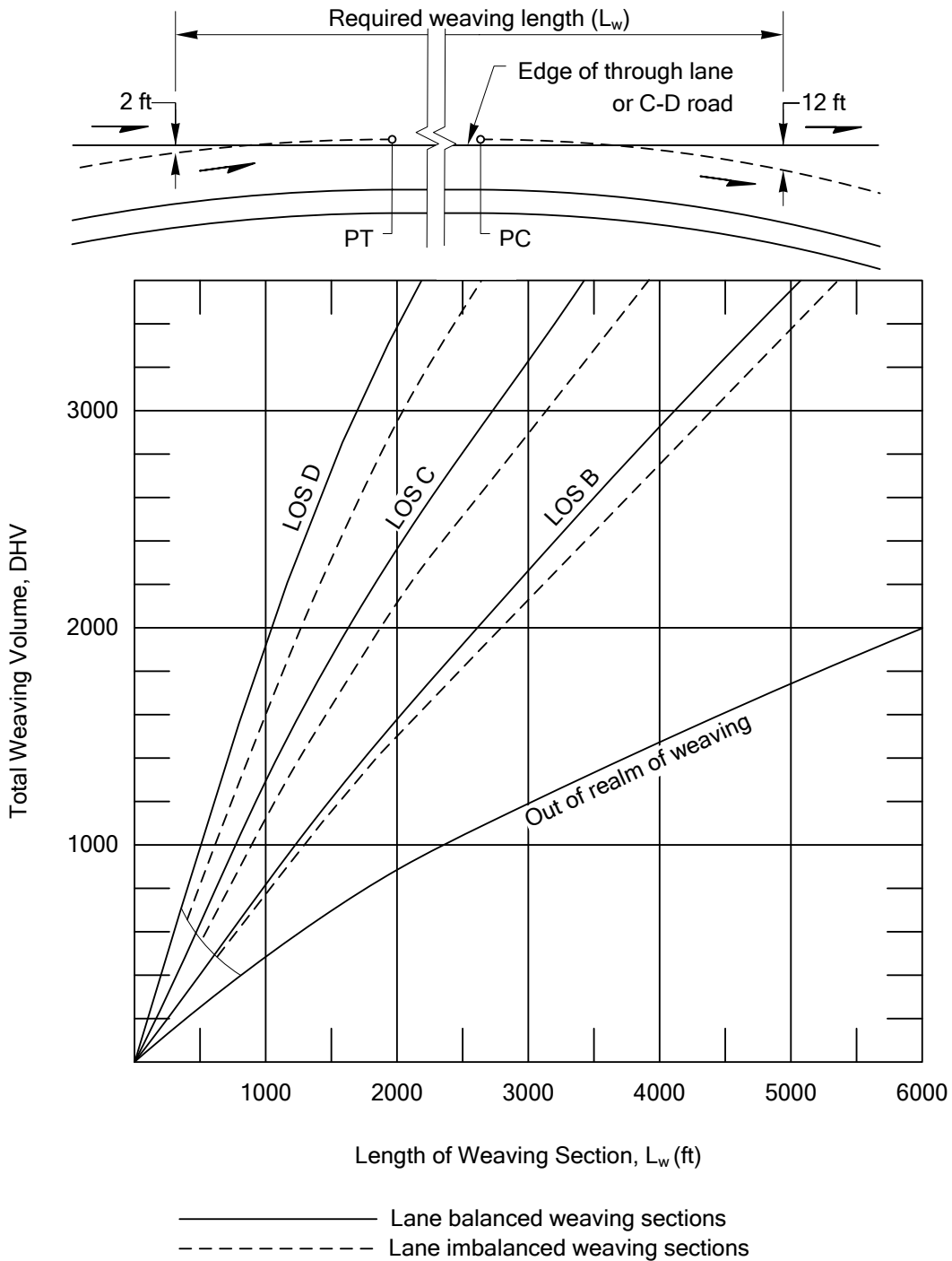

**Note:**

To determine whether or not lane balance for weaving exists, see [Exhibit 1360-8](#).

**Length of Weaving Sections**  
Exhibit 1360-12

## 1360.08 Interchanges on Two-Lane Highways

Occasionally, the first stage of a conventional interchange will be built with only one direction of the main roadway and operated as a two-lane two-way roadway until the ultimate roadway is constructed.

The design of interchanges on two-lane two-way highways may vary considerably from traditional concepts due to the following conditions:

- The potential for cross-centerline collisions due to merge conflicts or motorist confusion.
- The potential for wrong-way or U-turn movements.
- Future construction considerations.
- Traffic type and volume.
- The proximity to multilane highway sections that might influence a driver's impression that these roads are also multilane.

Provide the deceleration taper for all interchange exit ramps on two-lane highways. Design the entering connection with either the normal acceleration taper or a "button hook" configuration with a stop condition before entering the main line. Consider the following items:

- Design the stop condition connection in accordance with a tee (T) intersection as shown in [Chapter 1310](#). Use this type of connection when an acceleration lane is not possible. Provide decision sight distance as described in [Chapter 1260](#).
- Since designs may vary from project to project, analyze each project for the most efficient signing placement, such as one-way, two-way, no passing, do not enter, directional arrows, guideposts, and traffic buttons.
- Prohibit passing through the interchange area on two-lane highways by means of signing, pavement marking, or a combination of both. The desirable treatment is a 4-foot median island, highlighted with raised pavement markers and diagonal stripes. When using a 4-foot median system, extend the island 500 feet beyond any merging ramp traffic acceleration taper. The width for the median can be provided by reducing each shoulder 2 feet through the interchange (see [Exhibit 1360-17](#)).
- Include signing and pavement markings to inform both the entering and through motorists of the two-lane two-way characteristic of the main line.
- Use as much of the ultimate roadway as possible. Where this is not possible, leave the area for future lanes and roadway ungraded.
- Design and construct temporary ramps as if they were permanent unless second-stage construction is planned to rapidly follow the first stage. Design the connection to meet the needs of the traffic.

## 1360.09 Interchange Plans for Approval

[Exhibit 1360-18](#) is a sample showing the general format and data for interchange design plans.

Compass directions (W-S Ramp) or crossroad names (E-C Street) may be used for ramp designations.

Include the following, as applicable:

- Classes of highway and design speeds for main line and crossroads (see [Chapter 1140](#)).
- Curve data on main line, ramps, and crossroads.
- Numbers of lanes and widths of lanes and shoulders on main line, crossroads, and ramps.
- Superelevation diagrams for the main line, the crossroad, and all ramps; these may be submitted on separate sheets.
- Channelization.
- Stationing of ramp connections and channelization.
- Proposed right of way and access control treatment (see [Chapters 510, 520, and 530](#)).
- Delineation of all crossroads, existing and realigned.
- Traffic data for the proposed design; include all movements.
- For HOV direct access connections on the left, include the statement that the connection will be used solely by HOVs or will be closed.

Prepare a preliminary contour grading plan for each completed interchange. Show the desired contours of the completed interchange, including details of basic land formation, slopes, graded areas, or other special features. Coordinate the contour grading with the drainage design and the roadside development plan.

## 1360.10 Documentation

Refer to [Chapter 300](#) for design documentation requirements.

- 1420.01 General
- 1420.02 References
- 1420.03 Definitions
- 1420.04 HOV Access Types and Locations
- 1420.05 Direct Access Geometrics
- 1420.06 Passenger Access
- 1420.07 Traffic Design Elements
- 1420.08 Documentation

### **1420.01 General**

This chapter provides Washington State Department of Transportation (WSDOT) design guidance for left-side direct access facilities for high-occupancy vehicles (HOVs) between freeway HOV lanes and flyer stops within the freeway right of way or facilities outside of the right of way. Design right-side HOV-only access facilities in accordance with [Chapter 1360](#).

Direct access eliminates the need for left-side HOV lane users to cross the general-purpose lanes to right-side general-purpose ramps. Also, transit vehicles can use the HOV lane and provide service to the HOV direct access facility.

Providing the HOV user access to the inside HOV lane without mixing with the general-purpose traffic saves the user additional travel time and aids in safety, enforcement, incident handling, and overall operation of the HOV facility.

Locations for direct access ramps include HOV facilities on intersecting routes, park & ride lots, flyer stops, and locations with a demonstrated demand. Coordinate with the local transit agencies to identify these key locations. Give priority to locations that serve the greatest number of transit vehicles and other HOVs.

#### **1420.01(1) Existing Facilities**

Design HOV direct access facilities such that they do not degrade the existing general-purpose facilities.

When an HOV direct access facility project includes work on the existing facilities, apply the guidance from the New/Reconstruction row of the Interstate Design Matrices and the HOV row of the other matrices in [Chapter 1100](#).

#### **1420.01(2) Reviews, Studies, and Reports**

The normal project development process is to be followed when developing an HOV direct access project. Despite the unusual nature of the projects that are the focus of this chapter, most facets of the project development process remain unchanged. For example, early coordination with others is a vital part of developing a project. There are also environmental considerations, public involvement, and value engineering studies (see [Chapter 310](#)). There may also be reviews, studies, and reports required by agreements with regional transit authorities or other agencies.

Provide an interchange justification report (see [Chapter 550](#)) when there is a proposal to add, delete, or change an access point. Provide the operational analysis from the report for all flyer stops. For left-side connections, include the commitment that the connection will be used solely by HOVs or will be closed.

Throughout the project development phase, make sure the project:

- Definition and cost estimate are correct.
- Development process is on schedule.
- Documents are biddable.
- Will be constructable.
- Will be maintainable.

Constructability of HOV direct access facilities is an important consideration during the design phase. These facilities will typically be constructed on existing highways with traffic maintained on-site. Key goals are to:

- Provide a project that can be built.
- Plan a construction strategy.
- Provide a safe work zone.
- Minimize construction delays.

Consider access to these facilities by maintenance crews. Avoid items that require a significant maintenance effort and might result in lane closure for routine maintenance or repair.

### **1420.01(3) Left-Side Connections**

Left-side connections are allowed only when they serve HOVs exclusively and connect to an HOV lane. The higher traffic volume associated with general-purpose traffic is not acceptable for left-side connections. If the demand for an HOV direct access decreases to the point that the HOV direct access connection is no longer desirable, the connection must be closed.

## **1420.02 References**

### **1420.02(1) Federal/State Laws and Codes**

Americans with Disabilities Act of 1990 (ADA)

*ADA Accessibility Guidelines for Buildings and Facilities (ADAAG)*, The Access Board

🌐 [www.access-board.gov/adaag/html/adaag.htm](http://www.access-board.gov/adaag/html/adaag.htm)

[Washington Administrative Code \(WAC\) 468-510-010](#), High occupancy vehicles (HOV)

### **1420.02(2) Design Guidance**

*Manual on Uniform Traffic Control Devices for Streets and Highways*, USDOT, FHWA; as adopted and modified by [Chapter 468-95 WAC](#) “Manual on uniform traffic control devices for streets and highways” (MUTCD)

*Sign Fabrication Manual*, M 55-05, WSDOT

*Standard Plans for Road, Bridge, and Municipal Construction (Standard Plans)*, M 21-01, WSDOT

### 1420.02(3) Supporting Information

*A Policy on Geometric Design of Highways and Streets (Green Book)*, AASHTO

FHWA/PB, *HOV Interactive 1.0 High Occupancy Vehicle Data Base from the U.S., Canada and Europe* (CD ROM), USDOT, FHWA and Parsons Brinkerhoff

*Bus Use of Highways: Planning and Design Guidelines*, NCHRP 155

*Guide for the Design of High-Occupancy Vehicle (HOV) Facilities*, AASHTO

*High-Occupancy Vehicle Facilities: A Planning, Design, and Operation Manual*, Parsons Brinkerhoff

*HOV Systems Manual*, NCHRP 414

“Transit Implications of HOV Facility Design,” WA-RD 396.1, September 1996, WSDOT and USDOT, Federal Transit Administration

### 1420.03 Definitions

For definitions of many of the terms in this chapter, see the [Design Manual Glossary](#).

### 1420.04 HOV Access Types and Locations

To provide direct access for high-occupancy vehicles from the HOV lane to a passenger loading facility, there are many options and many constraints. Following are some of the options (selected as being usable on Washington’s freeways) and constraints regarding their use.

To select an option, first establish the need, choose possible locations, evaluate site features (such as terrain, existing structures, median widths), and evaluate existing HOV information (such as lanes, park & ride facilities, transit routes and schedules, and origin and destination studies). Choose a location that meets access point spacing requirements and will not degrade traffic operations on the main line.

Important constraints to transit stop designs are:

- Passenger access routes and waiting areas are separated from freeway traffic.
- Passenger access to a bus is on its right side only.
- Passenger access to a loading platform must accommodate the disabled.

#### 1420.04(1) Freeway Ramp Connection Locations

##### 1420.04(1)(a) Spacing

For minimum ramp connection spacing, see [Chapter 1360](#). When evaluating the spacing of left-side direct access ramps, include only left-side connections.

Traffic operations can be degraded by the weaving caused by a left-side on-connection followed closely by a right-side off-connection (or a right-side on-connection followed by a left-side off-connection). As a general rule, if the spacing between the HOV direct access ramp and the general-purpose ramp is less than one gap acceptance length (see [1420.05\(6\)\(c\)](#)) per lane, make the HOV lane buffer-separated (see [Chapter 1410](#)).

Conduct an analysis to make certain that the new ramp will not degrade traffic operations. (See [Chapter 550](#) for the studies and report required for a new access point.)

When an off-connection follows an on-connection, provide full speed-change lane lengths and tapers or at least sufficient distance for full speed-change lanes that connect at full width with no tapers (see [1420.05\(6\)](#) and [\(7\)](#)). An auxiliary lane can be used to connect full-width speed-change lanes if there is not sufficient distance for both tapers.

#### **1420.04(1)(b) Sight Distance**

Locate both on- and off-connections to the main line where decision sight distance exists on the main line (see [Chapter 1260](#)).

#### **1420.04(2) Ramp Terminal Locations**

##### **1420.04(2)(a) Local Streets and Roads**

Access to the HOV lane can be provided by a ramp that terminates at a local street or road. The local street or road may incorporate HOV lanes, but they are not required. (See [1420.07](#) for signing and pavement markings.)

Consider traffic operations on the local road. Locate the terminal where:

- It has the least impact on the local road.
- Intersection spacing criteria are satisfied.
- Queues from adjacent intersections do not block the ramp.
- Queues at the ramp do not block adjacent intersections.
- Wrong-way movements are discouraged.

When off-ramps and on-ramps are opposite each other on the local road, consider incorporating a transit stop with the intersection.

##### **1420.04(2)(b) Park & Ride Lots**

HOV direct access ramps that connect the HOV lane with a park & ride lot provide easy access for express transit vehicles between the HOV lane and a local service transit stop at the park & ride facility. Other HOV traffic using the access ramp enters through the park & ride lot, which can create operational conflicts.

##### **1420.04(2)(c) Flyer Stops**

Median flyer stops do not provide general access to the HOV lane. Access is from the HOV lane to the transit stop and back to the HOV lane. No other vehicle access is provided. Ramps to and from the flyer stops are restricted to transit vehicles only.

#### **1420.04(3) Ramp Types**

##### **1420.04(3)(a) Drop Ramps**

Drop ramps are generally straight, stay in the median, and connect the HOV lane with a local road or flyer stop. Following is a photo and an example of a drop ramp.





Drop ramp photograph from FHWA/PB HOV Interactive 1.0  
High Occupancy Vehicle Data Base from the U.S., Canada, and Europe

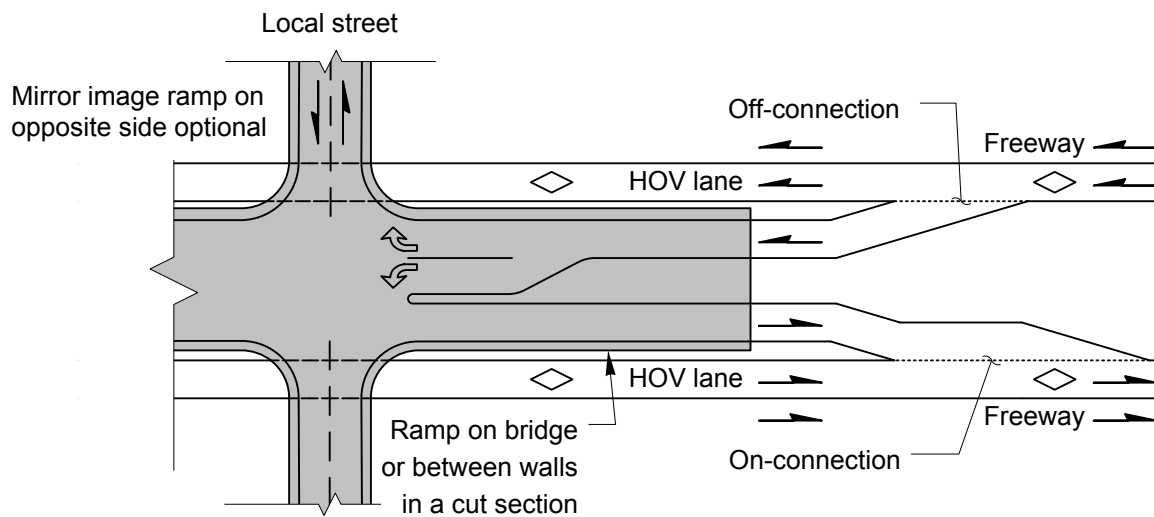

Consider this example for gore area characteristics for drop ramps:

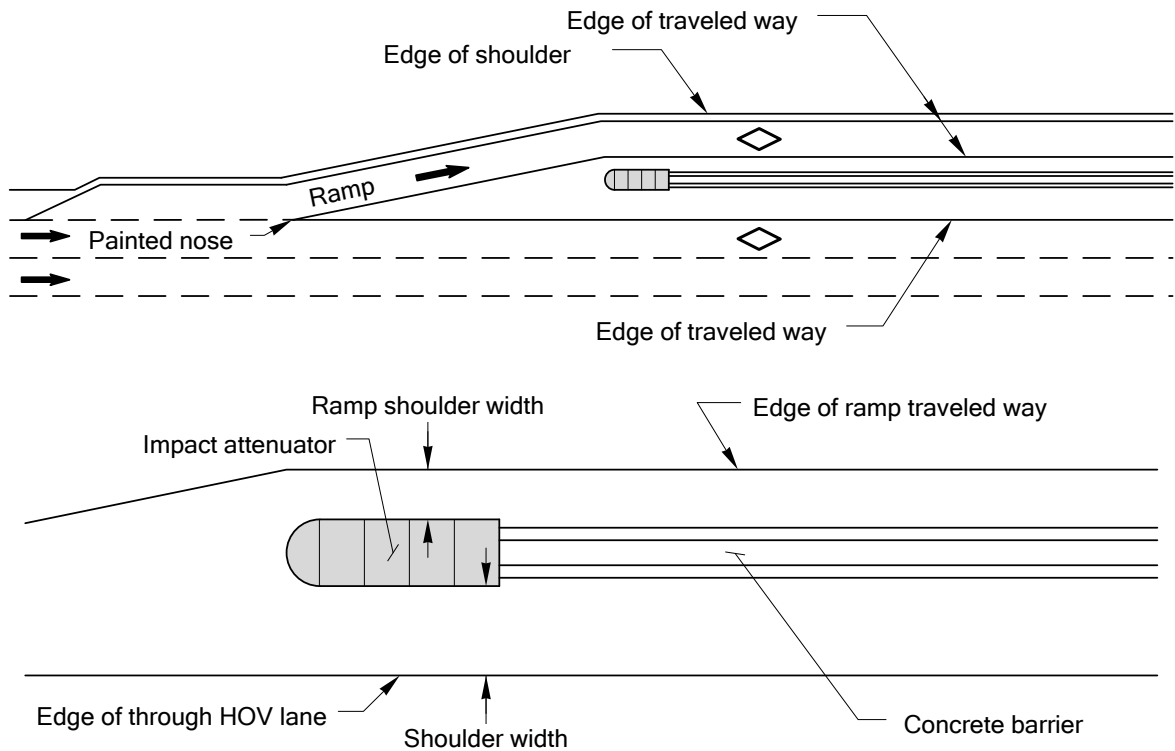

**1420.04(3)(b) T Ramps**

A T ramp is a median ramp that serves all four HOV access movements and comes to a T intersection within the median, usually on a structure. The structure then carries the HOV ramp over the freeway to a local road or directly to a park & ride lot. Through traffic is not permitted at the T ramp; therefore, flyer stops are not allowed. A photo and an example of a T ramp are shown for reference. Also, refer to [1420.05\(10\)](#) for added design information.



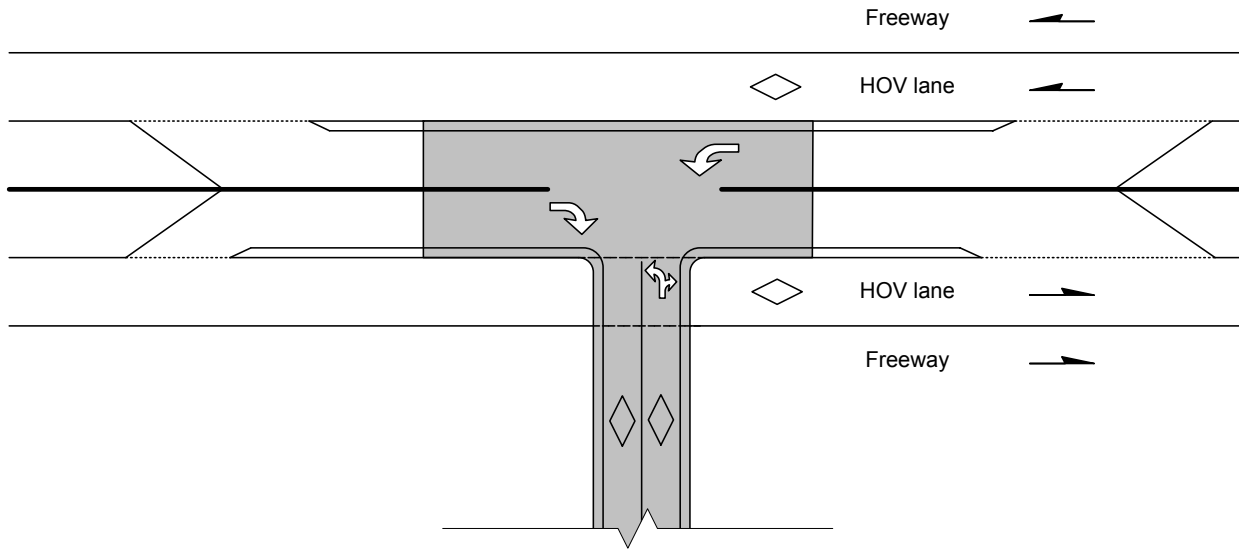

**1420.04(3)(c) Flyover Ramps**

A flyover ramp is designed to accommodate high-speed traffic by using flat curves as the ramp crosses from the median over one direction of the freeway to a local road, a park & ride lot, or an HOV lane on another freeway. A photo and an example of a flyover ramp are shown.



*Flyover ramp photograph from FHWA/PB HOV Interactive 1.0 High Occupancy Vehicle Data Base from the U.S., Canada, and Europe*

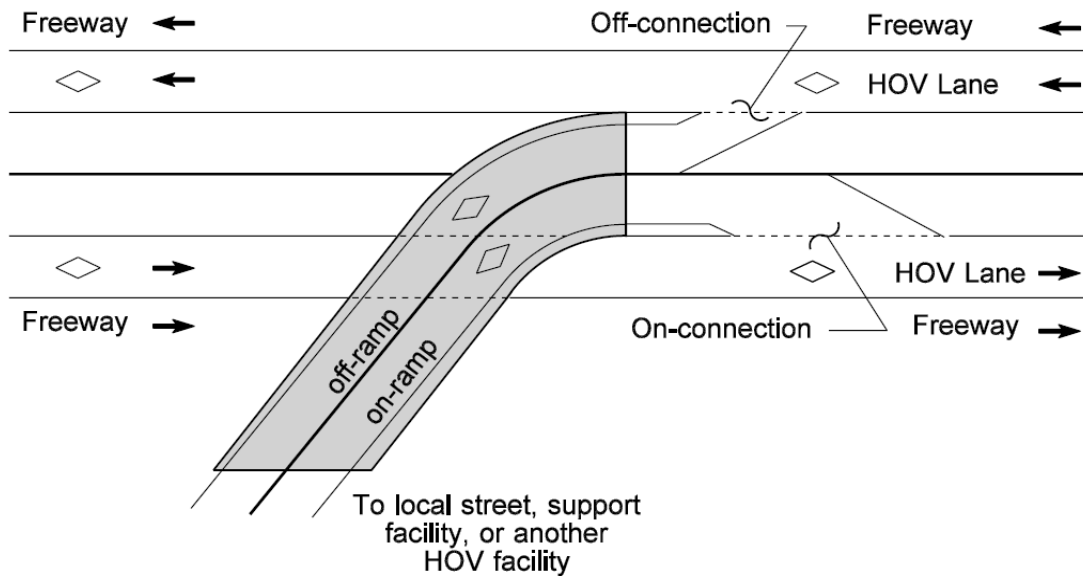

**1420.04(4) Transit Stops**

**1420.04(4)(a) Flyer Stops**

Flyer stops are transit stops inside the limited access boundaries for use by express transit vehicles using the freeway. They may be located in the median at the same grade as the main roadway or on a structure, on a ramp, or on the right side of the main line.

The advantage of a median flyer stop is that it reduces the time for express transit vehicles to serve intermediate destinations. A disadvantage is that passengers travel greater distances to reach the loading platform.

With left-side HOV lanes, flyer stops located on the right side increase the delay to the express transit vehicles by requiring them to cross the general-purpose lanes. However, these stops improve passenger access from that side of the freeway.

For additional design information, see [Chapter 1430](#).

**1. Side-Platform Flyer Stops**

Side-platform flyer stops are normally located in the median and have two passenger loading platforms: one on each side between the bus loading lane and the through HOV lane. This design provides the most direct movement for the express transit vehicle and is the desirable design for median flyer stops.

This design is relatively wide. Where space is a concern, consider staggering the loading platforms longitudinally.

Consider tall barrier to divide the directions of travel or staggering the loading platforms to discourage unauthorized at-grade movement of passengers from one platform to the other (see [1420.07\(1\)](#)). The side platform flyer stop with grade-separated access to each platform is the preferred design.

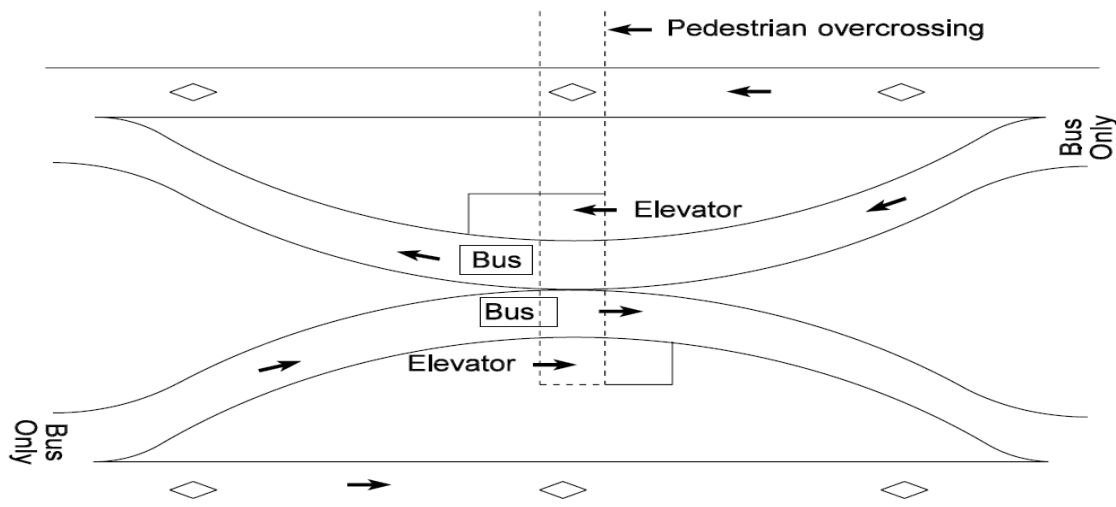

## 2. At-Grade Passenger Crossings

This design is similar to the side-platform flyer stop, except that passengers are allowed to cross, from one platform to the other, at grade. This design might eliminate the need for passenger access to one of the loading platforms with a ramp or an elevator, and it simplifies transfers. The passenger crossing necessitates providing a gap in the barrier for the crosswalk. Only transit vehicles are allowed. Passenger/pedestrian accommodations must comply with the ADA.



*At-grade passenger crossing photograph from FHWA/PB HOV Interactive 1.0 High Occupancy Vehicle Data Base from the U.S., Canada, and Europe*

Consider an at-grade passenger crossing flyer stop only when passenger volumes are expected to be low. Design at-grade passenger crossing flyer stops as the first stage of the stop, with the ultimate design being side-platform flyer stops with grade-separated access to both platforms.

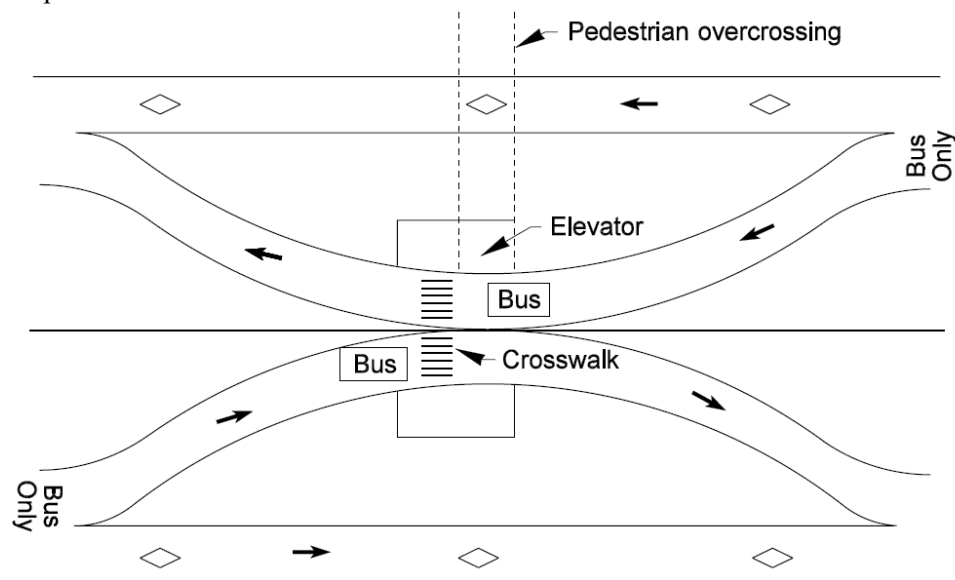

## 3. Ramp Flyer Stops

When ramp flyer stops are located on an HOV direct access drop ramp, the delay for the express transit vehicle will not be much more than for a median stop, and passenger access and connectivity to local service transit routes, on the local street or road, are improved. A flyer stop on a right-side ramp works well with right-side HOV lanes and diamond interchanges in which express transit vehicles can use the off-ramp to connect with a bus route on the local road and the on-ramp to return to the HOV lane. However, a stop on a general-purpose right-side ramp with a left-side HOV lane will increase the delay by requiring the express transit vehicle to use the general-purpose lanes and possibly degrade main line traffic operations by increasing weaving movements.

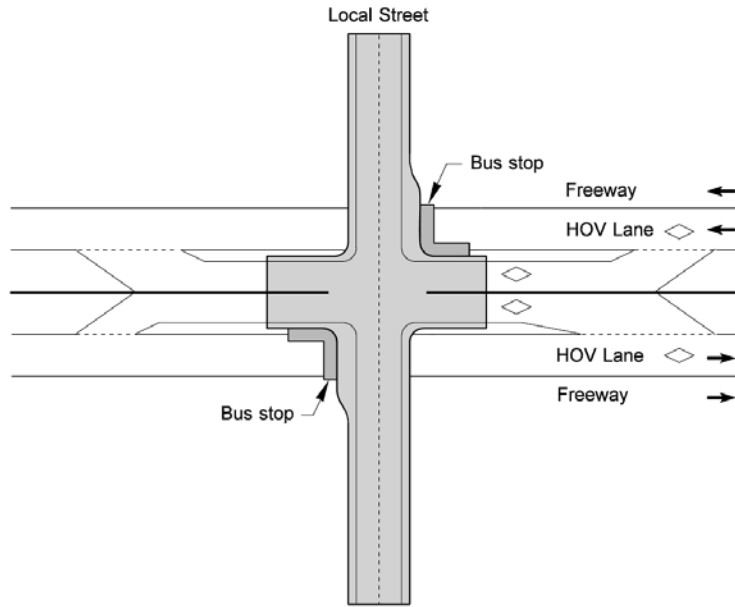

**1420.04(4)(b) Off-Line Transit Stops**

**1. Park & Ride Stops**

Transit stops located at park & ride lots provide transfer points between the express transit system and the local transit system, and there is convenient passenger access to the park & ride lot. When a direct access ramp is provided, express transit delays from the HOV lane to the stop are reduced. These delays can be reduced more by providing a median flyer stop with passenger access facilities connecting the park & ride lot to the flyer stop; however, this might be more inconvenient for the passengers.

**2. Stops at Flyer Stop Passenger Access Points**

To minimize the passenger travel distance between express and local service transit stops, locate local system transit stops near passenger access facilities for the flyer stops.

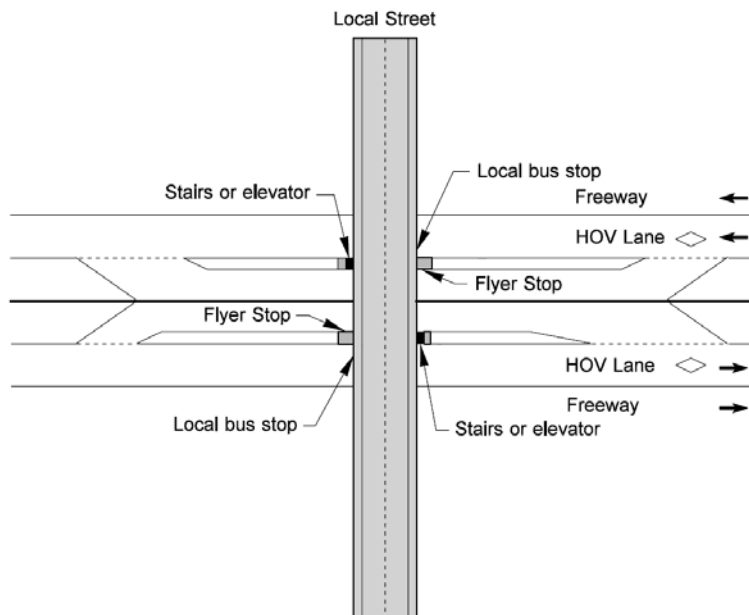

### 1420.04(5) Enforcement Areas

Enforcing the vehicle occupancy requirement helps the HOV facilities function as intended. Law enforcement officers need areas for observation that are near pull-out areas, where both the violator and the officer can pull safely out of the traffic flow.

Consider locating observation and pull-out areas near any point where violators can enter or exit an HOV direct access facility. Examples of potential locations are:

- Freeway on- and off-connections for HOV direct access ramps.
- HOV direct access ramp terminals at parking lots.

For freeway HOV lanes, locate enforcement areas on the adjacent shoulders so officers and violators are not required to cross several lanes of traffic.

Enforcement area guidance and designs are in [Chapter 1410](#).

### 1420.05 Direct Access Geometrics

HOV direct access ramps are different than other ramps because they are usually on the left side of the through lanes and they have a high percentage of buses. Design right-side HOV direct access using the procedures given in [Chapter 1360](#). The following procedures are for the design of left-side HOV direct access.

Because left-side ramps are rare and therefore less expected, signing is an important issue. (For signing guidance, see [1420.07\(2\)](#).)

When the bus percentage is high, there are several considerations:

- When a bus enters the through lanes from the left, the driver has a relatively poor view of the through traffic.
- A bus requires a longer distance to accelerate than other vehicles.
- A bus requires a longer deceleration length for passenger comfort.

#### 1420.05(1) Design Vehicles

Use the following design vehicles for left-side HOV direct access facilities:

- Use AASHTO's A BUS vehicle for horizontal design.
- Use AASHTO's SU-30 vehicle for vertical design.
- Use AASHTO's P vehicle for stopping sight distance.

Refer to Chapters [1300](#) and [1430](#), and the *AASHTO Green Book* for vehicle descriptions and dimensions. Use turn simulation software (such as AutoTURN<sup>®</sup>) to verify turning movements.

#### 1420.05(2) Design Speeds

Refer to [Chapter 1360](#) for the design speeds for ramps. Use the design speed of the general-purpose lanes for the main line design speed.

**1420.05(3) Sight Distance**

Provide stopping sight distance in accordance with [Chapter 1260](#). This provides sight distance for an automobile. The longer distance needed for a bus to stop is compensated for by the greater eye height of the driver, with the resulting vertical curve length about equal to that for an automobile.

Sag vertical curves may be shortened where necessary. (See [Chapter 1220](#) for guidance.)

**1420.05(4) Grades**

Grades for ramps are covered in [Chapter 1360](#). Deviations will be considered for:

- Downgrade on-ramps with grades increased by an additional 1%.
- Upgrade off-ramps with grades increased by an additional 2%.

These increased grades help when geometrics are restricted, and they assist transit vehicles with the acceleration when entering and the deceleration when exiting the freeway.

**1420.05(5) Ramp Widths****1420.05(5)(a) Lane Widths**

Use widths for separated roadway HOV facilities. (See Minimum Traveled Way Widths for Articulated Buses in [Chapter 1410](#).) On tangents, the minimum lane width may be reduced to 12 feet.

**1420.05(5)(b) Shoulder Widths**

Ramp shoulder width criteria are modified as follows:

- The minimum width for the sum of the two shoulders is 10 feet for one-lane ramps and 12 feet for two or more lanes.
- The minimum width for one of the shoulders is 8 feet for disabled vehicles. The minimum width for the other shoulder is 2 feet. (See [Chapter 1610](#) for shy distance at barrier.)
- The wider shoulder may be on the left or the right. Maintain the wide shoulder on the same side throughout the ramp.

Minimum Ramp Widths for Articulated Buses	
R (ft)*	W <sub>R</sub> (ft)
Tangent	21
500	23
400	23
300	24
200	26
150	27
100	30
75	34
50	40
*R is to the curve inside edge of traveled way	

**1420.05(5)(c) Total Ramp Widths**

Make the total width of the ramp (lane width plus shoulders) wide enough to allow an A-BUS to pass a stalled A-BUS. This width has two components:

- The vehicle width (U = 8.5 feet on tangent) for each vehicle
- Lateral clearance (C = 2 feet) for each vehicle

The vehicle width and the lateral clearance are about the width of an A-BUS from edge of mirror to edge of mirror.



The table above gives the minimum ramp width ( $W_R$ ), including shoulders, at various radii ( $R$ ) for an articulated bus. For ramp locations on a tangent section or on a curve with a radius greater than 150 feet, consider the  $W_R$  width when requesting a reduced lane or shoulder width. For ramp curves with a radius less than 150 feet, check the total ramp width and, if necessary, widen the shoulders to provide the  $W_R$  width.

### 1420.05(6) On-Connections

#### 1420.05(6)(a) Parallel On-Connections

For left-side on-connections, use the parallel on-connection.

A parallel on-connection adds a parallel lane that is long enough for the merging vehicle to accelerate in the lane and then merge with the through traffic. This merge is similar to a lane change and the driver can use side and rear view mirrors to advantage.

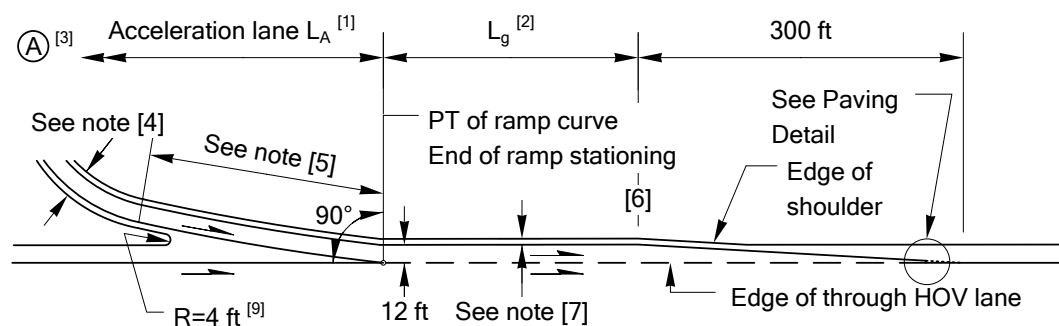

#### Notes:

- [1] For acceleration lane length  $L_A$ , see [1420.05\(6\)\(b\)](#). Check  $L_A$  for each ramp design speed.
- [2]  $L_g$  is the gap acceptance length. Begin  $L_g$  at the beginning of the parallel lane, as shown, but not before the end of the acceleration lane  $L_A$ . (See [1420.05\(6\)\(c\)](#) for the length  $L_g$ .)
- [3] Point  $\textcircled{A}$  is the point controlling the ramp design speed or the end of the transit stop zone or other stopping point.
- [4] For ramp lane and shoulder widths, see [1420.05\(5\)](#).
- [5] A transition curve with a minimum radius of 3,000 ft is desirable. The desirable length is 300 ft. When the main line is on a curve to the right, the transition may vary from a 3,000 ft radius to tangent to the main line. The transition curve may be replaced by a 50:1 taper with a minimum length of 300 ft.
- [6] Angle point for width transitions, when required. (See [Chapter 1210](#) for pavement transitions.)
- [7] For ramp shoulder width, see [1420.05\(5\)\(b\)](#).
- [8] The 10 ft left shoulder is the minimum width; 14 ft is desirable. Maintain this shoulder width for at least 500 ft; 1,000 ft is desirable.
- [9] Radius may be reduced when concrete barrier is placed between the ramp and main line.

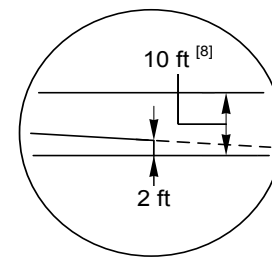

**Paving Detail**

#### General:

For striping, see the [Standard Plans](#).

**1420.05(6)(b) Acceleration Lanes**

The table below gives the minimum acceleration lane length ( $L_A$ ) for left-side HOV direct access on-connections.

The buses using HOV direct access ramps merge with high-speed traffic. Acceleration lanes that are longer than normally used are needed.

For left-side on-connections, consider at least the normal 10-foot-wide (14-foot desirable) left shoulder for the main line for a minimum length of 500 feet (1,000 feet desirable) beyond the end of the on-connection taper. This gives additional room for enforcement, merging, and erratic maneuvers.

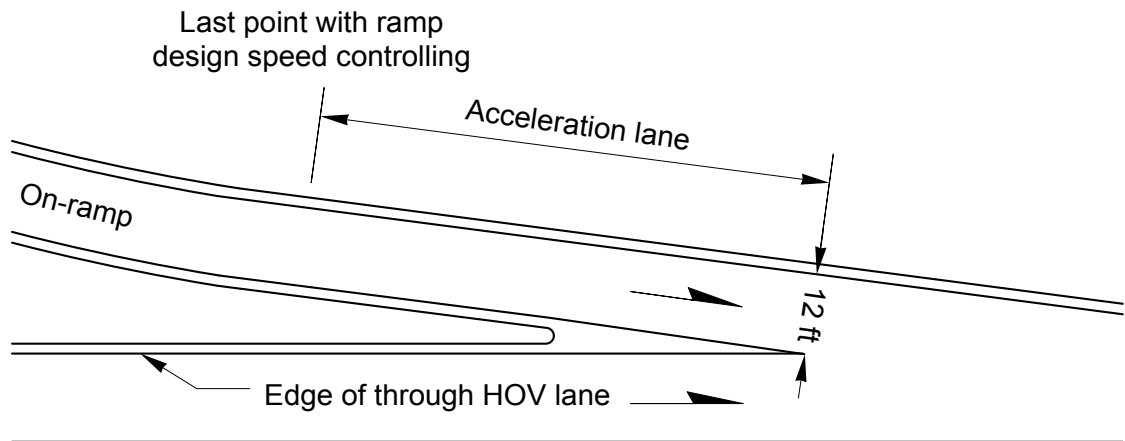

Freeway Speed (mph)	Ramp Design Speed								
	0	15	20	25	30	35	40	45	50
40	555	480	420	340	185				
45	835	760	700	615	470	290			
50	1,230	1,160	1,100	1,020	865	685	310		
55	1,785	1,715	1,655	1,575	1,420	1,235	875	410	
60	2,135	2,085	2,040	1,985	1,875	1,735	1,440	995	460
70	3,045	3,015	2,985	2,945	2,860	2,745	2,465	2,050	1,515
80	4,505	4,465	4,420	4,370	4,250	4,095	3,745	3,315	2,780
<b>Acceleration Length (<math>L_A</math>) for Buses (ft)</b>									
<b>Note:</b> For the adjustment factors for grade, see acceleration lane in <a href="#">Chapter 1360</a> .									

**1420.05(6)(c) Gap Acceptance Length**

Gap acceptance length is a minimum distance traveled while a merging driver finds a gap in the through traffic and begins the merge. For left-side parallel on-connections, the gap acceptance length is added to the acceleration length. The  $L_g$  values are given in the table below. These values are larger than for right-side on-connections to account for drivers' visibility constraints.

Highway Posted Speed (mph)	Gap Acceptance Length, $L_g$ (ft)
45	550
50	625
55	700
60	775
65	850
70	925

**1420.05(6)(d) Urban On-Connection Design**

Design left-side HOV direct access on-connections in urban areas as follows:

1. Use the parallel design for left-side on-connections.
2. Add the Gap Acceptance Length for Parallel On-Connections (see [1420.05\(6\)\(c\)](#)) for a freeway speed of 60 mph to the acceleration length.
3. Use Acceleration Length for Buses (see [1420.05\(6\)\(b\)](#)) with a 60 mph freeway speed and the ramp design speed (see [1420.05\(2\)](#)) for acceleration length.

**1420.05(6)(e) Rural On-Connection Design**

Design left-side HOV direct access on-connections in rural areas using a freeway design speed as given in [Chapter 1140](#).

**1420.05(7) Off-Connections****1420.05(7)(a) Parallel Off-Connection**

The parallel off-connection is desirable for left-side direct access off-connections. For freeway-to-freeway off-connections, provide a parallel lane with a length sufficient for signing and deceleration. The desirable minimum length is not less than the gap acceptance length (see [1420.05\(6\)\(c\)](#)).

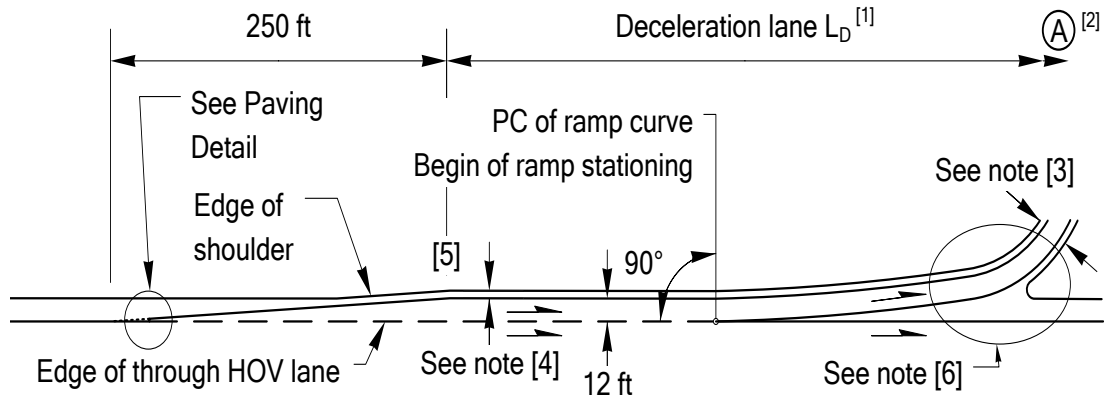
**Notes:**

- [1] For deceleration lane length  $L_D$ , see [1420.05\(7\)\(c\)](#). Check  $L_D$  for each ramp design speed.
- [2] Point  $\textcircled{A}$  is the point controlling the ramp design speed or the end of the transit stop zone or other stopping point.
- [3] For ramp lane and shoulder widths, see [1420.05\(5\)](#).
- [4] For ramp shoulder width, see [1420.05\(5\)\(b\)](#).
- [5] Angle point for width transitions, when required. (See [Chapter 1210](#) for pavement transitions.)
- [6] Gore area characteristics at drop ramp connections are shown on [1420.04\(3\)\(a\)](#). (See [Chapter 1360](#) for gore details at other connection types.)
- [7] The desirable shoulder width is 10 ft.

**General:**

For striping, see the *Standard Plans*.

**1420.05(7)(b) Tapered Off-Connection**

The tapered off-connection may be used, with justification. (See [Chapter 1360](#) for the design of tapered off-connections.)

**1420.05(7)(c) Deceleration Lanes**

Bus passenger comfort requires longer deceleration lanes. Use the deceleration lane lengths from the table below for HOV direct access facilities.

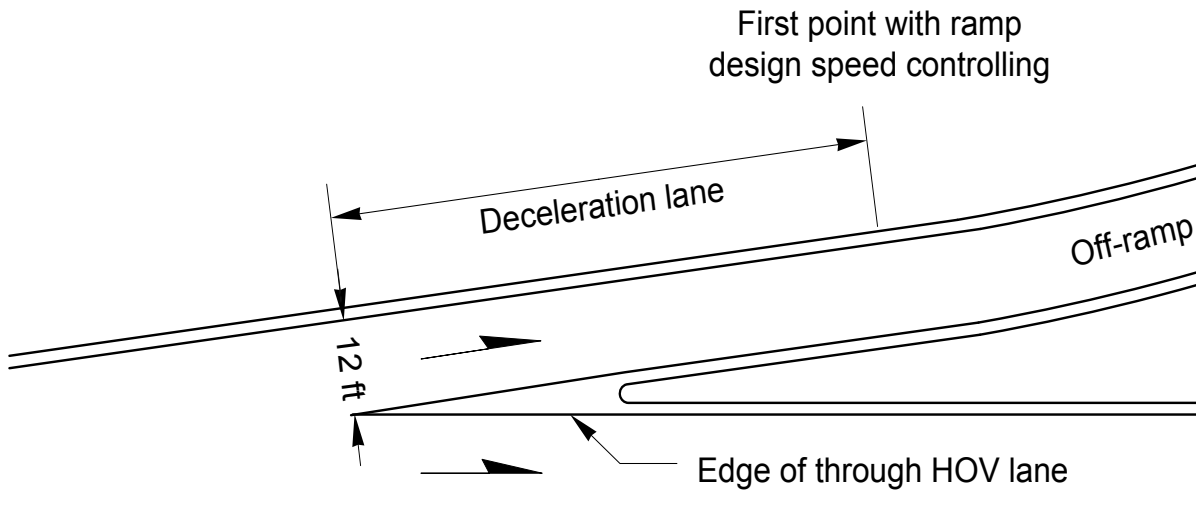

Highway Speed (mph)	Ramp Design Speed (mph)								
	0	15	20	25	30	35	40	45	50
40	390	330	290	240	170	100			
45	470	420	380	330	260	190	90		
50	570	520	480	430	360	290	190	100	
55	680	620	590	540	470	400	300	210	110
60	800	740	700	660	580	520	420	330	230
70	990	930	900	850	780	710	610	520	420
80	1,210	1,150	1,110	1,060	990	920	830	740	640

**Deceleration Length ( $L_D$ ) for Buses (ft)**

**Note:** For the adjustment factors for grade, see deceleration lane in [Chapter 1360](#).

**1420.05(7)(d) Urban Off-Connection Design**

Design left-side HOV direct access off-connections in urban areas as follows:

1. Either the parallel (desirable) or the taper (with justification) design may be used.
2. Use the longer deceleration length of: the Deceleration Length for Buses (see [1420.05\(7\)\(c\)](#)) from a 60 mph freeway speed to the ramp design speed (see [1420.05\(2\)](#)) or the Minimum Deceleration Length given in [Chapter 1360](#) from the freeway design speed to the ramp design speed.

**1420.05(7)(e) Rural Off-Connection Design**

Design left-side HOV direct access off-connections in rural areas using a freeway design speed as given in [Chapter 1140](#).

**1420.05(8) Vertical Clearance**

Vertical clearance for a structure over a road is measured from the lower roadway surface, including the usable shoulders, to the bottom of the overhead structure.

Refer to [Chapter 720](#) for information on vertical clearance. For a new structure, and for a new ramp under an existing structure, the minimum vertical clearance is 16.5 feet. A deviation will be considered for a 14.5-foot minimum vertical clearance for a new HOV direct access ramp under an existing bridge.

The minimum vertical clearance for a pedestrian grade separation over any road is 17.5 feet.

**1420.05(9) Flyer Stops**

Design flyer-stop ramp on-connections as given in [1420.05\(6\)](#), and design off-connections as given in [1420.05\(7\)](#). Flyer stop connections are included in the access point spacing discussed in [1420.04\(1\)\(a\)](#).

Design the ramp to the flyer stop in accordance with [1420.05\(3\)](#), [1420.05\(4\)](#), and [1420.05\(5\)](#).

The minimum width for the roadway at a flyer stop is 24 feet.

When a flyer stop is in the median, provide enough median width for the flyer stop roadway, passenger facilities, and barrier separation without reducing the width of the through lanes or shoulders (see [1420.06](#)).

The approval of a flyer stop requires the operational analysis portion of the interchange justification report (see [Chapter 550](#)).

**1420.05(10) Wrong-Way Driving Countermeasures**

The following bulleted items and examples are countermeasures for wrong-way driving at HOV direct access ramps:

- Provide a staggered traffic arrow to better describe the left and right turns.
- Provide pavement marking extensions, using wide lines, through intersections.
- Use redundant directional pavement arrows at ramp terminals.
- Paint or use reflective sheeting to highlight barrier terminals.
- Locate the left barrier end to provide good visibility for left-turning traffic for both the barrier terminal and the on-ramp roadway.
- Extend the right barrier as far as feasible while providing a 4-foot clearance for the left-turning exiting design vehicle.
- Provide redundant signing.
- Provide enlarged warning signs.

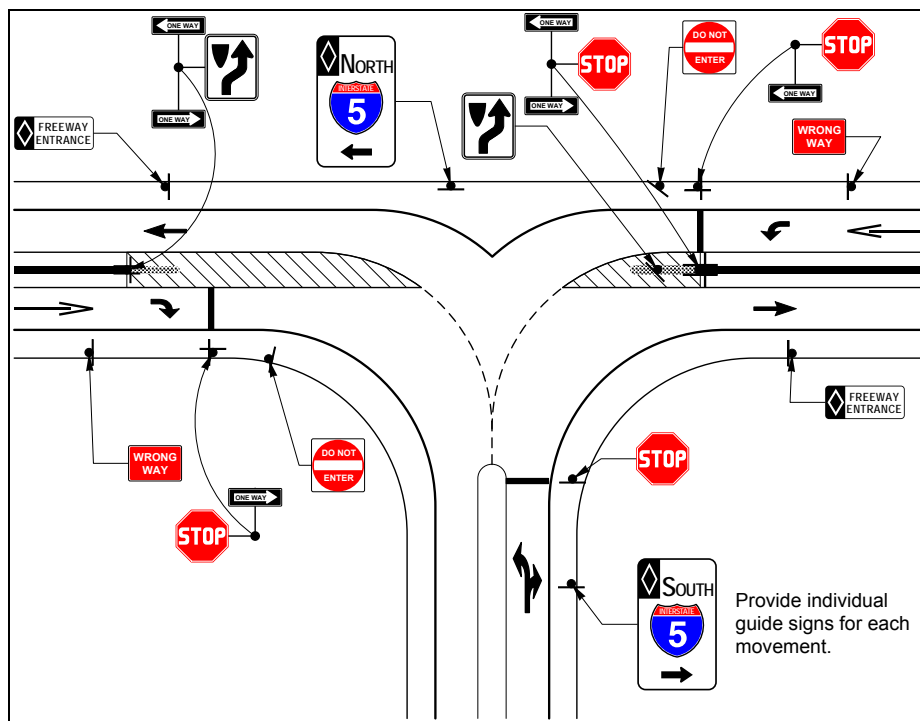
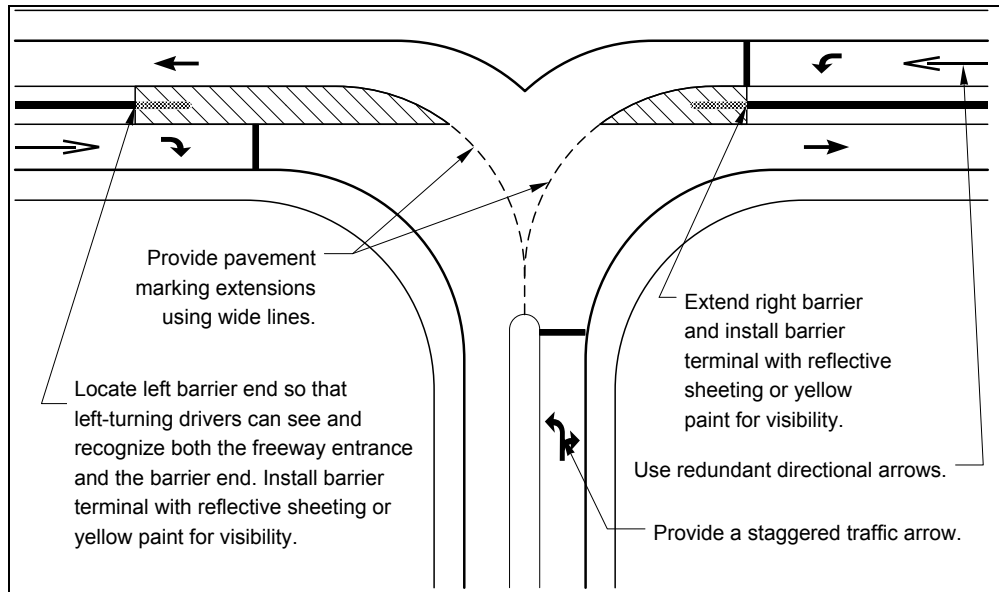

### 1420.06 Passenger Access

When designing transit stops, include accessibility (compliance with the ADA), safety, and the comfort of passengers. Minimize pedestrian/vehicle conflict points. Design the whole facility with security in mind by keeping lines of sight as open as possible. Traffic barriers, fencing, illumination, landscaping, seating, windscreens, shelters, enclosed walkways, telephones, and posted schedules are examples of items that contribute to passenger safety and well-being. (See [Chapter 1430](#) for passenger amenities at transit stops.)

### 1420.06(1) **Passengers**

To encourage use of the passenger access facility for an express transit stop, provide a route that is the shortest distance to travel from the park & ride lot or local transit stop. Failure to do so might generate the use of undesirable shortcuts. To encourage local use of the passenger access facilities, provide direct access from surrounding neighborhoods.

Provide grade separations for pedestrian access to transit stops in the median. Consider stairways, ramps, elevators, and escalators, but provide at least one access for the disabled at every loading platform, as required by the American with Disabilities Act of 1990. (See [Chapter 1510](#) for guidance when designing pedestrian grade separations.)

The *ADA Accessibility Guidelines for Buildings and Facilities* states, “Platform edges bordering a drop-off and not protected by platform screens or guard rails shall have a detectable warning . . . 24 inches wide running the full length of the platform drop-off.” (See the *Standard Plans* for the detectable warning pattern.)

At transit stops, at-grade crosswalks are only permitted in the at-grade crossing flyer stop layout described in [1420.04\(4\)\(a\)2](#). Use traffic calming techniques, such as horizontal alignment, textured pavement and crosswalk markings, barrier openings, and other treatments, to channelize pedestrian movements and slow the transit vehicle’s movements. Illuminate transit stop crosswalks (see [Chapter 1040](#)).

Where at-grade crosswalks are not permitted, take steps to minimize unauthorized at-grade crossings. Fencing, taller concrete traffic barrier, enclosed walkways, and ramps are examples of steps that may be taken.

### 1420.06(2) **Bicycles**

Bike lanes on nearby streets and separate trails encourage people to bicycle from surrounding neighborhoods. Provide these bicyclists direct access to passenger access facilities.

Design bicycle access facilities in conjunction with the access for the disabled (see [Chapters 1510, 1515, and 1520](#)).

Locate bicycle parking outside of the passenger walkways (see [Chapter 1430](#)).

Locations near colleges and universities and locations with good bicycle access, especially near trails, will attract bicyclists. Contact the region Bicycle Coordinator for information on the predicted number of bicycle parking spaces needed and the types of bicycle racks available.

## 1420.07 **Traffic Design Elements**

Traffic design elements are critical to the safe and efficient use of HOV direct access facilities. The following discusses the elements of traffic design that might be different for HOV direct access facilities.

### 1420.07(1) **Traffic Barriers**

Separate the main line from the HOV direct access facilities with a traffic barrier. Whenever possible, separate opposing traffic lanes in the facility by using traffic barrier (see [Chapter 1610](#)). This is especially important in areas where opposing traffic is changing speeds to or from main line speeds. Concrete barrier is generally desirable on these facilities due to lower maintenance requirements.



Provide crashworthy end treatments to the approach ends of traffic barriers. In areas where the operating speed is greater than 35 mph, provide an impact attenuator (see [Chapter 1620](#)). Consider concrete barrier and low-maintenance impact attenuators, such as the REACT 350 or QuadGuard Elite, where there is a potential for frequent impacts (such as in gore areas).

When the operating speed is 25 mph or lower, and where an at-grade pedestrian crossing transit stop has an opening in a concrete barrier, a sloped-down end as shown in the [Standard Plans](#) is acceptable.

When providing a break in the barrier for turning maneuvers, consider sight distance when determining the location for stopping the barrier (see [Chapter 1260](#)).

In areas where headlight glare is a concern, consider glare screens such as taller concrete barrier. Other glare screen options that mount on the top of a barrier tend to be high-maintenance items and are discouraged.

Taller barrier might also be desirable in areas where pedestrian access is discouraged, such as between opposing flyer stops or between a flyer stop and the main line.

### 1420.07(2) **Signing**

Design and place HOV signing to clearly indicate whether the signs are intended for motorists in the HOV lane or the general-purpose lanes. The purposes of the signs are to:

- Enhance safety.
- Convey the message that HOV lanes are restricted to HOVs.
- Provide clear directions for entrances and exits.
- Define vehicle occupancy requirements or other restrictions.

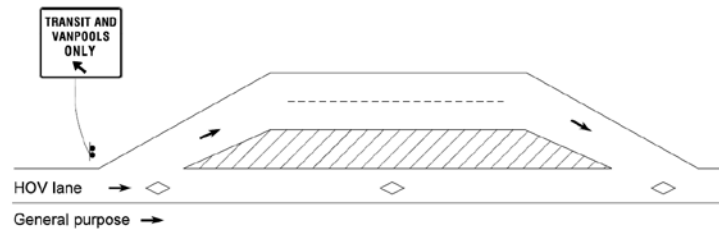

Typical Signing for Flyer Stop

Because HOV facilities are not found in many regions, the signing not only considers the commuter but also the occasional user of the facility who might be unfamiliar with the HOV facility and its operation.

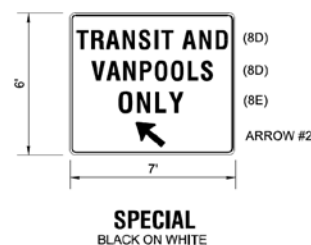

Special Flyer Stop Sign

### 1420.07(2)(a) **Safety**

Much of HOV signing relates to enhancing safety for motorists. Not only are geometrics often minimized due to the lack of right of way, but there are unusual operational characteristics such as the differential speed between the HOV vehicle and the adjacent general-purpose traffic. To allow for the lack of passing opportunities in the HOV lane and the necessity for frequent merging and weaving actions, use messages that are clear and concise, and use symbols wherever possible.

Because left-side off-connections are unusual, advance warning signing alerting motorists that an exit is on the left becomes more important.

For T ramps, provide traffic control at the T to assign priority to one of the turn movements and to avert wrong-way movements.

### 1420.07(2)(b) Diamond Symbols

The diamond symbol is used to designate HOV facilities where carpools are allowed. For all signs, whether regulatory, guide, or warning, the symbol is white on a black background to convey the restrictive nature of the HOV lane and to make the signs more uniformly recognizable. The use of the symbol with all HOV signs also informs drivers that the message is intended for HOVs. The diamond symbol is only for HOV lanes where carpools are allowed; it is not used for bus, taxi, or bicycle preferential lanes.

### 1420.07(2)(c) Selection and Location

The signing details given throughout this section provide for the HOV geometric configurations used within the right of way. Signing for other types of HOV facilities (such as those used for reversible-flow and for HOV direct access between freeways and temporary HOV lanes used during construction) is designed on a case-by-case basis and requires consultation with the appropriate Headquarters and region traffic personnel. In addition to the normal regulatory signs, include HOV guide signs, both advance and action, in the design of signing for HOV direct access between freeways.

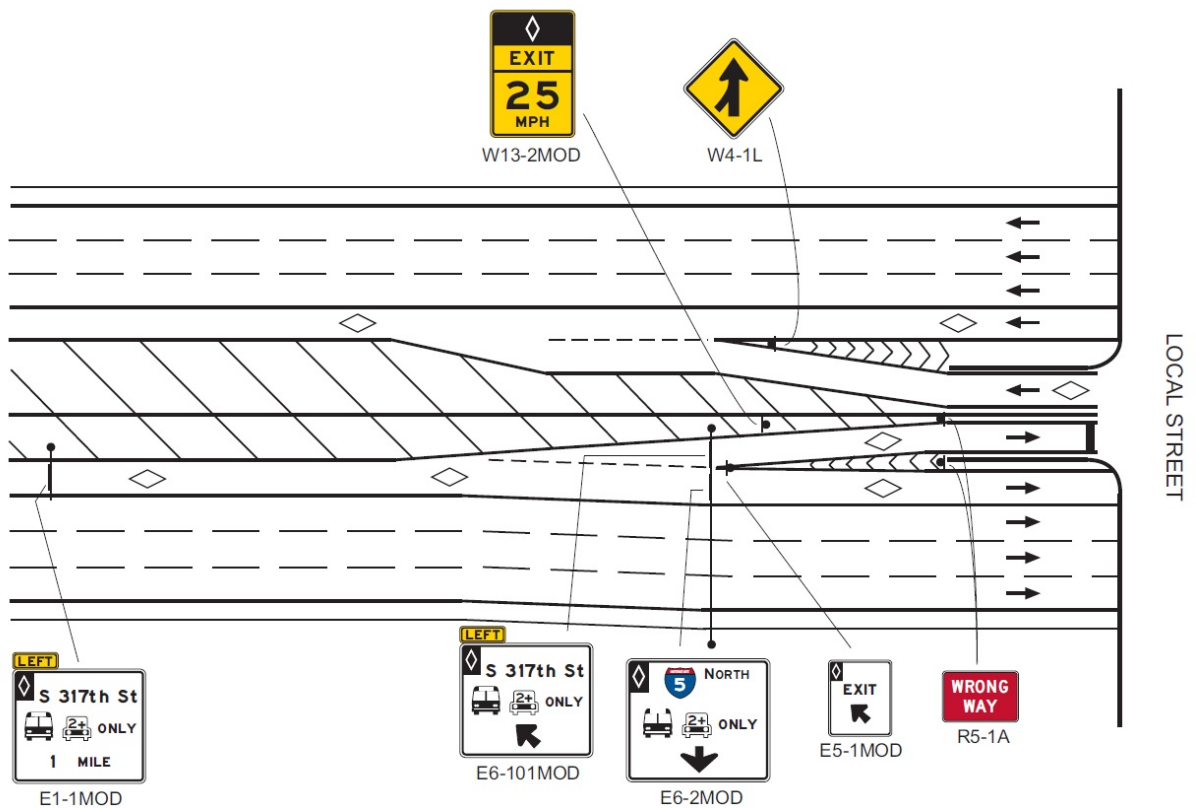

**Notes:**

- Place signs in accordance with the [MUTCD](#).
- For non-HOV sign details, see the [Sign Fabrication Manual](#).

1420.07(2)(d) Regulatory Signs

Regulatory signs for HOV facilities follow the normal regulatory signing principles: black legend with a white reflective background on a rectangular panel. Keep in mind that messages conveyed by the HOV signs (such as signs concerning violations and those indicating the beginning of an HOV lane downstream) are not necessarily intended only for the HOV vehicle. Therefore, it might be prudent to place additional signs on the right side of the freeway when doing so conforms to sound engineering practice.

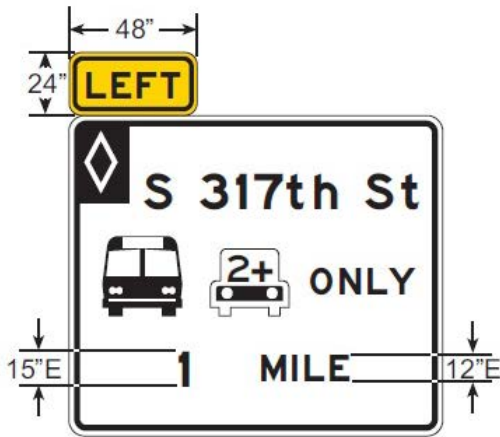

**E1-1 MOD.**  
BLACK ON WHITE

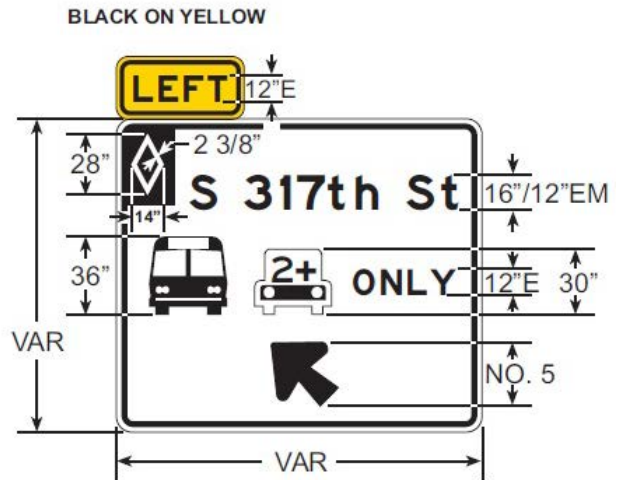

**E6-101 MOD.**  
BLACK ON WHITE

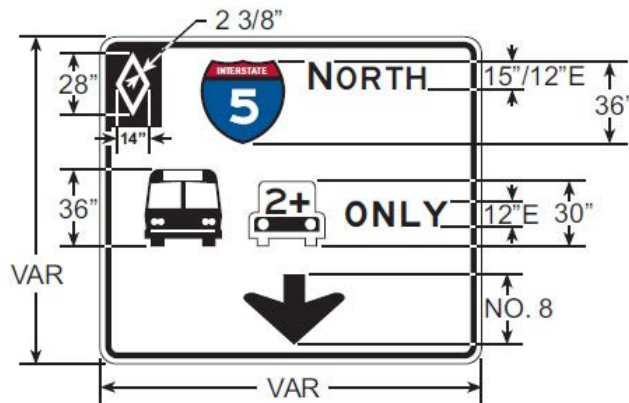

**E6-2 MOD.**  
BLACK ON WHITE

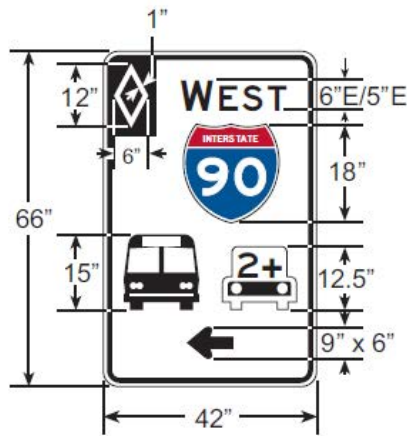

**D1-701 MOD.**  
 BLACK ON WHITE  
 SHIELD  
 LEGEND - WHITE (REFL)  
 TOP - RED (REFL)  
 BOTTOM - BLUE (REFL)

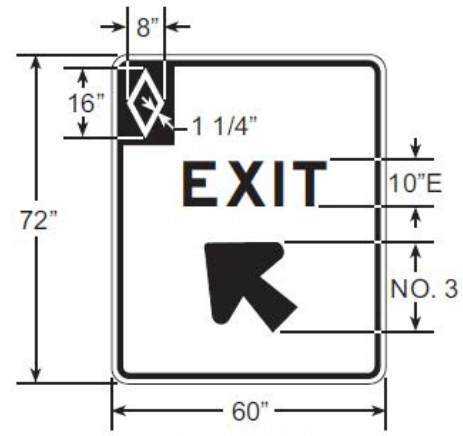

**E5-1 MOD.**  
 BLACK ON WHITE

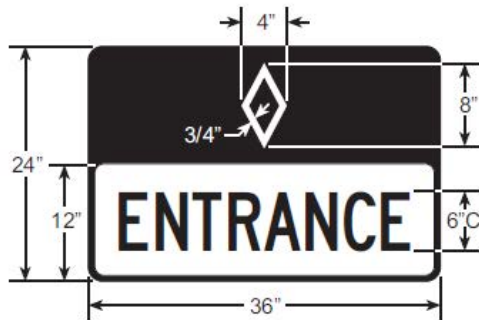

**E12-201 MOD.**  
 BLACK ON WHITE

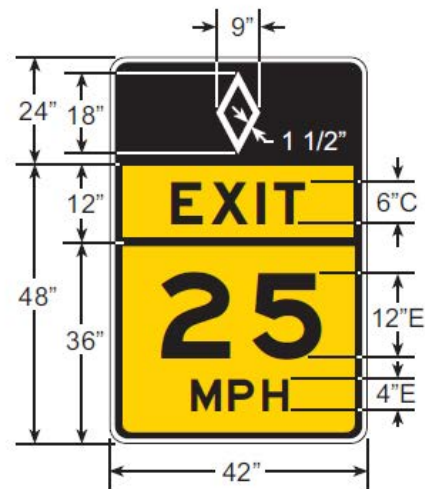

**W13-2 MOD.**  
 WHITE ON BLACK &  
 BLACK ON YELLOW



Guide striping provided for left-hand turns.



Do Not Enter sign located on the left side at the top of each off-ramp.



Keep Right sign located at the top of the median barrier separating on- and off-ramps.



HOV Entrance sign located on the right side at the beginning of each on-ramp.



Wrong Way signs (30° rotation at potential wrong-way entrance point).



Diamonds and Turn Only pavement markings on off-ramps.

1420.07(2)(e) Guide Signs

Guide signs for HOV facilities are generally used at intermediate on and off locations to inform HOV motorists of upcoming freeway exits and the appropriate location to exit the HOV lane. For HOV direct access to and from arterials, guide signs are used in a fashion similar to normal arterial interchange signing practice. The guide signs for HOV facilities have a black nonreflective legend on a white reflective background. The exception is the diamond, where the white reflective symbol is on a black nonreflective background. For all HOV-related guide signs, the diamond is placed in the upper left-hand corner of the sign.

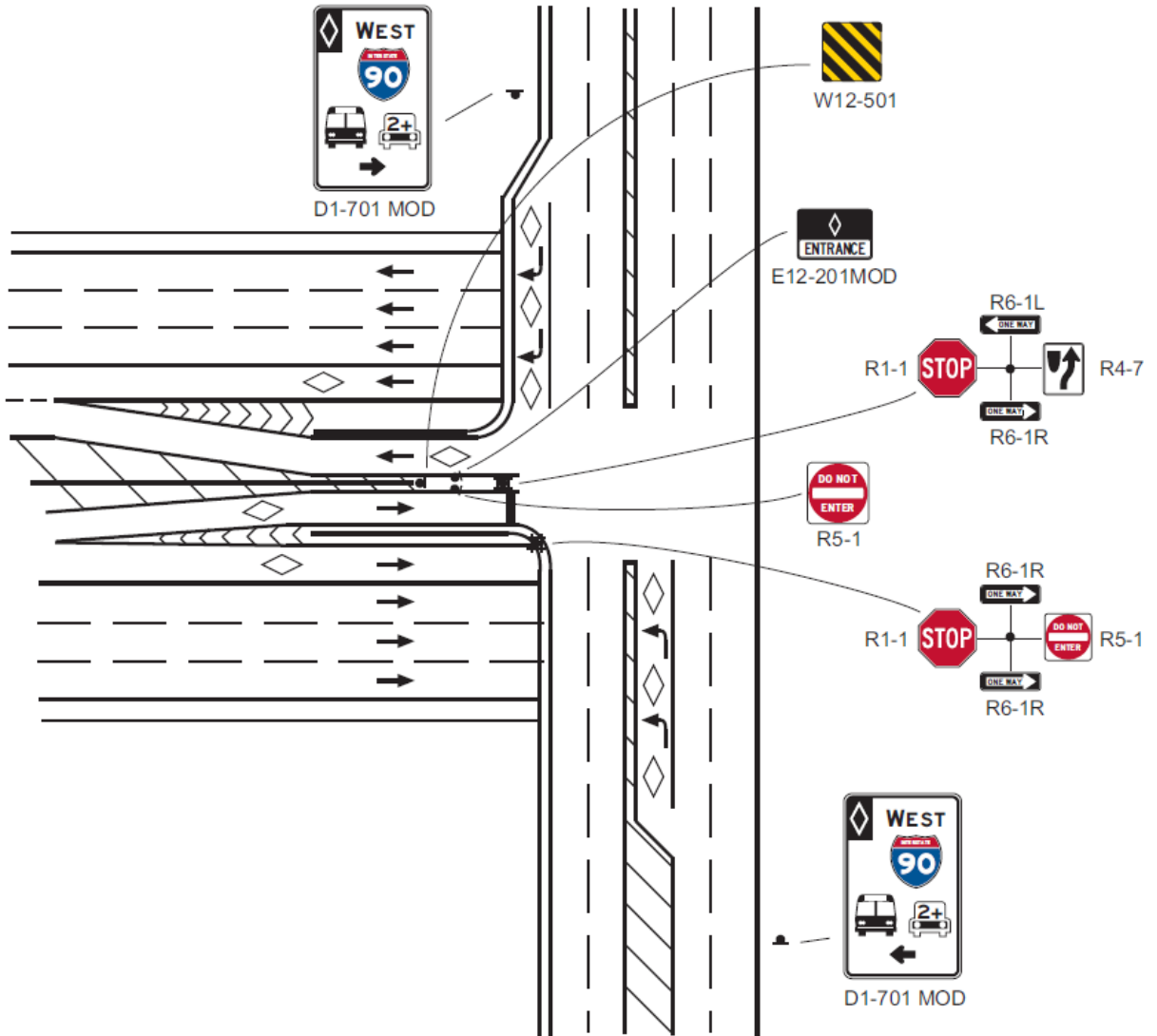

Notes:

- Sign placement shall be in accordance with the [MUTCD](#).
- For non-HOV sign details, see the [Sign Fabrication Manual](#).

**1420.07(3) Lighting**

Provide illumination of HOV direct access ramps, loading platforms at transit stops, major parking lots, and walkways as defined in [Chapter 1040](#).

**1420.07(4) Intelligent Transportation Systems**

Intelligent Transportation Systems (ITS) are used to collect traffic data, maintain freeway flow, and disseminate traveler information. Transit information systems for passengers and transit facility surveillance are not normally a part of WSDOT's system, but implementation of these components may be considered for some locations.

Fully utilize available ITS elements in the design of HOV direct access facilities. Need for ITS elements varies depending on project features, such as facility design and operation, and whether the site has existing ITS components.

ITS elements that might be applicable to HOV direct access facilities include: closed circuit television surveillance; ramp metering; data collection; exit queue detection and override; dynamic signing; transit signal priority; and automatic vehicle identification and location.

Guidance on the development of ITS elements is found in [Chapter 1050](#). Include the region Traffic Office, transit operator, and affected local agency in the coordination for the design and implementation of ITS.

**1420.08 Documentation**

Refer to [Chapter 300](#) for design documentation requirements.





- Stormwater outfall
- Available utilities
- Existing right of way or sundry site
- Potential for future expansion

Purchasing or leasing property increases costs substantially. Therefore, the first choice is state-owned right of way, assuming the other selection criteria are favorable. Also give prime consideration to the use of city- or county-owned right of way. Select a site that does not jeopardize the current and future integrity of the highway.

Investigate each potential site in the field. The field survey serves to confirm or revise impressions gained from the office review. When conducting the investigation, consider the following:

- Physical characteristics of the site.
- Current use and zoning of the area.
- Whether the site is visible from adjacent streets (to enhance security).
- Potential for additional expansion.
- Accessibility for motorists and other modes of travel, including transit.
- Proximity of any existing parking facilities (such as church or shopping center parking lots) that are underutilized during the day.
- Potential for joint use of facilities with businesses (such as day care centers or dry cleaners) or land uses compatible with park & ride patrons.
- Congestion and other design considerations.
- Avoid locations that encourage noncommuter use (such as proximity to a high school).

The desirable location for park & ride lots along one-way couplets is between the two one-way streets, with access from both streets. When this is not practicable, provide additional signing to guide users to and from the facility.

Establish potential sites, with transit agency input, and complete public meetings and environmental procedures prior to finalizing the design. Follow the procedures outlined in [Chapter 210](#).

## **(2) Design**

Design features to be in compliance with any local requirements that may apply. In some cases, variances to local design requirements may be needed to provide for the safety and security of facility users.

Include the following design components when applicable:

- Geometric design of access points.
- Efficient traffic flows, both internal and external circulation, for transit, carpools, vanpools, pedestrians, and bicycles.
- Parking space layout.
- Pavements.
- Shelters.
- Exclusive HOV facilities.
- Bicycle facilities.

- Motorcycle facilities.
- Traffic control devices, including signs, signals, and permanent markings.
- Illumination.
- Drainage and erosion control.
- Security of facility users and vehicles.
- Environmental mitigation.
- Landscape preservation and development.
- Restroom facilities.
- Telephone booths.
- Trash receptacles.
- Traffic data.
- Facilities that accommodate elderly and disabled users and meet barrier-free design requirements.

The degree to which the desirable attributes of any component are sacrificed to obtain the benefits of another component can only be determined on a site-specific basis. However, these guidelines present the optimum design elements of each factor.

Large park & ride lots are transfer points from private automobiles to transit buses. The same basic principles are used in designing all park & ride lots.

**(a) Access**

Six basic transportation modes are used to arrive at and depart from park & ride lots: walking, bicycle, motorcycle, private automobile (including carpools), vanpool, and bus. Provide for all these modes.

It is desirable that access to a park & ride lot not increase congestion on the facility it serves. The desirable access point to a park & ride lot is on an intersecting collector or local street. Locate entrances and exits with regard to adjacent intersections, so that signal control at these intersections can be reasonably installed at a later time. Provide storage for vehicles entering the lot and for exiting vehicles. Ease of access will encourage use of the facility.

When access is provided to an arterial, carefully consider the location and locate the access to avoid queues from nearby intersections.

The minimum width of entrances and exits used by buses is 15 feet per lane. (See [1430.09](#) for corner radii for buses and [Chapter 1340](#) and the *Standard Plans* for design of other access points.)

Design entrances and exits to conform to [Chapter 1340](#) or other published design guidelines used by the local agency.

Design the access route for transit to a park & ride lot, the circulation patterns within the lot, and the return route to minimize transit travel time. Exclusive direct access connections for buses, vanpools, and carpools between park & ride lots and freeway or street HOV lanes may be justified by time savings to riders and reduced transit costs. (See [Chapter 1420](#) for information on direct access design.) Coordinate routing for transit with the transit authority.

1510.01	General	1510.10	Crosswalks
1510.02	References	1510.11	Raised Medians/Traffic Islands
1510.03	Definitions	1510.12	Pedestrian Pushbuttons at Signals
1510.04	Policy	1510.13	At-Grade Railroad Crossings
1510.05	ADA Requirements by Project Type	1510.14	Pedestrian Grade Separations (Structures)
1510.06	Pedestrian Circulation Paths	1510.15	Other Pedestrian Facilities
1510.07	Pedestrian Access Routes (PARs)	1510.16	Illumination and Signing
1510.08	Sidewalks	1510.17	Work Zone Pedestrian Accommodation
1510.09	Curb Ramps	1510.18	Documentation

## 1510.01 General

Pedestrian travel is a vital transportation mode. It is used at some point by nearly everyone and is a critical link to everyday life for many. Designers must be aware of the various physical needs and abilities of pedestrians in order to ensure facilities provide universal access.

Section 504 of the Rehabilitation Act and the Americans with Disabilities Act of 1990 (ADA) require pedestrian facilities to be designed and constructed so they are readily accessible to and usable by persons with disabilities. This chapter provides accessibility criteria for the design of pedestrian facilities that meet applicable state and federal standards.

The pedestrian facilities included in a project are determined during the planning phase based on: access control of the highway; local transportation plans; comprehensive plans and other plans (such as Walk Route Plans developed by schools and school districts); the roadside environment; pedestrian volumes; user age group(s); and the continuity of local walkways along or across the roadway.

When developing pedestrian facilities within a limited amount of right of way, designers can be faced with multiple challenges. It is important that designers become familiar with the ADA accessibility criteria in order to appropriately balance intersection design with the often competing needs of pedestrians and other roadway users.

Similar to the roadway infrastructure, pedestrian facilities (and elements) require periodic maintenance in order to prolong the life of the facility and provide continued usability. Title II of the ADA requires that all necessary features be accessible and maintained in operable working condition for use by individuals with disabilities.

## 1510.02 References

### 1510.02(1) Federal/State Laws and Codes

[ADA](#) – 28 Code of Federal Regulations (CFR) Part 35, as revised September 15, 2010

[23 CFR Part 652](#), Pedestrians and Bicycle Accommodations and Projects

[49 CFR Part 27](#), Nondiscrimination on the Basis of Disability in Programs or Activities Receiving Federal Financial Assistance (Section 504 of the Rehabilitation Act of 1973 implementing regulations)

[Revised Code of Washington \(RCW\) 35.68](#), Sidewalks, gutters, curbs and driveways – All cities and towns

[RCW 35.68.075](#), Curb ramps for persons with disabilities – Required – Standards and Requirements

[RCW 46.04.160](#), Crosswalk (definition)

[RCW 46.61](#), Rules of the Road

[RCW 47.24.020](#), City streets as part of state highways – Jurisdiction, control

### **1510.02(2) Design Guidance**

*Manual on Uniform Traffic Control Devices for Streets and Highways*, USDOT, FHWA; as adopted and modified by [Chapter 468-95 WAC](#) “Manual on uniform traffic control devices for streets and highways” (MUTCD)

☞ [www.wsdot.wa.gov/publications/manuals/mutcd.htm](http://www.wsdot.wa.gov/publications/manuals/mutcd.htm)

*Revised Draft Guidelines for Accessible Public Rights-of-Way (PROWAG)*, November 23, 2005, U.S. Access Board. The current best practices for evaluation and design of pedestrian facilities in the public right of way per the following FHWA Memoranda:

☞ <http://www.fhwa.dot.gov/environment/bikeped/prwaa.htm>

☞ [http://www.fhwa.dot.gov/civilrights/memos/ada\\_memo\\_clarificationa.htm](http://www.fhwa.dot.gov/civilrights/memos/ada_memo_clarificationa.htm)

☞ [www.access-board.gov/prowac/draft.htm](http://www.access-board.gov/prowac/draft.htm)

*Standard Plans for Road, Bridge, and Municipal Construction (Standard Plans)*, M 21-01, WSDOT

☞ [www.wsdot.wa.gov/publications/manuals/m21-01.htm](http://www.wsdot.wa.gov/publications/manuals/m21-01.htm)

*ADA Standards for Accessible Design*, U.S. Department of Justice (USDOJ), 2010; consists of 28 CFR parts 35 & 36 and the *ADA and Architectural Barriers Act (ABA) Accessibility Guidelines for Buildings and Facilities (ADA-ABAAG)*; also referred to as the 2004 ADAAG), July 23, 2004, U.S. Access Board. (For buildings and on-site facilities; applies to new construction or alterations as of March 15, 2012.)

☞ [www.access-board.gov/ada/](http://www.access-board.gov/ada/)

*ADA Standards for Transportation Facilities*, USDOT, 2006; consists of 49 CFR Parts 37 & 38 and the *ADA and ABA Accessibility Guidelines for Buildings and Facilities (ADA-ABAAG)*; also referred to as the 2004 ADAAG), July 23, 2004, U.S. Access Board as modified by USDOT. (For transit, light rail, and similar public transportation facilities.)

☞ [www.access-board.gov/ada/](http://www.access-board.gov/ada/)

### **1510.02(3) Supporting Information**

*1991 ADA Standards for Accessible Design*, USDOJ; consists of 28 CFR parts 35 & 36 and the *ADA Accessibility Guidelines for Buildings and Facilities (ADAAG)*, July 1991, U.S. Access Board. (For buildings and on-site facilities: Expired for new construction and alterations. To be used only for evaluating the adequacy of new construction or alteration that occurred prior to March 15, 2012.)

☞ [www.access-board.gov/ada/](http://www.access-board.gov/ada/)

*A Policy on Geometric Design of Highways and Streets (Green Book)*, AASHTO, Current version adopted by FHWA

*Field Guide for Accessible Public Rights of Way*, WSDOT, November 1, 2012

☞ [http://www.wsdot.wa.gov/publications/fulltext/roadside/ada\\_field\\_guide.pdf](http://www.wsdot.wa.gov/publications/fulltext/roadside/ada_field_guide.pdf)

*Guide for the Planning, Design, and Operation of Pedestrian Facilities*, AASHTO, 2004. Provides guidance on the planning, design, and operation of pedestrian facilities along streets and highways. Specifically, the guide focuses on identifying effective measures for accommodating pedestrians on public rights of way. It can be purchased through the AASHTO website.

*Highway Capacity Manual*, Transportation Research Board (TRB), 2000

*Pedestrian Facilities Guidebook: Incorporating Pedestrians Into Washington's Transportation System*, OTAK, 1997

☞ [www.wsdot.wa.gov/publications/manuals/fulltext/m0000/pedfacgb.pdf](http://www.wsdot.wa.gov/publications/manuals/fulltext/m0000/pedfacgb.pdf)

*Pedestrian Facilities Users Guide – Providing Safety and Mobility*, FHWA, 2002. Provides useful information regarding walkable environments, pedestrian crashes and their countermeasures, and engineering improvements for pedestrians.

☞ [http://drusilla.hsrc.unc.edu/cms/downloads/pedfacility\\_userguide2002.pdf](http://drusilla.hsrc.unc.edu/cms/downloads/pedfacility_userguide2002.pdf)

*Proposed Accessibility Guidelines for Pedestrian Facilities in the Public Right-of-Way*, July 26, 2011, U.S. Access Board. Federal Notice of Proposed Rule Making that gives a preview of potential future revisions to the PROWAG.

☞ [www.access-board.gov/prowac/nprm.htm](http://www.access-board.gov/prowac/nprm.htm)

“Special Report: Accessible Public Rights-of-Way – Planning & Design for Alterations,” Public Rights-of-Way Access Advisory Committee, July 2007

☞ [www.access-board.gov/prowac/alterations/guide.htm](http://www.access-board.gov/prowac/alterations/guide.htm)

*Understanding Flexibility in Transportation Design – Washington*, WSDOT, 2005

☞ [www.wsdot.wa.gov/research/reports/600/638.1.htm](http://www.wsdot.wa.gov/research/reports/600/638.1.htm)

Washington State Bicycle Facilities and Pedestrian Walkways Plan

☞ [www.wsdot.wa.gov/bike/bike\\_plan.htm](http://www.wsdot.wa.gov/bike/bike_plan.htm)

*Terminal Design Manual*, Chapter 300 Accessibility, WSDOT, Washington State Ferries Division

☞ [www.wsdot.wa.gov/publications/manuals/m3082.htm](http://www.wsdot.wa.gov/publications/manuals/m3082.htm)

### 1510.03 Definitions

Refer to the “ADA / Pedestrian Terms” section of the *Design Manual Glossary* for definitions of many of the terms used in this chapter.

### 1510.04 Policy

#### 1510.04(1) General

It is WSDOT policy to provide appropriate pedestrian facilities along and across sections of state routes as an integral part of the transportation system. Federal Highway Administration (FHWA) and WSDOT policy is that bicycle and pedestrian facilities be given full consideration in the planning and design of new construction and reconstruction highway projects, except where bicycle and pedestrian use is prohibited.

### **1510.04(2) Jurisdiction**

Proposed projects in public rights of way must address ADA compliance as described in this chapter. (See [1510.05](#) for ADA requirements by project type.) Regardless of which public agency has jurisdiction within the right of way, the public agency that is sponsoring the project is responsible for ensuring ADA compliance is addressed on its project.

On all state routes outside of incorporated cities and on those with limited access (full, partial, and modified) within incorporated cities, jurisdiction remains with the state unless modified by a maintenance agreement. In turnback areas where the turnback agreement has not been completed, the state maintains full jurisdiction (see Chapters [510](#), [520](#), and [530](#)).

When project work occurs on a managed access state route inside an incorporated city that has jurisdiction beyond the curbs ([RCW 47.24.020](#)), design pedestrian facilities using the city design standards adopted in accordance with [RCW 35.78.030](#) and the most current ADA requirements. Document the coordination with the city in the Design Documentation Package (DDP). Refer to [Chapter 300](#) for information about the DDP.

### **1510.04(3) Transition Planning**

Section 504 of the Rehabilitation Act and the ADA require all public entities to conduct a self-evaluation of their programs and activities, including sidewalks, curb ramps, and other pedestrian facilities and elements within the public right of way, to determine if barriers exist that prevent people with disabilities from being able to access these programs and activities.

If barriers are identified, agencies with 50 or more employees must develop and implement a transition plan that describes the barriers, the modifications needed, and a schedule for when the needed work will be accomplished.

### **1510.04(4) Maintenance**

As noted in [1510.01](#), Title II of the ADA requires that a public entity maintain in operable working condition those features of facilities and equipment that are required to be readily accessible to and usable by persons with disabilities.

## **1510.05 ADA Requirements by Project Type**

Wherever pedestrian facilities are intended to be a part of the transportation facility, federal regulations ([28 CFR Part 35](#)) require that those pedestrian facilities meet ADA guidelines. All new construction or alteration of existing transportation facilities must be designed and constructed to be accessible to and usable by persons with disabilities. FHWA is one of the federal agencies designated by the Department of Justice to ensure compliance with the ADA for transportation projects.

### **1510.05(1) New Construction Projects**

New construction projects address the construction of a new roadway, interchange, or other transportation facility where none existed before. For these projects, pedestrians' needs are assessed and included in the project. All pedestrian facilities included in these projects must fully meet the accessibility criteria when built.

### 1510.05(2) Alteration Projects

Any project that affects or could affect the usability of a pedestrian facility is classified as an alteration project. Alteration projects include, but are not limited to, renovation; rehabilitation; reconstruction; historic restoration; resurfacing of circulation paths or vehicular ways; and changes or rearrangement of structural parts or elements of a facility. Where existing elements or spaces are altered, each altered element or space within the limits of the project shall comply with the applicable accessibility requirements to the maximum extent feasible.

The following are some examples of project types that are classified as alteration projects and can potentially trigger a variety of ADA requirements:

- HMA overlay or inlay
- Traffic signal installation or retrofit
- Roadway widening
- Realignment of a roadway (vertical or horizontal)
- Sidewalk improvements
- PCCP panel repair/replacement
- Bridge replacement
- Raised channelization

The following are not considered alterations:

- Spot pavement repair
- Liquid-asphalt sealing, chip seal (BST), or crack sealing
- Lane restriping that does not alter the usability of the shoulder

If there is uncertainty as to whether a project meets the definition of an alteration project, consult with the Regional ADA Coordinator.

The following apply to alteration projects:

- All new pedestrian facilities included in an alteration project that are put in place within an existing developed right of way must meet applicable accessibility requirements to the maximum extent feasible.
- All existing pedestrian facilities disturbed by construction of an alteration project must be replaced. The replacement facilities must meet applicable accessibility requirements to the maximum extent feasible.
- An alteration project shall not decrease or have the effect of decreasing the accessibility of a pedestrian facility or an accessible connection to an adjacent building or site below the ADA accessibility requirements in effect at the time of the alteration.
- Within the construction impact zone of an alteration project, any existing connection from a pedestrian access route to a crosswalk (marked or unmarked) that is missing a required curb ramp must have a curb ramp installed that meets applicable accessibility requirements to the maximum extent feasible. (See [1510.09\(2\)](#) for curb ramp accessibility criteria.)
- A crosswalk served by a curb ramp must also have an existing curb ramp in place on the receiving end unless there is no curb or sidewalk on that end of the crosswalk ([RCW 35.68.075](#)). If there is no existing curb ramp in place on the receiving end, an accessible curb ramp must be provided. This requirement must be met regardless of whether the receiving end of the crosswalk is located within the project's limits.

- Within the construction impact zone of an alteration project, evaluate all existing curb ramps to determine whether curb ramp design elements meet the accessibility criteria. (See [1510.09\(2\)](#) for curb ramp accessibility criteria.) Modify existing curb ramps that do not meet the accessibility criteria to meet applicable accessibility requirements to the maximum extent feasible. This may also trigger modification of other adjacent pedestrian facilities to incorporate transitional segments in order to ensure specific elements of a curb ramp will meet the accessibility criteria.
- Within the construction impact zone of an alteration project that includes hot mix asphalt overlay (or inlay) of an existing roadway and *does not* include reconstruction, realignment, or widening of the roadway, evaluate all existing marked and unmarked crosswalks. (See [1510.10\(2\)](#) for crosswalk accessibility criteria.) If it is not possible to meet the applicable accessibility requirements for crosswalks, document this in the DDP.
- Within the construction impact zone of an alteration project that includes reconstruction, realignment, or widening of the roadway, evaluate all existing crosswalks (marked or unmarked) to determine whether crosswalk design elements meet the accessibility criteria. (See [1510.10\(2\)](#) for crosswalk accessibility criteria.) Modify crosswalk slopes to meet the applicable accessibility requirements to the maximum extent feasible.

It may not always be possible to fully meet the applicable accessibility requirements during alterations of existing facilities. If such a situation is encountered, consult with the Regional ADA Coordinator to develop a workable solution to meet the accessibility requirements to the maximum extent feasible. Cost is not to be used as a justification for not meeting the accessibility criteria. Physical terrain or site conditions that would require structural impacts, environmental impacts, or unacceptable impacts to the community in order to achieve full compliance with the accessibility criteria are some of the factors that can be used to determine that the maximum extent feasible is achieved. If it is determined to be virtually impossible to meet the accessibility criteria for an element, document the decision in one of the following ways, as applicable:

- Within the construction impact zone of an alteration project that does not include reconstruction, realignment, or widening of the roadway, document the following deficient elements in the DDP:
  - Perpendicular curb ramp or parallel curb ramp landing cross slope that is constrained by the existing roadway gutter profile and exceeds 2%, but is less than or equal to 5%, that cannot be constructed to fully meet applicable accessibility requirements.
  - Flared side of a perpendicular curb ramp that is constrained by the existing roadway gutter profile and has a slope that exceeds 10%, but is less than or equal to 16.7%, that cannot be constructed to fully meet applicable accessibility requirements.
- For any deficient element that does not match the preceding description, document the decision via a Maximum Extent Feasible (MEF) document. The MEF document will be reviewed by the appropriate Assistant State Design Engineer (ASDE) and the Headquarters (HQ) ADA Compliance Manager. If acceptable, the MEF document will be approved and included in the DDP.



## 1510.06 Pedestrian Circulation Paths

Pedestrian circulation paths are prepared exterior or interior ways of passage provided for pedestrian travel. They include independent walkways, sidewalks, shared-use paths, and other types of pedestrian facilities. Pedestrian circulation paths can either be immediately adjacent to streets and highways or separated from them by a buffer. Examples of pedestrian circulation paths are shown in [Exhibit 1510-1](#).

When the pedestrian circulation path is located behind guardrail, address protruding bolts. Installing a rub rail or a “W-beam” guardrail on the pedestrian side of the posts can mitigate potential snagging and also serve as a guide for sight-impaired pedestrians.

Provide a smooth finish to vertical surfaces adjacent to a pedestrian circulation path to mitigate potential snagging or abrasive injuries from accidental contact with the surface. Where adjacent walkway segments diverge, such as can occur if a parallel curb ramp does not occupy the entire width of a pedestrian circulation path, any resulting drop-offs must be protected to prevent trips or falls.

When relocation of utility poles and other fixtures is necessary for a project, determine the impact of their new location on all pedestrian circulation paths. Look for opportunities to relocate obstructions, such as existing utility objects, away from the pedestrian circulation path.

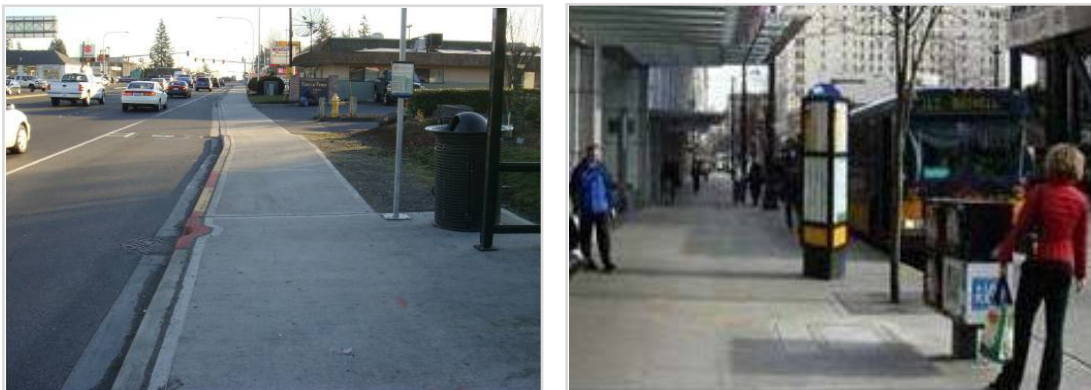

**Pedestrian Circulation Paths**

*Exhibit 1510-1*

Highway shoulders are an extension of the roadway and are not typically considered pedestrian facilities. Pedestrians are allowed to use many state highways. Although pedestrians are allowed to travel along the shoulder in these cases, its main purpose is to provide an area for disabled vehicles, a recovery area for errant vehicles, and positive drainage away from the roadway.

Shoulders may serve as a pedestrian facility when sidewalks are not provided. If pedestrian generators, such as bus stops, are present and pedestrian usage is evident, a 4-foot-wide paved shoulder is adequate. Note that detectable warning surfaces should not be installed where a sidewalk ends and pedestrians are routed onto a shoulder since the shoulder is not a vehicular traveled way.

Where pedestrian traffic is evident, consider a separate pedestrian circulation path during the planning and programming of the project. Consult with the State Bicycle and Pedestrian Coordinator.

### 1510.06(1) Accessibility Criteria for Pedestrian Circulation Paths

The following criteria apply across the entire width of the pedestrian circulation path, not just within the pedestrian access route.

#### 1510.06(1)(a) Vertical Clearance

- The minimum vertical clearance for objects that protrude into or overhang a pedestrian circulation path is 80 inches.
- If the minimum vertical clearance cannot be provided, railings or other barriers shall be provided. The leading bottom edge of the railing or barrier shall be located 27 inches maximum above the finished surface for cane detection.

*Note:* Per the [MUTCD](#), the vertical clearance to the bottom of signs is 7 feet (84 inches.)

#### 1510.06(1)(b) Horizontal Encroachment

- Protruding objects on pedestrian circulation paths shall not reduce the clear width of the pedestrian access route to less than 4 feet, exclusive of the curb.

*Note:* If an object must protrude farther than 4 inches into a pedestrian circulation path at a height that is greater than 27 inches and less than 80 inches above the finished surface, then it must be equipped with a warning device that is detectable by a vision-impaired person who navigates with a cane. The minimum clear width of the pedestrian access route must still be provided.

#### 1510.06(1)(c) Post-Mounted Objects

- Objects mounted on posts, at a height that is greater than 27 inches and less than 80 inches above the finished surface, shall not protrude more than 4 inches into a pedestrian circulation path.

*Note:* If an object must protrude farther than 4 inches into a pedestrian circulation path at a height that is greater than 27 inches and less than 80 inches above the finished surface, then it must be equipped with a warning device that is detectable by a vision-impaired person who navigates with a cane. The minimum clear width of the pedestrian access route must still be provided.

- Where a sign or other obstruction on a pedestrian circulation path is mounted on multiple posts, and the clear distance between the posts is greater than 12 inches, the lowest edge of the sign or obstruction shall be either 27 inches maximum or 80 inches minimum above the finished surface.

### 1510.07 Pedestrian Access Routes (PARs)

All pedestrian circulation paths (PCPs) are required to contain a continuous pedestrian access route (see [Exhibit 1510-2](#)) that connects to all adjacent pedestrian facilities, elements, and spaces that are required to be accessible. Pedestrian access routes consist of one or more of the following pedestrian facilities: walkways/sidewalks, crosswalks, curb ramps (excluding flares), landings, pedestrian overpasses/underpasses, access ramps, elevators, and platform lifts.

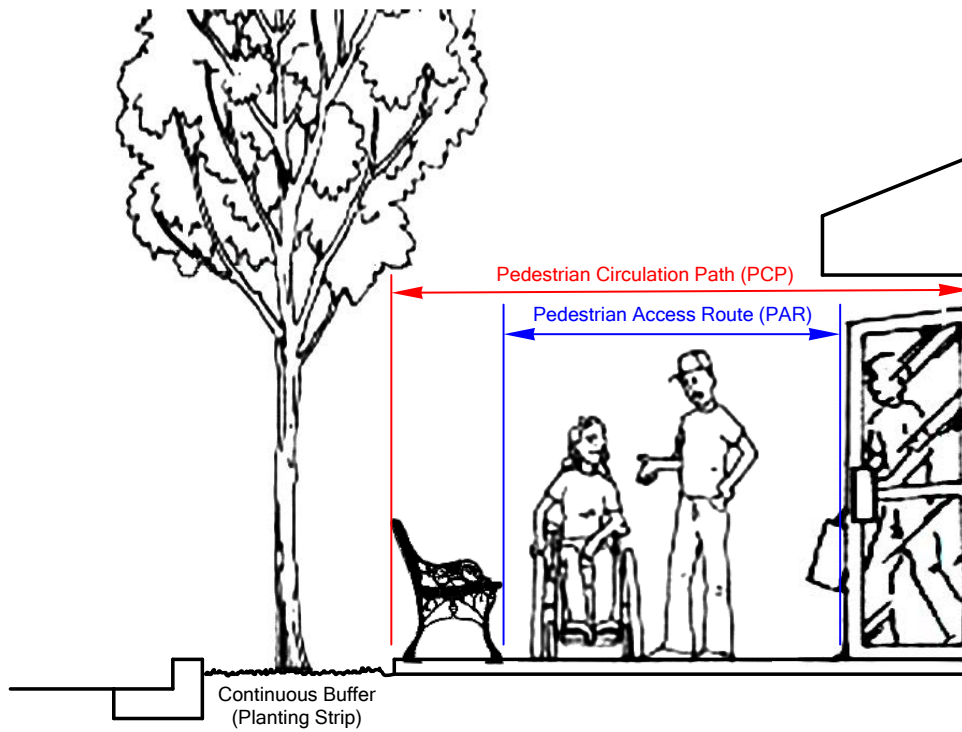

With Continuous Buffer

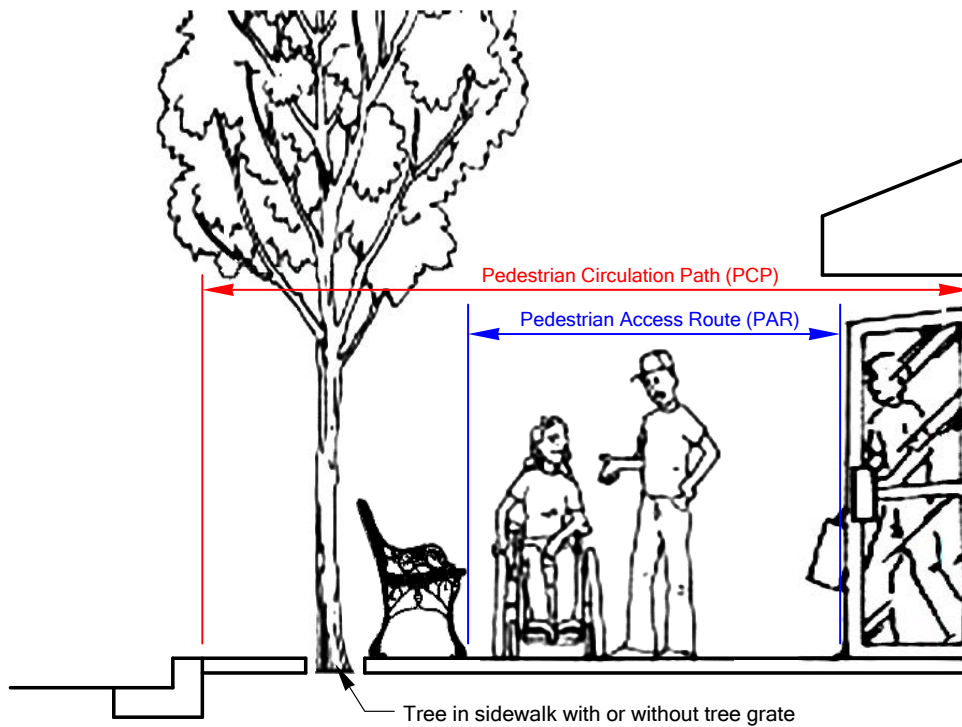

Without Continuous Buffer

**Relationship Between Pedestrian Circulation Paths and Pedestrian Access Routes**  
*Exhibit 1510-2*

### 1510.07(1) Accessibility Criteria for Pedestrian Access Routes

#### 1510.07(1)(a) Clear Width

- The minimum continuous and unobstructed clear width of a pedestrian access route shall be 4 feet, exclusive of the width of the curb.
- Pedestrian access routes that are less than 5 feet in clear width, exclusive of the width of the curb, shall provide passing spaces at intervals no farther apart than 200 feet. Passing spaces shall be 5 feet wide minimum, for a minimum distance of 5 feet.



**Note:** Provide wheel stops or a wider sidewalk to remedy the encroachment into the PAR.

#### Obstructed Pedestrian Access Route

*Exhibit 1510-3*

#### 1510.07(1)(b) Cross Slope and Grade

- The cross slope of a pedestrian access route shall be 2% maximum.

**Note:** It is recommended that cross slopes be designed to be less than the allowed maximum to allow for some tolerance in construction. For example: design for a maximum 1.5% cross slope (rather than 2% maximum).

**Exceptions:**

1. Midblock crosswalks – The cross slope of the crosswalk and any connected curb ramp is permitted to match street or highway grade.
  2. Crosswalks without stop sign control – The cross slope of the crosswalk can be up to 5% maximum.
- Where a pedestrian access route is contained within the highway right of way, its grade shall not exceed the general grade established for the adjacent roadway.

**Exception:** The maximum grade in a crosswalk (marked or unmarked) is 5%, measured parallel to the direction of pedestrian travel in the crosswalk.

- Where a pedestrian access route is not contained within the highway right of way, the maximum running slope allowed is 5% unless designed as an access ramp. (See [1510.15\(2\)](#) for access ramp accessibility criteria.)
- For additional criteria when a pedestrian access route is supported by a structure, see [1510.14](#).

**1510.07(1)(c) Surface**

- The surface of the pedestrian access route shall be firm, stable, and slip resistant. Use hard surfaces like cement or asphalt concrete; crushed gravel is not considered to be a stable, firm surface.
- Vertical alignment shall be planar within curb ramps, landings, and gutter areas within the pedestrian access route and within clear spaces for accessible pedestrian signals, street furniture, and operable parts.
- Grade breaks shall be flush.
- Surface discontinuities (see Exhibits 1510-4 and 1510-5) on existing surfaces in the pedestrian access route (such as at the joints of settled or upheaved sidewalk panels) may not exceed ½ inch maximum. Vertical discontinuities between ¼ inch and ½ inch maximum shall be beveled at 2H:1V or flatter. Apply the bevel across the entire level change.

**Exception:** No surface discontinuity is allowed at the connection between an existing curb ramp or landing and the gutter. This grade break must be flush.

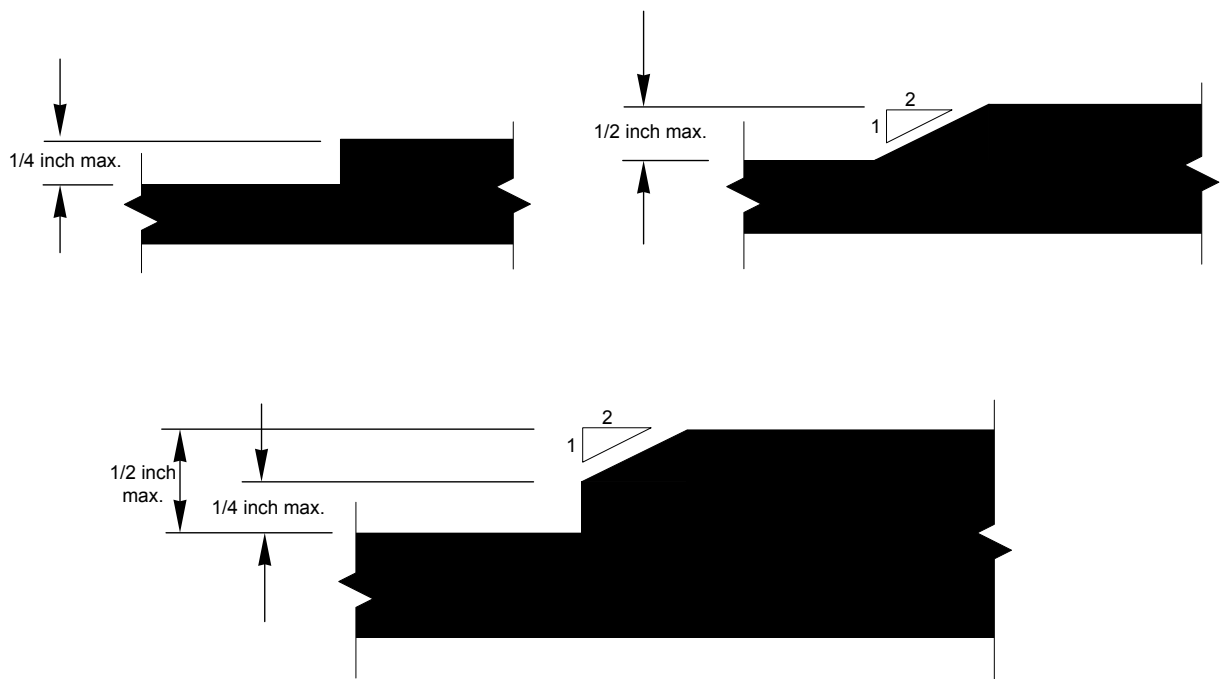

**Beveling Options**  
Exhibit 1510-4



### Surface Discontinuities (Noncompliant)

#### Exhibit 1510-5

- Gratings, access covers, utility objects, and other appurtenances shall not be located on curb ramps, landings, or gutters within the pedestrian access route.
- Locate gratings, access covers, utility objects, and other appurtenances outside the pedestrian access route on walkways and sidewalks. Where this is not possible, ensure covers, grates, and lids are designed to be slip resistant and are installed flush with the surrounding surface (see the *Standard Plans*).

#### 1510.07(1)(d) Horizontal Openings

- Any sidewalk joints or gratings that are in the pedestrian access route shall not permit passage of a sphere more than ½ inch in diameter.
- Elongated openings shall be placed so that the long dimension is perpendicular to the dominant direction of travel.
- Openings for wheel flanges at pedestrian crossings of nonfreight rail track shall be 2½ inches maximum (3 inches maximum for freight rail track).
- For additional requirements when a pedestrian access route crosses a railroad, see [1510.13](#).

### 1510.08 Sidewalks

Sidewalks are one type of pedestrian circulation path. (See [1510.06](#) for pedestrian circulation path accessibility criteria.) Plan the design of sidewalks carefully to include a pedestrian access route that provides universal access. (See [1510.07](#) for pedestrian access route accessibility criteria.) Sidewalk design elements are found in [Exhibit 1510-7](#) and details for raised sidewalks are shown in the *Standard Plans*. Wherever appropriate, make sidewalks continuous and provide access to side streets. The most pleasing and comfortable installation for the pedestrian is a sidewalk separated from the traveled way by a planted buffer. This provides a greater separation between vehicles and pedestrians than curb alone.

### 1510.08(1) Sidewalk and Buffer Widths

The WSDOT minimum sidewalk width is 5 feet (excluding the curb), but providing wider sidewalks is encouraged. Wider sidewalks are desirable on major arterials, in central business districts, and along parks, schools, and other major pedestrian generators. When sidewalks abut storefronts, additional width should be provided to accommodate window-shoppers and to avoid conflicts with opening doors and pedestrians entering or leaving the buildings.

When a buffer (vegetated as well as alternate pavement) is provided, the buffer should be at least 3 feet wide (excluding the curb). Document the decision to reduce a buffer width to less than 3 feet in the DDP.

If trees or shrubs are included in a buffer, coordinate with the region or HQ Landscape Architect. Take into account Design Clear Zone guidelines (see [Chapter 1600](#)). Design subsurface infrastructure (such as structural soils) and select plants whose root systems do not cause sidewalks to buckle or heave. Coordinate buffer planting with maintenance personnel.

Where possible, strive to accommodate snow storage while keeping the pedestrian route free of snow accumulation. Make sure maintenance access is not obstructed. Shoulders, bike lanes, and on-street parking are not considered buffers, but they do offer the advantage of further separation between vehicles and pedestrians.

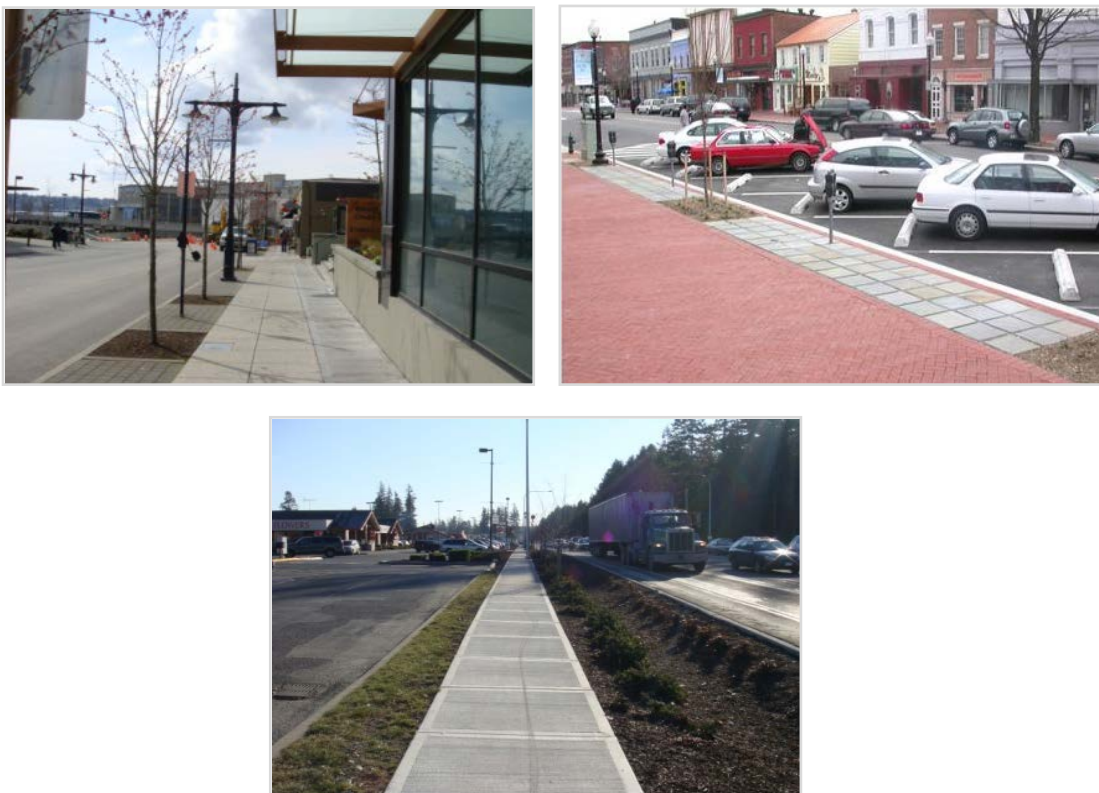

**Sidewalks With Buffers**

*Exhibit 1510-6*

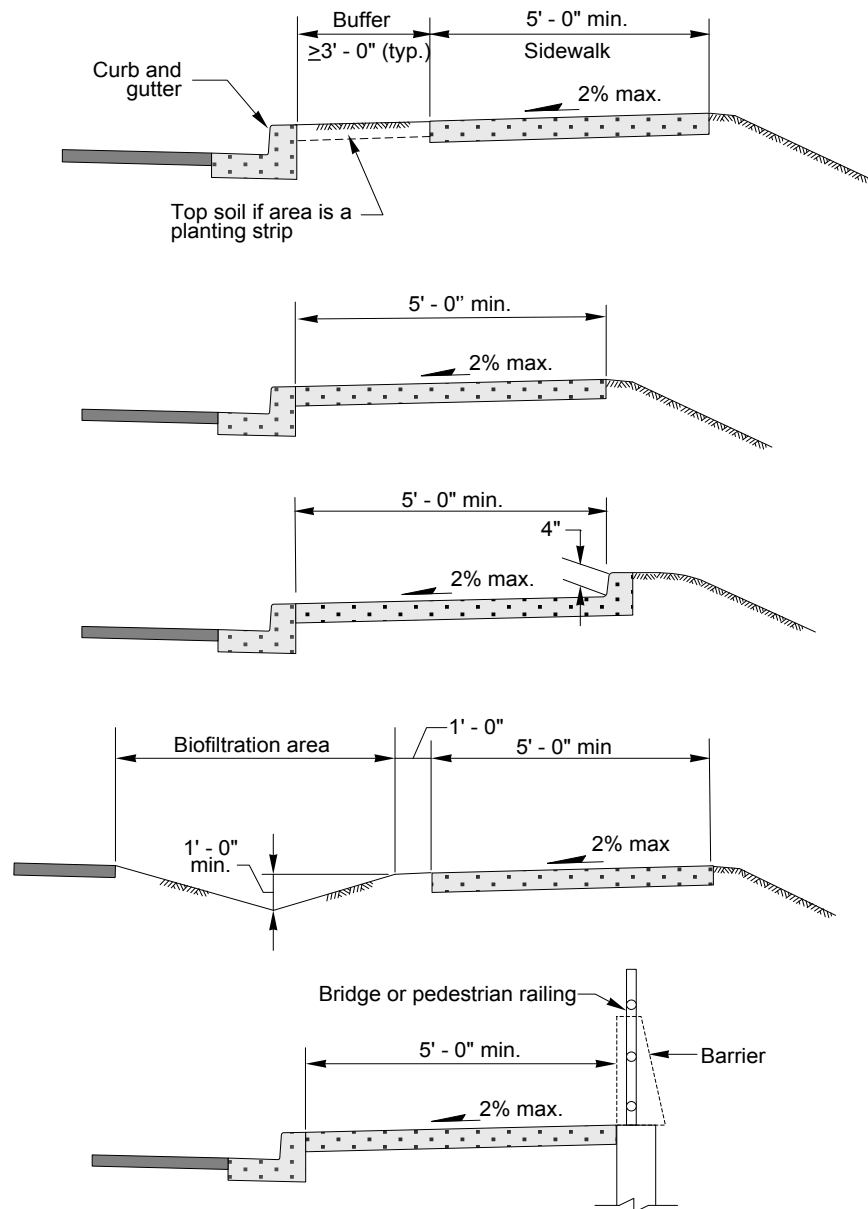

**Notes:**

If vertical drop is within the Design Clear Zone and the posted speed is  $> 35$  mph, then barrier may be needed (see [Chapter 1600](#)).

If vertical drop is  $\geq 2$  feet 6 inches and barrier is not needed, then railing is indicated.

If vertical drop is  $< 2$  feet 6 inches and barrier is not needed, then a 4-inch curb at back of sidewalk is adequate.

**General:**

See the [Standard Plans](#) for details on slopes at back of sidewalk.

See [Chapter 1230](#) for slope selection criteria.

Sidewalks may be sloped away from the roadway for stormwater treatment (see the [Highway Runoff Manual](#)).

**Typical Sidewalk Designs**  
Exhibit 1510-7



### 1510.08(2) Sidewalks at Driveways

Provide a pedestrian access route where driveways intersect a pedestrian circulation path (see [Exhibit 1510-8](#)). The *Standard Plans* shows details of driveway designs that provide a pedestrian access route. (See [1510.06](#) and [1510.07](#) for accessibility criteria.) When a driveway is signalized as part of an intersection, contact the Region ADA Coordinator for guidance.



**Typical Driveways**  
*Exhibit 1510-8*

### 1510.09 Curb Ramps

Curb ramps provide an accessible connection from a raised sidewalk down to the roadway surface. A curb ramp, or combination of curb ramps, is required to connect pedestrian access routes to crosswalks (marked or unmarked) where curbs and sidewalks are present, except where pedestrian crossing is prohibited. (See [1510.10\(2\)\(c\)](#) for guidance on closed crossings and [Exhibit 1510-17](#) for an example.)

For new construction projects, provide a curb ramp oriented in each direction of pedestrian travel within the width of the crosswalk it serves. For alteration projects, a curb ramp oriented in each direction of pedestrian travel within the width of the crosswalk it serves is desirable.

Every curb ramp must have a curb ramp at the other end of the crosswalk it serves unless there is no curb or sidewalk on that side ([RCW 35.68.075](#)).

Curb ramps are also required at midblock crossings where curbs and sidewalks are present.

#### 1510.09(1) Types of Curb Ramps

Different types of curb ramps can be used: perpendicular, parallel, and combination. Carefully analyze and take into consideration drainage patterns, especially when designing a parallel or combination curb ramp installation.

**1510.09(1)(a) Perpendicular Curb Ramp**

Perpendicular curb ramps (see Exhibits 1510-9 and 1510-10) are aligned to cut through the curb and meet the gutter grade break at a right angle. The landing is to be located at the top of the curb ramp.

**1. Advantages**

- Having the path of travel aligned to cross the gutter grade break at a right angle facilitates usage by individuals with mobility devices.
- The height of the ramp run relative to the gutter elevation may facilitate drainage.
- The height of the ramp run relative to the gutter elevation discourages vehicular traffic from cutting across the corner.
- On small-radius corners, the ramp alignment may be more closely aligned with the alignment of the crosswalk markings, which facilitates direction finding for the visually impaired.

**2. Disadvantages**

- The ramp run and landing might not fit within available right of way.
- On small-radius corners, the flares may not fit between closely spaced perpendicular curb ramps.
- On larger-radius corners, there will be less facilitation of direction finding for the visually impaired due to the requirement that the path of travel cross the gutter grade break at a right angle.



**Perpendicular Curb Ramp**  
*Exhibit 1510-9*

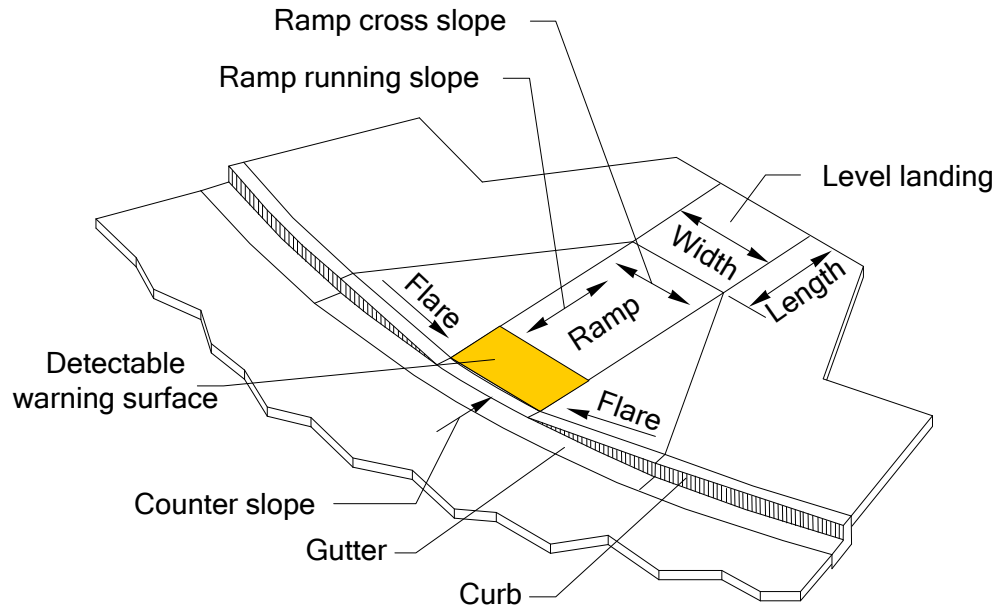

### Perpendicular Curb Ramp Common Elements

*Exhibit 1510-10*

#### 1510.09(1)(b) Parallel Curb Ramp

Parallel curb ramps (see Exhibits 1510-11 and 1510-12) are aligned with their running slope in line with the direction of sidewalk travel, parallel to the curb. The landing is located at the bottom of the curb ramp.

##### 1. Advantages

- Requires minimal right of way.
- Allows ramps to be extended to reduce ramp grade within available right of way.
- Provides edges on the side of the ramp that are detectable to vision-impaired pedestrians who navigate with a cane.

##### 2. Disadvantages

- Depending on the style of parallel curb ramp, pedestrian through traffic on the sidewalk may need to negotiate two ramp grades instead of one, possibly making it more difficult to traverse for some.
- The installation of additional drainage features in the upstream gutter line may be necessary to prevent the accumulation of water or debris in the landing at the bottom of the ramp.



**Parallel Curb Ramp**  
*Exhibit 1510-11*

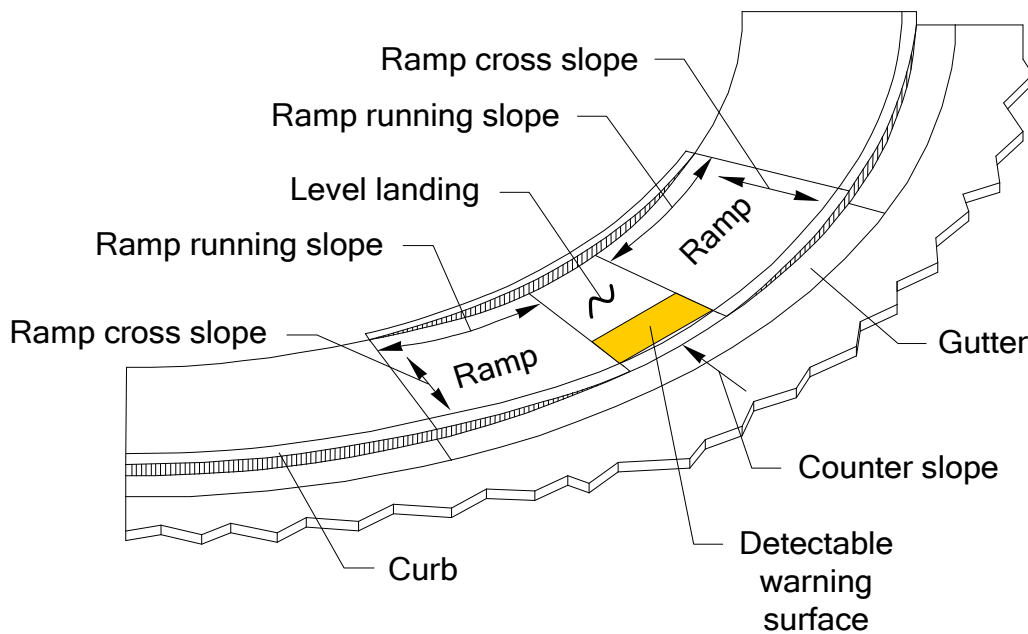

**Note:** The pedestrian curb shown on the back of the curb ramp is intended to retain material in a cut section and is not required if there is no material to retain due to the nature of the roadside topography.

**Parallel Curb Ramp Common Elements**  
*Exhibit 1510-12*

### 1510.09(1)(c) Combination Curb Ramp

Combination curb ramps (see [Exhibit 1510-13](#)) combine the use of perpendicular and parallel types of curb ramps. Landings may be shared by multiple ramps in this application. Buffer areas and pedestrian curbing that define the pedestrian path of travel are inherent design elements for this type of curb ramp.

#### 1. Advantages

- Allows the elevation difference between the sidewalk and the gutter line to be transitioned with multiple ramps. This can help achieve compliant ramp running slopes.
- Provides additional locations in the gutter line along the radius where drainage structures can be placed outside the pedestrian access route due to the well-defined pedestrian paths of travel.
- Can be constructed within available right of way when the right of way boundary is located at the back of the existing sidewalk, provided sufficient buffer width is available on the roadway side of the sidewalk.
- Provides a way to avoid the relocation of existing features such as utility poles, fire hydrants, and signal poles by incorporating those features into the buffer areas.
- The pedestrian curbing that defines the buffer areas and forms the curb returns for the perpendicular ramp connections facilitates direction finding for a vision-impaired person who navigates with a cane.

#### 2. Disadvantages

- Has a higher construction cost than other curb ramp types due to extensive use of curbing and a larger footprint.
- Due to generally flatter ramp grades and multi-tiered ramp elements, inadequate drainage and accumulation of debris can occur.



**Combination Curb Ramps**  
*Exhibit 1510-13*

### 1510.09(2) Accessibility Criteria for Curb Ramps

The accessibility criteria for pedestrian circulation paths and pedestrian access routes (see [1510.06](#) and [1510.07](#)) also apply to curb ramps unless superseded by the following accessibility criteria specifically for curb ramps.

#### 1510.09(2)(a) Clear Width

- The clear width of curb ramps and their landings shall be 4 feet minimum, excluding flares.

#### 1510.09(2)(b) Running Slope

- The running slope of curb ramps shall not exceed 8.3% maximum.

*Note:* It is recommended that running slopes be designed to be less than the allowed maximum to allow for some tolerance in construction. For example, design for a maximum 7.5% curb ramp running slope (rather than the 8.3% maximum).

- The running slope of a perpendicular curb ramp shall intersect the gutter grade break at a right angle at the back of curb.
- The curb ramp maximum running slope shall not require the ramp length to exceed 15 feet.

#### 1510.09(2)(c) Cross Slope

- The cross slope of curb ramp shall not be greater than 2%, measured perpendicular to the direction of travel.

*Note:* It is recommended that cross slopes be designed to be less than the allowed maximum to allow for some tolerance in construction. For example, design for a maximum 1.5% cross slope (rather than the 2% maximum).

*Exception:* The cross slopes of curb ramps at midblock crossings are permitted to match the street or highway grade.

#### 1510.09(2)(d) Landing

A level landing is required either at the top of a perpendicular ramp or the bottom of a parallel curb ramp, as noted in [1510.09\(1\)\(a\)](#) and [\(b\)](#) for the type of curb ramp used.

- Provide a landing that is at least 4 feet minimum length by 4 feet minimum width.
- The running and cross slopes of a curb ramp landing shall be 2% maximum.

*Note:* It is recommended that cross slopes be designed to be less than the allowed maximum to allow for some tolerance in construction. For example, design for a maximum 1.5% cross slope (rather than 2% maximum).

*Exception:* The running and cross slopes of landings for curb ramps at midblock crossings are permitted to match the street or highway grade.

**1510.09(2)(e) Flares**

- Flared sides are to be used only where a pedestrian circulation path crosses the curb ramp from the side.
- Flared sides are to have a slope of 10% maximum, measured parallel to the back of curb.

**1510.09(2)(f) Counter Slope**

- The counter slope of the gutter or street at the foot of a curb ramp or landing shall be 5% maximum.

**1510.09(2)(g) Detectable Warning Surfaces**

- Detectable warning surfaces are required where curb ramps or landings connect to a roadway. (See the *Standard Plans* for placement details and other applications.)
- Detectable warning surfaces shall contrast visually (either light-on-dark or dark-on-light) with the adjacent walkway surface, gutter, street, or highway.

*Note:* Federal yellow is the color used to achieve visual contrast on WSDOT projects. Within cities, other contrasting colors may be used if requested by the city.

**1510.09(2)(h) Surfaces**

- Surfaces of curb ramps shall be firm, stable, and slip resistant.
- Gratings, access covers, utility objects, and other appurtenances shall not be located on curb ramps, landings, or gutters within the pedestrian access route.

**1510.09(2)(i) Grade Breaks**

- Vertical alignment shall be planar within curb ramp runs, landings, and gutter areas within the pedestrian access route.
- Grade breaks at the top and bottom of curb ramps shall be perpendicular to the direction of travel on the ramp run.
- Surface slopes that meet at grade breaks shall be flush.

**1510.09(2)(j) Clear Space**

- Beyond the curb face where the bottom of a curb ramp or landing meets the gutter, a clear space of 4 feet minimum by 4 feet minimum shall be provided in the roadway that is contained within the width of the crosswalk and located wholly outside the parallel vehicle travel lane.

*Note:* Clear space is easily achieved when a separate curb ramp is provided, oriented in each direction of pedestrian travel within the width of the crosswalk it serves.

**1510.09(3) Curb Ramp Drainage**

Surface water runoff from the roadway can flood the lower end of a curb ramp. Provide catch basins or inlets to prevent ponding at the base of curb ramps and landings. [Exhibit 1510-14](#) shows examples of drainage structure locations. Verify that drainage structures will not be located in the pedestrian access route.

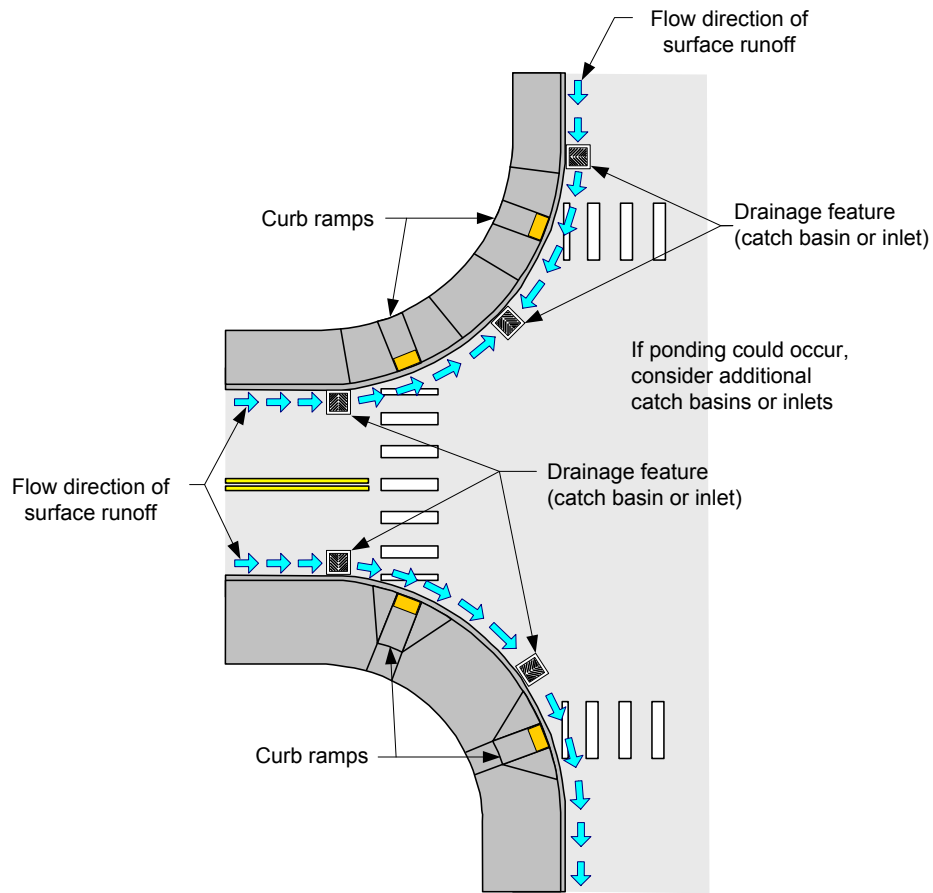

**Typical Curb Ramp Drainage**  
Exhibit 1510-14

## 1510.10 Crosswalks

### 1510.10(1) Designing Crossing Facilities

Evaluate the following for crossing facilities to address the needs of all user modes:

- Minimize turning radii to keep speeds low. (See [Chapter 1300](#) for design vehicle guidance.)
- Place crosswalks so they are visible and connect to the adjacent pedestrian facilities.
- Provide sight distance (driver to pedestrian; pedestrian to driver).
- Use a separate left-turn phase along with a “WALK/DON’T WALK” signal.
- Restrict or prohibit turns.
- Shorten crossing distance.
- Use a raised median/cut-through island for a pedestrian refuge.
- Use accessible pedestrian signals (APS).
- Use signing and delineation as determined by the region Traffic Engineer.
- Place crosswalks as close as practicable to the intersection traveled way.
- Provide pedestrian-level lighting.
- Consider the crosswalk location in relation to transit stops.
- Provide a PAR that meets the accessibility criteria at all pedestrian crossings.



### 1510.10(2) Crosswalks at Intersections

Provide a pedestrian access route within marked and unmarked pedestrian crossings. (See [1510.07](#) for accessibility criteria for pedestrian access routes.) [Exhibit 1510-32](#) provides recommendations for determining pedestrian markings based on lane configuration, vehicular traffic volume, and speed. However, the region Traffic Engineer makes the final determination on appropriate signing and delineation.

#### 1510.10(2)(a) Unmarked Crossings

Legal crosswalks exist at all intersections, whether marked or not, regardless of the number of legs at the intersection. An unmarked crosswalk (see [Exhibit 1510-15](#)) is the portion of the roadway behind a prolongation of the curb or edge of the through traffic lane and a prolongation of the farthest sidewalk connection or, in the event there are no sidewalks, between the edge of the through traffic lane and a line 10 feet from there ([RCW 46.04.160](#)).

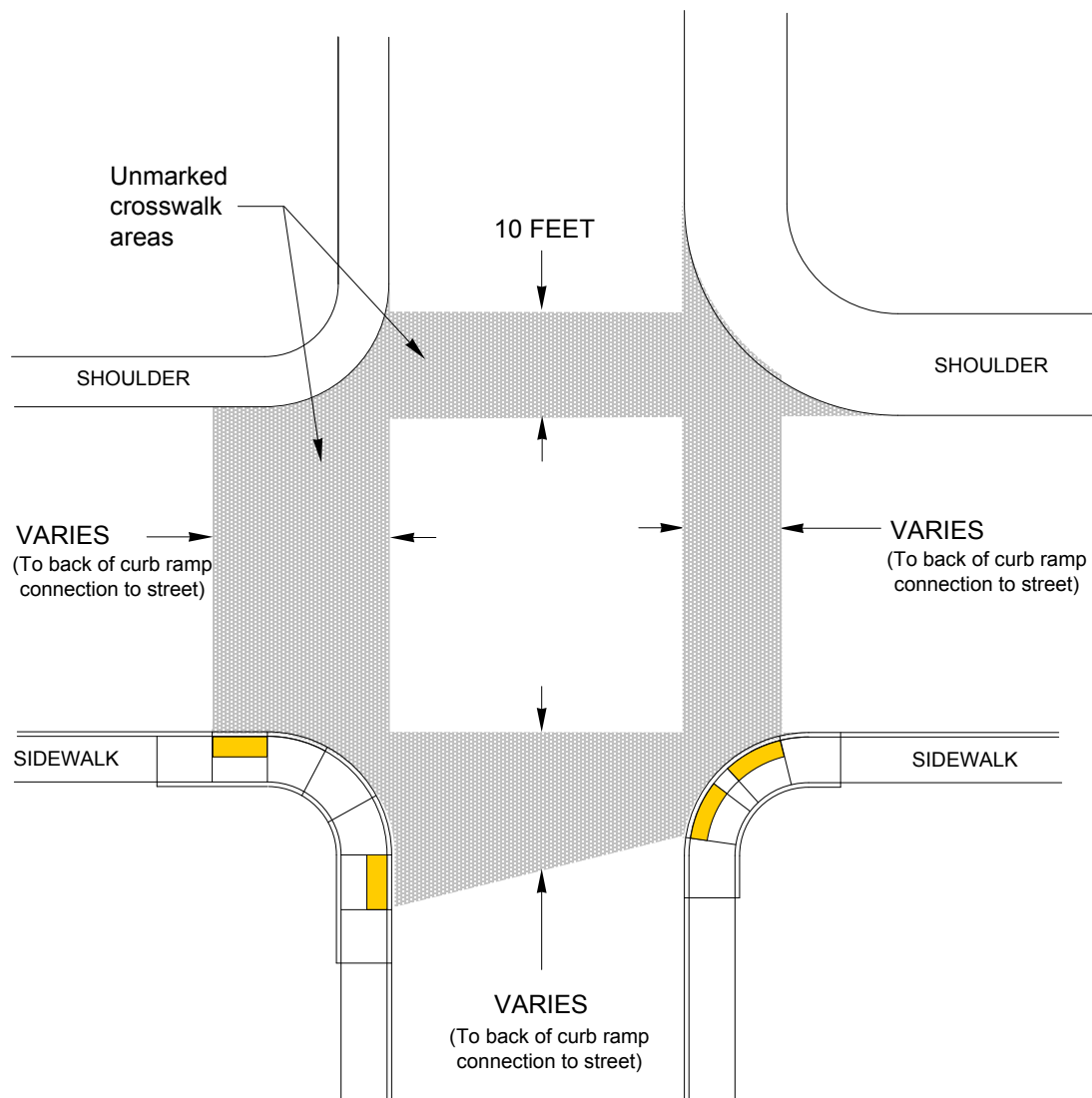

**Unmarked Crosswalks**  
*Exhibit 1510-15*

**1510.10(2)(b) Marked Crossings**

Marked crosswalks are used at intersections or midblock crossings. They are not to be used indiscriminately. Maintenance agreements and [RCW 47.24.020\(30\)](#) provide jurisdictional authority for decisions to mark crosswalks based on a population threshold of 25,000 and should be consulted prior to a decision to mark a crosswalk. Consult region Traffic Offices for “best practices” for marking crosswalks based on intersection type. The [MUTCD](#) is a good resource to use when evaluating locations for marking consideration.

**Note:** The installation of a midblock pedestrian crossing on a state highway is a design deviation that requires ASDE approval.

The desirable width for a marked crosswalk is 10 feet (6 feet minimum, with justification). The preferred type of marked crosswalk is a longitudinal pattern known as a Ladder Bar, which is shown in the [Standard Plans](#) and [Exhibit 1510-16](#). Stop and yield line dimensions and placement must conform to the [MUTCD](#) and are shown in the [Standard Plans](#).

Some decorative crosswalk materials (such as colored pavement or bricks) may cause confusion for visually impaired pedestrians and can create discomfort for wheelchair users. Supplement decorative crosswalks with pavement markings to enhance visibility and delineate the crosswalk. Refer to the [MUTCD](#) and the Local Agency Crosswalk Options website:

[www.wsdot.wa.gov/design/standards/plansheet/pm-2.htm](http://www.wsdot.wa.gov/design/standards/plansheet/pm-2.htm)

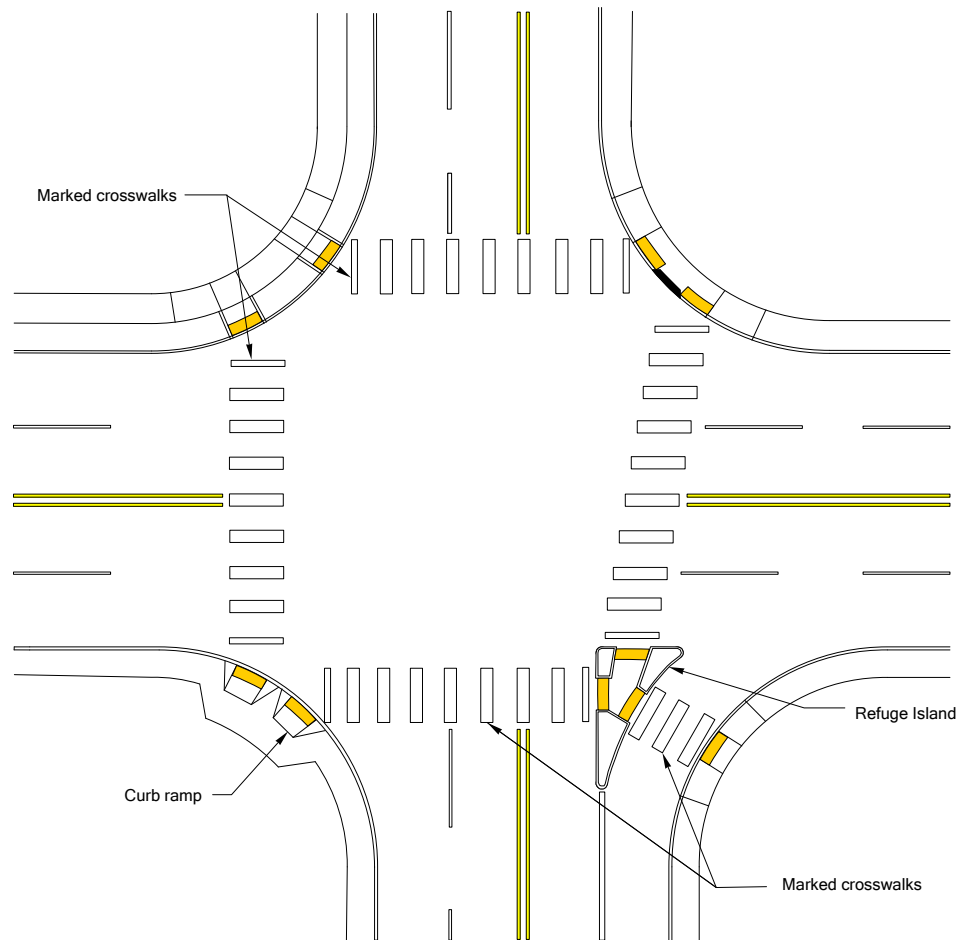

**Marked Pedestrian Crossing**  
*Exhibit 1510-16*

### 1510.10(2)(c) Closed Crossings

Pedestrian crossing at grade on all legs of an intersection is permitted, whether a crosswalk is marked or unmarked ([RCW 46.61.240](#)). To close a crossing at an intersection, use raised channelization, traffic barrier, or appropriate signing. Consider providing a treatment at closed crossings that is detectable by people with vision difficulties who navigate with a cane, such as directional pedestrian curbing. An example of a closed pedestrian crossing with directional pedestrian curbing is shown in [Exhibit 1510-17](#). Consult with the region Traffic Office when considering closing a crossing. The region Traffic Engineer is the approval authority for closed crossings.

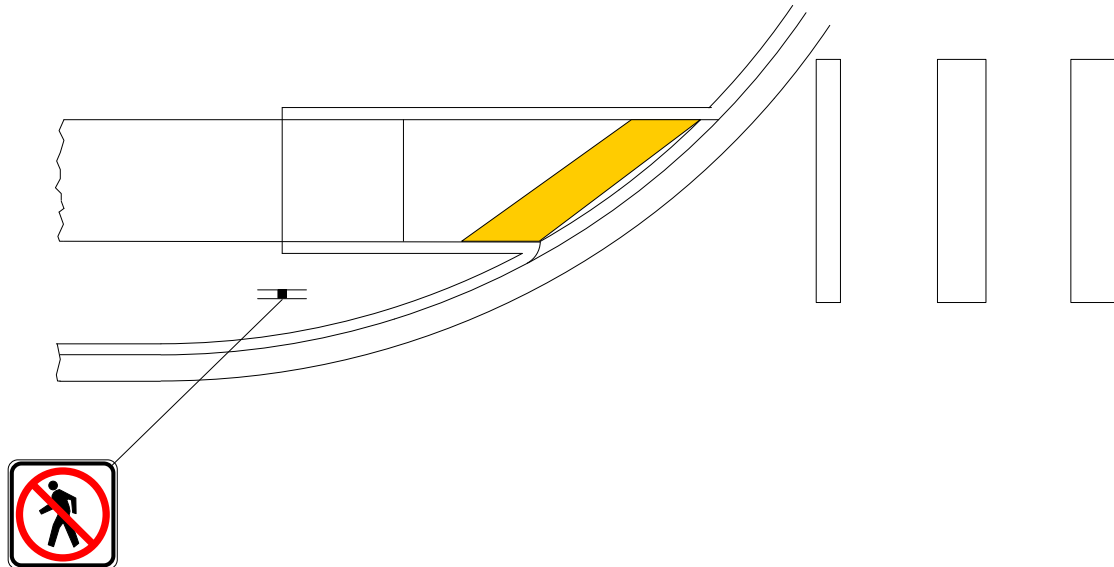

**Note:** See the [Standard Plans](#) for additional details.

#### Example of Closed Pedestrian Crossing *Exhibit 1510-17*

### 1510.10(3) Midblock Crosswalks

On roadways with pedestrian crossing traffic caused by nearby pedestrian generators, a midblock crossing may be appropriate. (See [1510.10\(2\)](#) for crosswalk criteria and [Exhibit 1510-32](#) for marked crosswalk recommendations at unsignalized intersections.)

Engineering judgment of conditions that might favor a midblock crossing includes the following:

- High pedestrian crossing volume present with long block spacing.
- Evidence of pedestrian-vehicular midblock conflicts (site observations, law enforcement reporting, and city traffic engineers).
- Proposed crossing with a realistic opportunity to channel multiple pedestrian crossings to a single location.
- Sight lines that enable sufficient eye contact between motorists and pedestrians.
- Community commitment for a successful outcome.
- Ability to mitigate risks associated with the location using proven countermeasures such as, but not limited to, refuge islands, rectangular rapid flashing beacons, and/or pedestrian hybrid beacons.

To meet the accessibility criteria, the pedestrian access route in the crosswalk at a midblock crossing may have a cross slope that matches the grade of the roadway. Note that the installation of a midblock pedestrian crossing on a state highway is a design deviation that requires ASDE approval. An example of a midblock crossing is shown in [Exhibit 1510-18](#).



**Midblock Pedestrian Crossing**  
*Exhibit 1510-18*

#### **1510.10(4) Sight Distance at Crosswalks**

When locating crosswalks at intersections, it is important to evaluate the sight lines between pedestrians and motorists. Shrubbery, signs, parked cars, and other roadside elements can block motorists' and pedestrians' views of one another. [Exhibit 1510-19](#) illustrates these sight distance concerns.

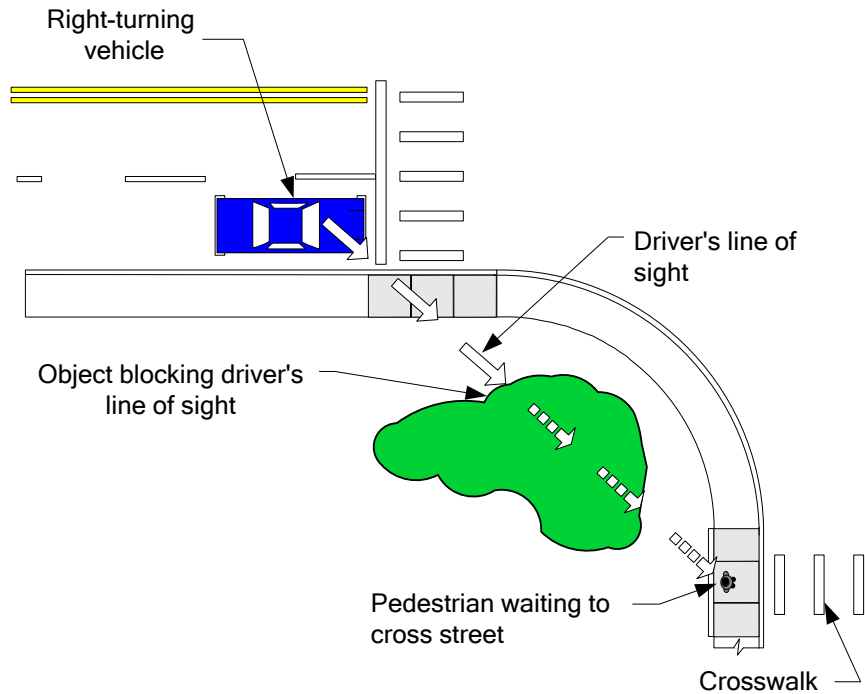
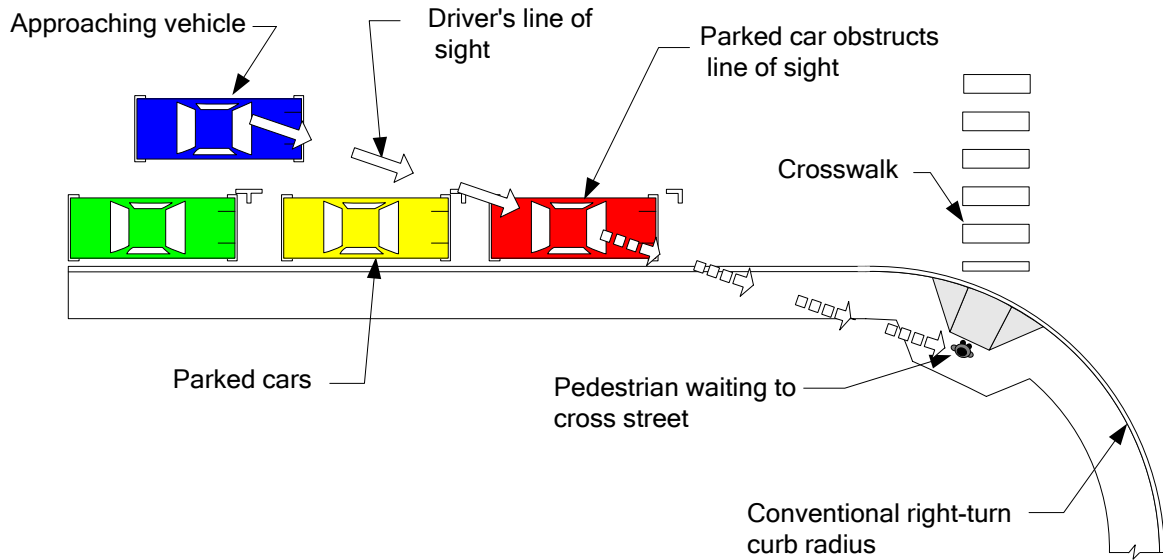

**Obstructed Line of Sight at Intersection**

*Exhibit 1510-19*

**1510.10(5) Curb Extensions**

Curb extensions are traffic calming measures that may improve sight distance and reduce pedestrian crossing times, which limits pedestrian exposure. Installing a curb extension can help reduce the sight distance problem with parked cars that limit driver/pedestrian visibility. Curb extensions may allow for better curb ramp design as well as provide more space for pedestrians.

**Note:** Curb extensions are not an option on streets with high-speed traffic or without on-street parking because drivers would be confronted with sudden changes in roadway width.

Extend the curb no farther than the width of the parking lane. (See Chapters 1130, 1140, and 1520 for shoulder/bike lane width guidance.) Design the approach nose to ensure adequate setback of vehicles to provide visibility of pedestrians. At intersections with traffic signals, the curb extensions can be used to reduce pedestrian signal timing. Examples of sidewalk curb extensions are shown in Exhibits 1510-20 and 1510-21.

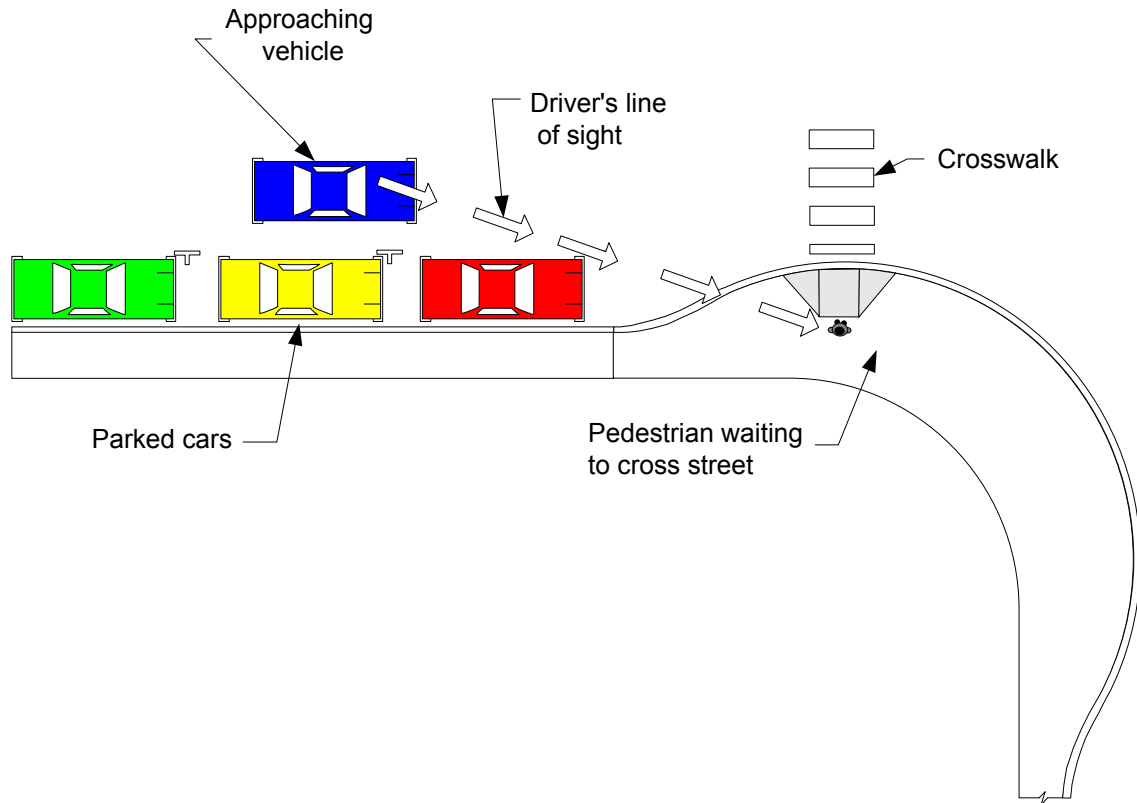

**Improved Line of Sight at Intersection**  
*Exhibit 1510-20*



**Curb Extension Examples**  
*Exhibit 1510-21*

The right-turn path of the design vehicle is a critical element in determining the size and shape of the curb extension. Sidewalk curb extensions tend to restrict the width of the roadway and can make right turns difficult for large trucks. Ensure the geometry of the curb extension is compatible with the turn path for the design vehicle selected.

Avoid interrupting bicycle traffic with curb extensions.

Do not use curb extensions on state highways when:

- The design vehicle (see [Chapter 1300](#)) encroaches on curbs or opposing lanes, and other solutions will not improve the circumstances.
- On-street parking is not provided/allowed.
- The posted speed is above 35 mph.

Site features such as landscaping, cabinets, poles, benches, planters, bollards, newspaper stands, and sandwich boards should be selected and placed so they do not obstruct the vision of pedestrians or drivers within curb extension areas, as shown in [Exhibit 1510-21](#). Take into account motorist and pedestrian visibility and Design Clear Zone guidelines (see [Chapter 1600](#)).

### 1510.11 Raised Medians/Traffic Islands

Wide multilane streets are often difficult for pedestrians to cross, particularly when there are insufficient gaps in vehicular traffic because of heavy volumes. Consider raised medians and traffic islands with a pedestrian refuge area (see [Exhibit 1510-22](#)) on roadways with the following conditions:

- Two-way arterial with intermediate to high speeds (35 mph or greater), moderate to high average daily traffic (ADT), and high pedestrian volumes.
- Significant pedestrian collision history.
- Near a school or other community center.
- Crossing distance exceeds 30 feet.
- Complex or irregularly shaped intersections.

A traffic island used for channelized right-turn slip lanes can provide a pedestrian refuge, but the slip lane may promote faster turning speeds. Minimize the turning radius of the slip lane to keep speeds as low as feasible. To reduce conflicts, keep the slip lane as narrow as practicable and design a crosswalk alignment that is at a right angle to the face of curb. (See [Chapters 1310](#) for turn lanes, [1360](#) for interchange ramps, and [1320](#) for pedestrian accommodations in roundabouts.)

The pedestrian access route through a raised median or traffic island can be either raised with curb ramps or a cut-through type (see [Exhibit 1510-22](#)). Curb ramps in medians and islands can add difficulty to the crossing for some users. The curbed edges of cut-throughs can be useful cues to the visually impaired in determining the direction of a crossing, especially on an angled route through a median or island.

### 1510.11(1) **Accessibility Criteria for Raised Medians and Traffic Islands**

There are many design considerations when deciding whether to ramp up to the median or island grade or create a cut-through median or island matching the roadway grade. These considerations may include the profile grade and cross slope of the road, drainage patterns, and the length or width of the median or island.

The following accessibility criteria apply:

- Each raised median or traffic island shall contain a pedestrian access route connecting to each crosswalk (see [1510.07](#)).
- A passing space shall be provided that is at least 5 feet wide for a distance of at least 5 feet for each pedestrian access route in a raised median or on a traffic island (see [Exhibit 1510-22](#)).

**Note:** It is recommended that cut-throughs be designed to have a minimum width of 5 feet to ensure a passing space is provided.

- Medians and pedestrian refuge islands shall be 6 feet minimum in length in the direction of pedestrian travel.
- Detectable warning surfaces are to be separated by 2 feet minimum length in the direction of pedestrian travel.
- Detectable warning surfaces are located at each curb ramp or roadway entrance of a pedestrian access route through a raised median or traffic island. The detectable warning surface shall be located at the back of the curb (see [Exhibit 1510-22](#)).
- Pedestrian access routes of shared-use paths that go through raised medians or traffic islands shall be the same width as the shared-use path (see [Chapter 1515](#)).





Island Cut-Through

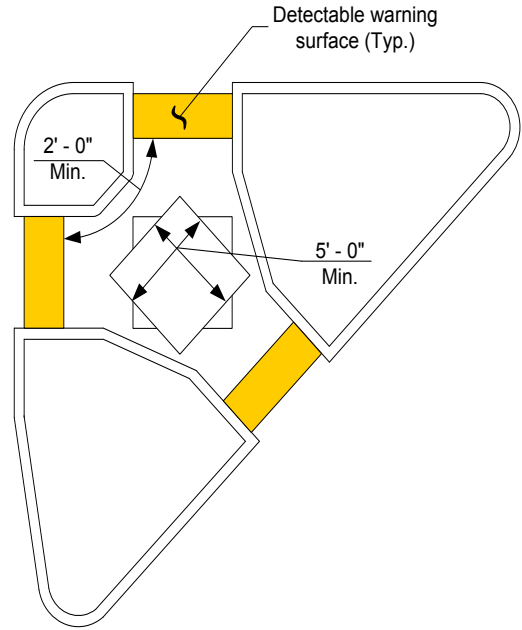

Island Cut-Through

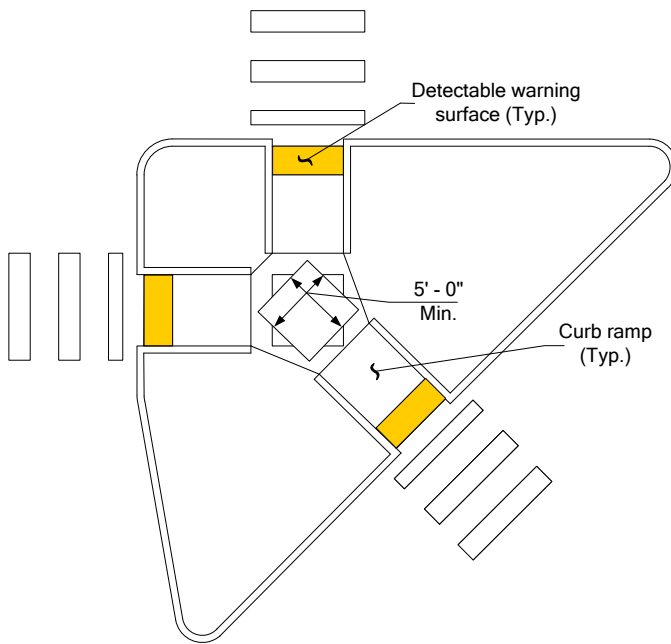

Raised Traffic Island With Curb Ramps

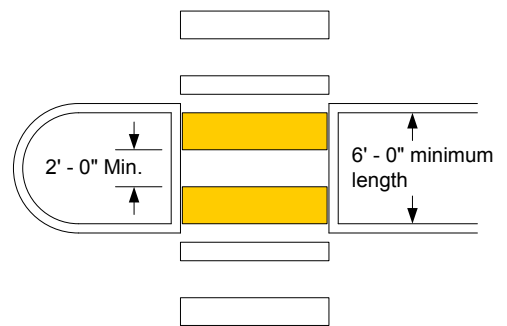

Median Island Cut-Through (full width shown)  
(See 1510.11(1) for minimum accessibility criteria.)

See the [Standard Plans](#) for details.

**Raised Islands With Curb Ramps and Pedestrian Cut-Throughs**  
*Exhibit 1510-22*

## 1510.12 Pedestrian Pushbuttons at Signals

When designing pedestrian signals, consider the needs of all pedestrians, including older pedestrians and pedestrians with disabilities who might walk at a significantly slower pace than the average pedestrian. Determine whether there are pedestrian generators in the project vicinity that might attract older people and pedestrians with disabilities, and adjust signal timing accordingly. When pedestrian signals are newly installed, replaced, or significantly modified, include accessible pedestrian signal (APS) pushbuttons and countdown pedestrian displays as described in [1510.12\(2\)](#).



**Typical Pedestrian Pushbutton**  
*Exhibit 1510-23*

### **1510.12(1) Accessibility Criteria for All Pedestrian Pushbuttons (including APS)**

#### **1510.12(1)(a) Location Requirements**

- Not greater than 5 feet from the crosswalk line (extended) that is farthest from the center of the intersection.
- Between 1½ feet and 10 feet from the edge of the curb, shoulder, or pavement.
- Mounting height: 42 inches desirable, 48 inches maximum, 15 inches minimum.

#### **1510.12(1)(b) Clear Space Requirements**

- Grade: 2% maximum running and cross slopes.
- Clear space dimensions: 30 inches minimum width by 48 inches minimum length (see [Exhibit 1510-24](#)).
- Clear space is allowed to overlap other PAR elements (i.e., sidewalk/curb ramp landing).
- Clear space must be connected to the crosswalk served by the pedestrian pushbutton with a PAR.
- Additional maneuvering space may be required if the clear space is constrained on three sides (see PROWAG).

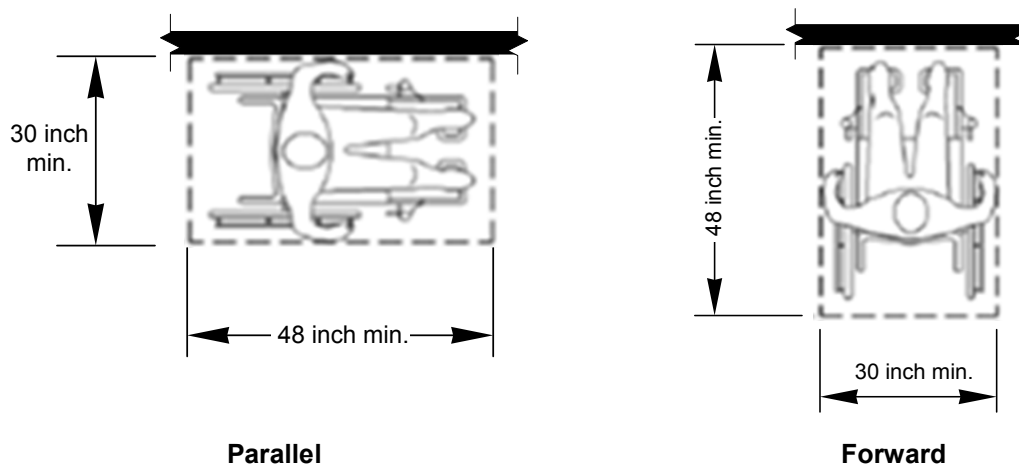

**Note:** A desirable clear space accommodates the full spectrum of wheeled mobility device users approaching the pedestrian pushbutton from multiple directions. Consider providing 36 inches width and up to 84 inches length designed for a parallel approach with the pedestrian pushbutton centered within the length.

### Clear Space Parallel and Forward Approach Orientation

*Exhibit 1510-24*

#### 1510.12(1)(c) Reach Range Requirements

- The provided clear space must be within reach range of the pedestrian pushbutton.
- For a parallel approach pedestrian pushbutton that has a mounting height greater than 46 inches and not more than 48 inches, the reach range is 10 inches maximum.
- For a parallel approach pedestrian pushbutton that has a mounting height 46 inches or less, the reach range is 24 inches maximum; however, design for 10 inches or less reach range whenever possible.
- For a forward approach pedestrian pushbutton, the reach range is 0 (zero) inches maximum regardless of mounting height. The pushbutton must either be placed at the very edge of the clear space or extend into the clear space while providing knee and toe clearance for a wheeled mobility device user (see PROWAG).

**Note:** Due to the challenges associated with providing reach range, it is desirable to design clear space for a parallel approach whenever possible.

#### 1510.12(2) Accessible Pedestrian Signals (APS)

At all locations where pedestrian signals are newly installed, replaced, or significantly modified, the installation of accessible pedestrian signals and countdown pedestrian displays is required.

**Note:** Simply moving existing pedestrian pushbuttons to satellite poles to improve accessibility is not by itself considered a significant modification of the pedestrian signal.

When APS and countdown pedestrian display improvements are made, they shall be made for all locations associated with the system being improved. APS includes audible and vibrotactile indications of the WALK interval. Installation of these devices may require improvements to existing sidewalks and curb ramps to ensure ADA compliance.



### Accessible Pedestrian Signal Pushbutton Stations

*Exhibit 1510-25*

#### 1510.12(3) Accessibility Criteria for Accessible Pedestrian Signals (APS)

In addition to the general pedestrian pushbutton accessibility criteria described in [1510.12\(1\)](#), the following criteria apply to APS installations:

- APS pushbuttons shall have a locator tone that operates during the DON'T WALK and the flashing DON'T WALK intervals only.
- APS pushbuttons must have both audible and vibrotactile indications of the WALK interval.
- APS pushbutton controls and signs shall be installed facing the intersection and be parallel to the crosswalk served.
- An APS pushbutton shall have a tactile arrow that indicates the crossing direction activated by the pushbutton.
- An APS pushbutton provides high contrast (light-on-dark or dark-on-light) against its background.
- If extended pushbutton press features are available, the APS pushbutton shall be marked with three braille dots forming an equilateral triangle in the center of the pushbutton.
- If additional crossing time is provided by an extended pushbutton press feature, then an R10-32P (MUTCD) plaque shall be mounted adjacent to or integral with the APS pushbutton.
- If the pedestrian clearance time is sufficient only to cross from the curb or shoulder to a median to wait for the next cycle, then an additional APS pushbutton shall be provided in the median.
- The desirable spacing between the APS pushbuttons is 10 feet minimum (5 feet minimum spacing on medians and islands), if feasible.
- If the spacing between the APS pushbuttons is 10 feet or greater, the audible WALK indication shall be a percussive tone.
- If the spacing between the APS pushbuttons is less than 10 feet, the audible WALK indication shall be a speech walk message, and a speech pushbutton information message shall be provided.

Refer to the [MUTCD](#) for further design guidance. Also, consult with HQ Traffic Operations and either region or city maintenance personnel (as appropriate) for current equipment specifications and additional maintenance requirements.

### 1510.13 At-Grade Railroad Crossings

The design of pedestrian facilities that cross railroad tracks (see [Exhibit 1510-26](#)) often presents challenges due to the conflicting needs of pedestrians and trains. In particular, the flangeway gap for trains to traverse a crossing surface may create a significant obstacle for a person who uses a wheelchair, crutches, or walking aids for mobility. Whenever practicable, align pedestrian crossings perpendicular to the tracks in order to minimize potential problems related to flangeway gaps. Crossing surfaces may be constructed of timber planking, rubberized materials, or concrete. Concrete materials generally provide the smoothest and most durable crossing surfaces. When detectable warning surfaces are used at railroad crossings, place them according to the [MUTCD](#) stop line placement criteria.



Undesirable

Recommended

#### Pedestrian Railroad Crossings

*Exhibit 1510-26*

There are a number of railroad crossing warning devices (see [Exhibit 1510-27](#)) intended specifically for pedestrian facilities (see the [MUTCD](#)). When selecting warning devices, factors such as train and pedestrian volumes, train speeds, available sight distance, number of tracks, and other site-specific characteristics should be taken into account. Coordinate with the HQ Design Office Railroad Liaison early in the design process so that all relevant factors are considered and an agreement may be reached regarding the design of warning devices and crossing surfaces.



#### Pedestrian Railroad Warning Device

*Exhibit 1510-27*

Except for crossings located within the limits of first-class cities,\* the Washington Utilities and Transportation Commission (WUTC) approves proposals for any new railroad at-grade crossings or changes to warning devices or geometry at existing crossings. Additionally, any project that requires the railroad to perform work such as installation of warning devices or crossing surfaces must obtain a railroad construction and maintenance agreement. Contact the HQ Design Office Railroad Liaison to coordinate with both the WUTC and the railroad company.

\*[RCW 35.22.010](#): A first class city is a city with a population of ten thousand or more at the time of its organization or reorganization that has a charter adopted under Article XI, section 10, of the state Constitution.

**Note:** There are very few first-class cities in the state of Washington. Verify with the HQ Design Office Railroad Liaison.

### 1510.14 Pedestrian Grade Separations (Structures)

On the approach to a bridge that has a raised sidewalk, provide a ramp that transitions to the sidewalk from the paved shoulder. A ramp that transitions from a paved shoulder to a sidewalk on a bridge is to have a slope of 5% maximum and be constructed of asphalt or cement concrete. In addition to aiding pedestrian access, the ramp also serves as a roadside safety feature to mitigate the raised blunt end of the concrete sidewalk. If a pedestrian circulation path (such as a raised sidewalk or shared-use path) is located near the bridge, consider eliminating the gap between the bridge sidewalk and the pedestrian circulation path by extending the bridge sidewalk to match into the nearby pedestrian circulation path.

At underpasses where pedestrians are allowed, it is desirable to provide sidewalks and to maintain the full shoulder width. When bridge columns are placed on either side of the roadway, it is preferred to place the walkway between the roadway and the columns for pedestrian visibility and security. Provide adequate illumination and drainage for pedestrian safety and comfort.

In cases where there is a pedestrian collision history, and the roadway cannot be redesigned to accommodate pedestrians at grade, planners should consider providing a grade-separated pedestrian structure (see Exhibits [1510-28](#) and [1510-29](#)). When considering a grade-separated pedestrian structure, determine whether the conditions that require the crossing are permanent. If there is likelihood that pedestrians will not use a grade separation, consider less-costly solutions.

Locate the grade-separated crossing where pedestrians are most likely to cross the roadway. A crossing might not be used if the pedestrian is required to deviate significantly from a more direct route.

It is sometimes necessary to install fencing or other physical barriers to channel the pedestrians to the structure and reduce the possibility of undesired at-grade crossings. **Note:** The HQ Bridge and Structures Office is responsible for the design of pedestrian structures.

Consider a grade-separated crossing where:

- There is moderate to high pedestrian demand to cross a freeway or expressway.
- There are large numbers of young children, particularly on school routes, who regularly cross high-speed or high-volume roadways.
- The traffic conflicts that would be encountered by pedestrians are considered unacceptable (such as on wide streets with high pedestrian volumes combined with high-speed traffic).
- There are documented collisions or close calls involving pedestrians and vehicles.

- One or more of the conditions stated above exists in conjunction with a well-defined pedestrian origin and destination (such as a residential neighborhood across a busy street from a school).

### 1510.14(1) Pedestrian Bridges

Pedestrian grade-separation bridges (see [Exhibit 1510-28](#)) are more effective when the roadway is below the natural ground line, as in a cut section. Elevated grade separations in cut sections, where pedestrians climb stairs or use long approach ramps, tend to be underused. Pedestrian bridges need adequate right of way to accommodate accessible ramp approaches leading up to and off of the structure. The bridge structure must comply with ADA requirements and meet the accessibility criteria for either a pedestrian circulation path (if the grade is 5% or less) or an access ramp (if the grade is greater than 5% but less than or equal to 8.3%), and must include a pedestrian access route. (See [1510.06](#) and [1510.07](#) for pedestrian circulation path and pedestrian access route accessibility criteria; see [1510.15\(2\)](#) for access ramp accessibility criteria.)

For the minimum vertical clearance from the bottom of the pedestrian structure to the roadway beneath, see [Chapter 720](#). The height of the structure can affect the length of the pedestrian ramp approaches to the structure. When access ramps are not feasible, provide both elevators and stairways.

Provide railings on pedestrian bridges. Protective screening is sometimes desirable to deter pedestrians from throwing objects from an overhead pedestrian structure (see [Chapter 720](#)).

The minimum clear width for pedestrian bridges is 8 feet. Consider a clear width of 14 feet where a pedestrian bridge is enclosed or shared with bicyclists, or equestrians, or if maintenance or emergency vehicles will need to access.



**Pedestrian Bridges**  
*Exhibit 1510-28*

### 1510.14(2) Pedestrian Tunnels

Tunnels are an effective method of providing crossings for roadways located in embankment sections. Well-designed tunnels can be a desirable crossing for pedestrians. When feasible, design the tunnel with a nearly level profile to provide an unobstructed line of sight from portal to portal (see [Exhibit 1510-29](#)). People may be reluctant to enter a tunnel with a depressed profile because they are unable to see whether the tunnel is occupied. Law enforcement also has difficulty patrolling depressed profile tunnels.

Provide vandal-resistant daytime and nighttime illumination within the pedestrian tunnel. Installing gloss-finished tile walls and ceilings can enhance light levels within the tunnel. The minimum overhead clearance for a pedestrian tunnel is 10 feet. The minimum width for a pedestrian tunnel is 12 feet. Consider a tunnel width between 14 and 18 feet depending on usage and the length of the tunnel.



**Pedestrian Tunnel**  
*Exhibit 1510-29*

Pedestrian tunnels need adequate right of way to accommodate accessible approaches leading to the tunnel structure. The tunnel structure must comply with ADA requirements and meet the accessibility criteria for either a pedestrian circulation path (if the grade is less than or equal to 5%) or an access ramp (if the grade is greater than 5% and less than or equal to 8.3%), and must include a pedestrian access route. (See [1510.06](#) and [1510.07](#) for pedestrian circulation path and pedestrian access route accessibility criteria; see [1510.15\(2\)](#) for access ramp accessibility criteria.)

## 1510.15 Other Pedestrian Facilities

### 1510.15(1) Transit Stops and School Bus Stops

The location of transit stops is an important element in providing appropriate pedestrian facilities. (Coordinate with the local transit provider.) Newly constructed transit stops must conform to ADA requirements. Design newly constructed transit stops so that they are accessible from the sidewalk or paved shoulder. A transit stop on one side of a street usually has a counterpart on the opposite side because transit routes normally function in both directions on the same roadway. Provide adequate crossing facilities for pedestrians.

When locating a transit stop, consider transit ridership and land use demand for the stop. Also, take into account compatibility with the following roadway/traffic characteristics:

- ADT
- Traffic speed
- Crossing distance
- Collision history
- Sight distance
- Connectivity to a pedestrian access route
- Traffic generator density



If any of these suggests an undesirable location for a pedestrian crossing, consider a controlled crossing or another location for the transit stop.

When analyzing a transit stop location with high pedestrian collision rates, take into account the presence of nearby transit stops and opportunities for pedestrians to reasonably safely cross the street. At-grade midblock pedestrian crossings may be effective at transit stop locations on roadways with lower vehicular volumes. Pedestrian grade separations are appropriate at midblock locations when vehicular traffic volumes prohibit pedestrian crossings at grade. (See [Exhibit 1510-32](#) for recommendations for marked crosswalks at unsignalized intersections.)

School bus stops are typically adjacent to sidewalks in urban areas and along shoulders in rural areas. Determine the number of children using the stop and provide a waiting area that allows the children to wait for the bus. Coordinate with the local school district. Because of their smaller size, children might be difficult for motorists to see at crossings or stops. Determine whether utility poles, vegetation, and other roadside features interfere with motorists' ability to see the children. When necessary, remove or relocate the obstructions or move the bus stop. Parked vehicles can also block visibility, and parking prohibitions might be advisable near the bus stop. Coordinate transit and school bus stop locations with the region Traffic Office.

### **1510.15(2) Access Ramps Serving Transit Stops, Park & Ride Lots, Rest Areas, Buildings, and Other Facilities**

An access ramp (see [Exhibit 1510-30](#)) provides an accessible pedestrian route from a pedestrian circulation path to a facility such as a transit stop, park & ride lot, rest area, pedestrian overcrossing/undercrossing structure, or building. When the running slope is 5% or less, it can be designed as a pedestrian circulation path that includes a pedestrian access route. When the running slope is greater than 5% to a maximum of 8.3%, it must be designed as an access ramp. (See [1510.06](#) and [1510.07](#) for pedestrian circulation path and pedestrian access route accessibility criteria; see [1510.15\(2\)\(a\)](#) for access ramp accessibility criteria.)

#### **1510.15(2)(a) Accessibility Criteria for Access Ramps**

Access ramps are composed of one or more ramp segments interconnected by level landings. Unless superseded by the following specific accessibility requirements for access ramps, the accessibility requirements for pedestrian access routes also apply:

- Ramp segments shall have a maximum running slope of 8.3%.
- The cross slope of ramp segments shall be 2% maximum.
- The minimum clear width of ramps is 4 feet; however, it is desirable to match the width of the connecting pedestrian facility.
- The rise for any ramp segment shall be 30 inches maximum.
- A level landing (2% maximum running and cross slopes) shall be provided at the top and bottom of each access ramp segment.
- An access ramp landing's clear width shall be at least as wide as the widest ramp segment leading to the landing.
- An access ramp landing's length shall be 5 feet minimum.
- Access ramps that change direction between ramp segments at landings shall have a level landing 5 feet minimum width by 5 feet minimum length.
- All access ramp segments with a rise greater than 6 inches shall have ADA-compliant handrails (see [1510.15\(3\)](#) for handrail accessibility criteria).

Provide edge protection complying with one of the two following options on each side of access ramp segments:

- The surface of the ramp segment and landing shall extend 12 inches minimum beyond the inside face of the handrail.
- A curb or barrier shall be provided that does not allow the passage of a 4-inch-diameter sphere, where any portion of the sphere is within 4 inches of the ramp/landing surface.



**Access Ramp With Accessible Handrails**  
*Exhibit 1510-30*

### **1510.15(3) Railings and Handrails for Pedestrian Facilities**

Accessible handrails are required on stairs and also on access ramps that have a rise greater than 6 inches (see [1510.15\(2\)\(a\)](#) for access ramp accessibility criteria). If the height of a drop-off (typically greater than 30 inches) adjacent to a pedestrian facility necessitates the need to protect pedestrians from falls, then a more robust railing system designed for fall protection should be used. If the drop-off is adjacent to either a stairway or an access ramp with a rise greater than 6 inches, then a combined railing system that meets the requirements for both accessibility and fall protection must be used.

#### **1510.15(3)(a) Fall Protection Railing**

Railing designed for fall protection alone is typically placed adjacent to pedestrian facilities other than stairs or access ramps to prevent pedestrians or bicyclists from falls. The minimum railing height for pedestrian fall protection is 42 inches. For facilities where bicycle traffic is anticipated, such as on a grade-separation structure on a shared-use facility (see [Chapter 1515](#)), the minimum railing height for bicyclist fall protection is 54 inches.

#### **1510.15(3)(b) Accessible Fall Protection Railing**

When fall protection is needed adjacent to stairs or an access ramp that has a rise greater than 6 inches, then a combined railing system that meets both the accessibility criteria for handrail outlined in [1510.15\(3\)\(d\)](#) and the requirements for fall protection must be used. The minimum railing height for pedestrian fall protection is 42 inches. For facilities where bicycle traffic is anticipated, such as on the approach to a grade-separation structure on a shared-use facility (see [Chapter 1515](#)), the minimum railing height for bicyclist fall protection is 54 inches.

**1510.15(3)(c) Accessible Handrail**

Accessible handrail meeting the accessibility criteria listed in 1510.15(3)(d) that is not designed to provide fall protection is to be used adjacent to stairs or access ramps that have a rise greater than 6 inches at locations where robust fall protection is not needed.

**1510.15(3)(d) Accessibility Criteria for Handrail**

The following accessibility criteria apply to all handrail installations provided at stairs and access ramps that have a rise greater than 6 inches.

**1. Height**

- The top of handrail gripping surfaces shall be 34 inches minimum and 38 inches maximum vertically above walking surfaces, stair nosings, and ramp surfaces.
- The mounting height of the handrail shall also be at a consistent height.

**2. Gripping Surface**

- Clearance between handrail gripping surfaces and adjacent surfaces shall be 1½ inches minimum.
- Handrail gripping surfaces shall be continuous along their length and shall not be obstructed along their tops or sides.
- The bottoms of handrail gripping surfaces shall not be obstructed for more than 20% of their length.
- Where provided, horizontal projections shall be located 1½ inches minimum below the bottom of the handrail gripping surface.
- Handrail gripping surfaces with a circular cross section shall have an outside diameter between 1¼ inches minimum and 2 inches maximum.
- Handrail gripping surfaces with a noncircular cross section shall have a perimeter dimension between 4 inches minimum and 6¼ inches maximum, and a cross section dimension of 2¼ inches maximum.
- Handrail gripping surfaces and the surfaces adjacent to them shall be free of sharp or abrasive elements and shall have rounded edges.
- Handrails shall not rotate in their fittings.

**3. Placement and Continuity**

- Handrails shall be provided on both sides of access ramps and stairs.
- Handrails shall be continuous within the full length of each access ramp run or stair flight.
- Inside handrails on switchback or dogleg access ramps and stairs shall be continuous between runs or flights.

**4. Extensions**

- Access ramp handrails shall extend horizontally above the landing for 12 inches minimum beyond the top and bottom of ramp runs.
- At the top of a stair flight, handrails shall extend horizontally above the landing for 12 inches minimum beginning directly above the first riser nosing.

- At the bottom of a stair flight, handrails shall extend at the slope of the stair flight for a horizontal distance at least equal to one tread depth beyond the last riser nosing.
- Handrail extensions shall return to a wall, guard, or the landing surface, or shall be continuous to the handrail of an adjacent access ramp run or stair flight.

**Exception:** Handrail extensions shall not be required for continuous handrails at the inside turn of switchback or dogleg access ramps or stairs.

#### **1510.15(4) Other Pedestrian Facilities, Features, and Elements**

This chapter covers the accessibility criteria for the most commonly encountered pedestrian design elements in the public right of way. However, there are ADA requirements that apply to any feature or element for pedestrian use, such as doorways, elevators, stairs, call boxes, and drinking fountains. For accessibility criteria for less commonly encountered pedestrian design elements, consult the applicable federal guidance document(s) listed in [1510.02\(2\)](#).

#### **1510.16 Illumination and Signing**

In Washington State, the highest number of collisions between vehicles and pedestrians tends to occur during November through February, when there is poor visibility and fewer daylight hours. Illumination of pedestrian crossings and other walkways is an important design consideration because lighting has a major impact on a pedestrian's safety and sense of security. Illumination provided solely for vehicular traffic is not always effective in lighting parallel walkways for pedestrians. Consider pedestrian-level (mounted at a lower level) lighting for pedestrian circulation paths, intersections, and other pedestrian crossing areas with high nighttime pedestrian activity, such as shopping districts, transit stops, schools, community centers, and other major pedestrian generators or areas with a history of pedestrian collisions. (See [Chapter 1040](#) for design guidance on illumination, and [Chapter 1020](#) and the [MUTCD](#) for pedestrian-related signing.)

#### **1510.17 Work Zone Pedestrian Accommodation**

While Title II of the ADA requires that a public entity maintain its pedestrian facilities in operable working condition, including maintenance of their accessibility features, construction and maintenance activities often temporarily disrupt these facilities. When this occurs, provide access and mobility for pedestrians through and around work zones (see [Exhibit 1510-31](#)). Address this in the temporary traffic control plans if the project occurs in a location accessible to pedestrians. The designer must determine pedestrian needs in the proposed work zone during the public input process and through field visits.

Detailed guidance on work zone pedestrian accommodation can be found in the *WSDOT Field Guide for Accessible Public Rights of Way*, the [MUTCD](#), and [Chapter 1010](#).

Some work zone considerations include:

- Separate pedestrians from conflicts with work zone equipment and operations.
- Separate pedestrians from traffic moving through or around the work zone.
- Provide pedestrians with alternate routes that have accessible and convenient travel paths that duplicate, as closely as feasible, the characteristics of the existing pedestrian facilities.

Provide walkways that are clearly marked and pedestrian barriers that are continuous, rigid, and detectable to vision-impaired persons who navigate with a cane. Also, keep:

- The pedestrian head space clear.
- Walkways free from pedestrian hazards such as holes, debris, and abrupt changes in grade or terrain.
- Access along sidewalks clear of obstructions such as construction traffic control signs.
- A minimum clear width path throughout: 4 feet for pedestrians or 10 feet for pedestrians and bicyclists.

Temporary pedestrian facilities within the work zone must meet accessibility criteria to the maximum extent feasible. (See [1510.06](#) and [1510.07](#) for pedestrian circulation path and pedestrian access route accessibility criteria.)

Consider the use of flaggers if pedestrian generators such as schools are in the work zone vicinity. Consider spotters who are prepared to help pedestrians through the work zone.

Provide for advance public notification of sidewalk closures in the contract special provisions and plans.

Where transit stops are affected or relocated because of work activity, provide an accessible route to temporary transit stops.



Meets ADA requirements



Does not meet ADA requirements

### Work Zones and Pedestrian Facilities *Exhibit 1510-31*

## 1510.18 Documentation

Refer to [Chapter 300](#) for design documentation requirements.

Traffic Volume (ADT)	Posted Speed	Roadway Type			
		2 lanes	2 lanes, raised median <sup>[1]</sup>	4 lanes, raised median <sup>[1]</sup>	6 lanes, raised median <sup>[1]</sup>
Less than or equal to 9,000	30 mph and lower	Marked crosswalk	Marked crosswalk	Additional enhancement	
	35 mph to 40 mph	Marked crosswalk	Marked crosswalk	Additional enhancement	
	45 mph and higher	Additional enhancement	Additional enhancement	Active enhancement	
9,000 to 15,000	30 mph and lower	Marked crosswalk	Marked crosswalk	Additional enhancement	
	35 mph to 40 mph	Marked crosswalk	Marked crosswalk	Additional enhancement	
	45 mph and higher	Additional enhancement	Additional enhancement	Active enhancement	
15,000 to 30,000	30 mph and lower	Additional <sup>[2]</sup> enhancement	Additional enhancement	Additional <sup>[2]</sup> enhancement	Active <sup>[4]</sup> enhancement
	35 mph to 40 mph	Additional <sup>[2]</sup> enhancement	Additional enhancement	Active enhancement	Active <sup>[4]</sup> enhancement
	45 mph and higher	Active enhancement	Active enhancement	See note [3]	See note [3]
Greater than 30,000	45 mph and lower	Active enhancement	Active enhancement	Pedestrian <sup>[5]</sup> traffic signal	Pedestrian <sup>[5]</sup> traffic signal

Inside city limits where the population exceeds 25,000, coordinate the decision to mark crosswalks with the city. Provide documentation for all marked crosswalks.

For additional considerations that may be appropriate based on site-specific engineering analyses, see [1510.10](#).

**Notes:**

- [1] Raised median/traffic island with a cut-through path minimum width of 5 feet and a median width of 6 feet.
- [2] Consider active enhancement treatment for roadways exceeding 20,000 ADT.
- [3] Provide alternate routes for pedestrian crossings, or construct a grade-separated facility.
- [4] Location may be approaching the need for a controlled crossing. A pedestrian signal may be appropriate, based on engineering analysis.
- [5] Consult with the region Traffic Engineer for determination of level of enhancement and approval.

**Minimum Guidelines (additive for each level):**

**“Marked crosswalk”**

- Marking and signing in accordance w/[MUTCD](#)
- Pedestrian perspective warning signs
- Illumination (see [Chapter 1040](#))

**“Additional enhancement”**

- Minimum guidelines listed under “Marked crosswalk”
- Stop or yield line in accordance w/[MUTCD](#)
- Advance signing in accordance w/[MUTCD](#)

**“Active enhancement”<sup>[5]</sup>**

- Minimum guidelines listed under “Additional enhancement”
- Raised median/traffic island
- Pedestrian-actuated flashing beacons for roadway with 4 or more lanes

**Crosswalk Marking and Enhancement Guidelines**  
*Exhibit 1510-32*

- 1600.01 [General](#)
- 1600.02 [References](#)
- 1600.03 [Clear Zone](#)
- 1600.04 [Mitigation Guidance](#)
- 1600.05 [Medians](#)
- 1600.06 [Other Roadside Safety Features](#)
- 1600.07 [Documentation](#)

## 1600.01 General

Roadside safety addresses the area outside the roadway and is an important component of total highway design. There are numerous reasons why a vehicle leaves the roadway, including driver error and behaviors. Regardless of the reason, a roadside design can reduce the seriousness of the error and the subsequent consequences of a roadside encroachment. From a crash reduction and severity perspective, the ideal highway has roadsides and median areas that are flat and unobstructed by objects. It is also recognized that different facilities have different needs and considerations, and these issues are considered in any final design.

It is not possible to provide a clear zone free of objects at all locations and under all circumstances. The engineer faces many tradeoffs in design decision-making, balancing needs of the environment, right of way, and different modes of transportation. The fact that recommended values for guardrail are presented in this chapter does not require the Department to modify all locations to meet the specified criteria; those locations are addressed as appropriate through the priority array.

Elements such as sideslopes, fixed objects, and water are features that a vehicle might encounter when it leaves the roadway. These features present varying degrees of deceleration to the vehicle and its occupants. Unfortunately, geography and economics do not always allow ideal highway conditions. The mitigative measures to be taken depend on the probability of a collision occurring, the likely severity, and the available resources.

In order of priority, the mitigative measures the Washington State Department of Transportation (WSDOT) uses are:

1. Removal
2. Relocation
3. Reduction of impact severity (using breakaway features or making it traversable) and
4. Shielding with a traffic barrier.

Factors for selecting a mitigative measure include, but may not be limited to:

- Cost (initial and life cycle costs)
- Maintenance needs
- Collision severity

Use traffic barriers when other measures cannot reasonably be accomplished and conditions are appropriate based on engineering analysis. (See [Chapter 1610](#) for additional information on traffic barriers.)

## 1600.02 References

### 1600.02(1) Federal/State Laws and Codes

[Revised Code of Washington \(RCW\) 47.24.020\(2\)](#), Jurisdiction, control

[RCW 47.32.130](#), Dangerous objects and structures as nuisances

### 1600.02(2) Design Guidance

*Highway Safety Manual*, AASHTO

*Local Agency Guidelines* (City and County Design Standards), M 36-63, WSDOT

*Roadside Design Guide*, AASHTO, 2011

*Standard Plans for Road, Bridge, and Municipal Construction (Standard Plans)*, M 21-01, WSDOT

### 1600.02(3) Supporting Information

*A Policy on Geometric Design of Highways and Streets (Green Book)*, AASHTO, 2011

*Understanding Design Clear Zone* – This e-learning course for WSDOT employees covers how to determine the appropriate Design Clear Zone for recoverable and nonrecoverable slopes as well as ditches. Request this training via the web-based Learning Management System.

*Highways Over National Forest Lands*, MOU, 2013, US Forest Service and WSDOT,  
[www.wsdot.wa.gov/publications/manuals/m22-50.htm](http://www.wsdot.wa.gov/publications/manuals/m22-50.htm)

*Utilities Manual*, M 22-87, WSDOT. Chapter 9 provides guidance for utilities in the WSDOT right of way.

## 1600.03 Clear Zone

A clear roadside border area is a primary consideration when analyzing potential roadside and median features (as defined in [1600.04](#)). The intent is to provide as much clear, traversable area for a vehicle to recover as practicable given the function of the roadway and the potential tradeoffs. The Design Clear Zone is used to evaluate the adequacy of the existing clear area and proposed modifications of the roadside. When considering the placement of new objects along the roadside or median, evaluate the potential for impacts and try to select locations with the least likelihood of an impact by an errant vehicle.

In situations where the Design Clear Zone is beyond WSDOT right of way, evaluate options on a case-by-case basis. Consider the nature of the objects within the Design Clear Zone, the roadway geometry, traffic volume, and crash history. Coordinate with adjacent property owners when proposed options include any work beyond WSDOT right of way. At a minimum, provide clear zone to the limits of the WSDOT right of way.

### 1600.03(1) Design Clear Zone on Limited Access State Highways and Other State Highways Outside Incorporated Cities and Towns

Evaluate the Design Clear Zone when the Clear Zone column on the design matrices (see [Chapter 1100](#)) indicates Full Design Level (F) or when considering the placement of a new fixed object on the roadside or median. Use the Design Clear Zone Inventory form ([Exhibit 1600-3](#)) to identify potential features to be mitigated and propose corrective actions.



Guidance for establishing the Design Clear Zone for highways outside incorporated cities is provided in [Exhibit 1600-2](#). This guidance also applies to limited access facilities within the city limits. Providing a clear recovery area that is consistent with this guidance does not require any additional documentation. However, there might be situations where it is not practicable to provide these recommended distances. In these situations, document the decision as a deviation as discussed in [Chapter 300](#).

For additional Design Clear Zone guidance relating to roundabouts, see [Chapter 1320](#).

For state highways that are in an urban environment, but outside an incorporated city, evaluate both median and roadside clear zones as discussed above using [Exhibit 1600-2](#). However, there is flexibility in establishing the Design Clear Zone in urbanized areas adjacent to incorporated cities and towns. To achieve this flexibility, an evaluation of the impacts, including safety, aesthetics, the environment, economics, modal needs, and access control, can be used to establish the Design Clear Zone. This discussion, analysis, and legal agreement development takes place early in the consideration of the median and roadside designs. A legal agreement on the responsibility for design, construction, operation, and maintenance for these median and roadside sections must be formalized with the city and/or county. Justify the design decision for the selected Design Clear Zone as part of the design approval or a project or corridor analysis (see [Chapter 300](#)).

Because AASHTO's *A Policy on Geometric Design of Highways and Streets* had addressed the concept of operational offset within the discussion of clear zone, some practitioners misinterpreted this offset as providing an adequate clear zone. The 18-inch operational offset beyond the face of curb is a lateral clearance for opening car doors or for truck mirrors.

### 1600.03(2) Design Clear Zone Inside Incorporated Cities and Towns

For managed access state highways within an urban area, it might not be practicable to provide the Design Clear Zone distances shown in [Exhibit 1600-2](#). Roadways within an urban area generally have curbs and sidewalks and might have objects such as trees, poles, benches, trash cans, landscaping, and transit shelters along the roadside.

For projects on city streets as state highways that include work in those areas that are the City's responsibility and jurisdiction (see [Exhibit 1600-1](#)), design the project using the city's Development/Design Standards. The standards adopted by the city must meet the requirements set by the Design Standards Committee for all projects on arterials, bike projects, and all federal-aid projects.

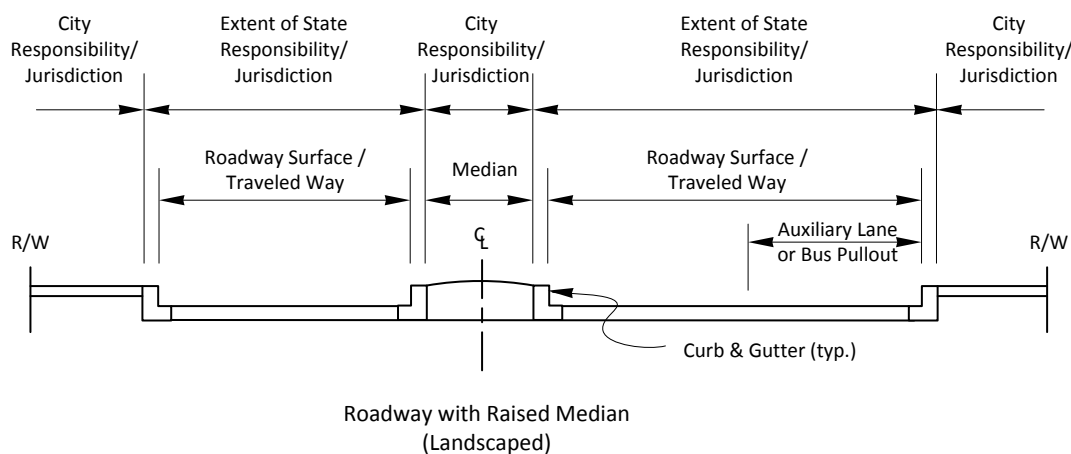

### City and State Responsibilities and Jurisdictions

Exhibit 1600-1

**1600.03(2)(a) Roadside and Median**

For managed access state highways inside incorporated cities, it is the city's responsibility to establish an appropriate Design Clear Zone in accordance with guidance contained in the City and County Design Standards (*Local Agency Guidelines*, Chapter 42.) [Exhibit 1600-1](#) shows an example of state and city responsibilities and jurisdictions. Document the Design Clear Zone established by the city in the Design Documentation Package. Have the responsible transportation official from the City (*e.g., City Engineer*) document the Design Clear Zone, and their acknowledgement and acceptance of the design and maintenance responsibilities for project roadsides and medians, in a letter addressed to WSDOT, and file this letter as part of the local agency coordination in the Design Documentation Package. Respond to the sender by letter acknowledging receipt. Sample templates for these letters will be made available online at the Design Support website under the Design Documentation section.

**1600.03(3) Design Clear Zone and Calculations**

The Design Clear Zone guidance provided in [Exhibit 1600-2](#) is a function of the posted speed, sideslope, and traffic volume. There are no distances in the table for 3H:1V fill slopes. Although fill slopes between 4H:1V and 3H:1V are considered traversable if free of fixed objects, these slopes are defined as nonrecoverable slopes. A vehicle might be able to begin recovery on the shoulder, but likely will not be able to further this recovery until reaching a flatter area (4H:1V or flatter) at the toe of the slope. Under these conditions, the Design Clear Zone distance is called a recovery area. The method used to calculate the recovery area and an example are shown in [Exhibit 1600-4](#).

For ditch sections, the following criteria determine the Design Clear Zone:

- (a) For ditch sections with foreslopes 4H:1V or flatter (see [Exhibit 1600-5](#), Case 1, for an example), the Design Clear Zone distance is the greater of the following:
- The Design Clear Zone distance for a 10H:1V cut section based on speed and the average daily traffic (ADT).
  - A horizontal distance of 5 feet beyond the beginning of the backslope.

When a backslope steeper than 3H:1V continues for a horizontal distance of 5 feet beyond the beginning of the backslope, it is not necessary to use the 10H:1V cut slope criteria.

- (b) For ditch sections with foreslopes steeper than 4H:1V and backslopes steeper than 3H:1V, the Design Clear Zone distance is 10 feet horizontal beyond the beginning of the backslope (see [Exhibit 1600-5](#), Case 2, for an example).
- (c) For ditch sections with foreslopes steeper than 4H:1V and backslopes 3H:1V or flatter, the Design Clear Zone distance is the distance established using the recovery area formula (see [Exhibit 1600-4](#); also see [Exhibit 1600-5](#), Case 3, for an example).

## 1600.04 Mitigation Guidance

There are three general categories of features to be mitigated: sideslopes, fixed objects, and water. This section provides guidance for determining when these objects present a significant risk to an errant motorist. For each case, the following conditions need added consideration:

- Locations with high expected collision frequency.
- Locations with pedestrian and bicycle usage. (See Chapters 1510, Pedestrian Design Considerations, 1515, Shared-Use Paths, and 1520, Roadway Bicycle Facilities.)
- Playgrounds, monuments, and other locations with high social or economic value.
- Redirectional land forms, also referred to as earth berms, were installed to mitigate objects located in depressed medians and at roadsides. They were constructed of materials that provided support for a traversing vehicle. With slopes in the range of 2H:1V to 3H:1V, they were intended to redirect errant vehicles. The use of redirectional land forms has been discontinued as a means for mitigating fixed objects. Where redirectional land forms currently exist as mitigation for a fixed object, provide designs where the feature they were intended to mitigate is removed, relocated, made crashworthy, or shielded with barrier. Landforms may be used to provide a smooth surface at the base of a rock cut slope.

The use of a traffic barrier for features other than those described below requires justification.

### 1600.04(1) Side Slopes

#### 1600.04(1)(a) Fill Slopes

Fill slopes can present a risk to an errant vehicle with the degree of severity dependent upon the slope and height of the fill. Providing fill slopes that are 4H:1V or flatter can mitigate this condition. If flattening the slope is not feasible or cost-effective, the installation of a barrier might be appropriate. [Exhibit 1600-6](#) represents a selection procedure used to determine whether a fill sideslope constitutes a condition for which a barrier is a cost-effective mitigation. The curves are based on the severity indexes and represent the points where total costs associated with a traffic barrier are equal to the predicted cost of collisions over the service life for selected slope heights without traffic barrier. If the ADT and height of fill intersect on the “Barrier Recommended” side of the embankment slope curve, then provide a barrier if flattening the slope is not feasible or cost-effective.

Do not use [Exhibit 1600-6](#) for slope design. Design slopes consistent with guidance in Chapters 1130 and 1230, evaluating designs with clear, traversable slopes before pursuing a barrier option. Also, if [Exhibit 1600-6](#) indicates that barrier is not recommended at an existing slope, that result is not justification for a deviation. For example, if the ADT is 4,000 and the embankment height is 10 feet, barrier might be cost-effective for a 2H:1V slope, but not for a 2.5H:1V slope. This process only addresses the potential risk of exposure to the slope. Obstacles on the slope can compound the condition. Where barrier is not cost-effective, use the recovery area formula to evaluate fixed objects on critical fill slopes less than 10 feet high.

#### 1600.04(1)(b) Cut Slopes

A cut slope is usually less of a risk than a traffic barrier. The exception is a rock cut with a rough face that might cause vehicle snagging rather than providing relatively smooth redirection.

Analyze the potential motorist risk and the benefits of treatment of rough rock cuts located within the Design Clear Zone. Conduct an individual investigation for each rock cut or group of rock cuts. A cost-effectiveness analysis that considers the consequences of doing nothing, removal, smoothing of the cut slope, and other viable options to reduce the severity of the condition can be used to determine the appropriate treatment. Some potential options are:

- Graded landform along the base of a rock cut.
- Flexible barrier
- More rigid barrier
- Rumble strips

#### **1600.04(2) Fixed Objects**

Use engineering judgment when considering the following objects for mitigation:

- Wooden poles or posts with cross-sectional areas greater than 16 square inches that do not have breakaway features.
- Signs, illumination, cameras, weather stations, and other items mounted on nonbreakaway poles, cantilevers, or bridges.
- Trees with a diameter of 4 inches or more, measured at 6 inches above the ground surface.
- Fixed objects extending above the ground surface by more than 4 inches; for example, boulders, concrete bridge rails, signal/electrical/ITS cabinets, piers, and retaining walls.
- Drainage items such as culvert and pipe ends.

Mitigate fixed features that exist within the Design Clear Zone when practicable. Although limited in application, there may be situations where removal of an object outside the right of way is appropriate. The possible mitigative measures are listed as follows in order of preference:

- Remove
- Relocate
- Reduce impact severity (using a breakaway feature)
- Shield the object by using longitudinal barrier or impact attenuator

#### **1600.04(2)(a) Trees**

When evaluating new plantings or existing trees, consider the maximum allowable diameter of 4 inches, measured at 6 inches above the ground when the tree has matured. When removing trees within the Design Clear Zone, complete removal of stumps is preferred. However, to avoid significant disturbance of the roadside vegetation, larger stumps may be mitigated by grinding or cutting them flush to the ground and grading around them.

Removal of trees may be beneficial to reduce the impacts of driving errors, which result in angle crashes and roadside and clear zone encroachments. It is recognized that different facilities have different needs and considerations, and these issues are considered in any final design. For instance, removal of trees within the Design Clear Zone may not be desirable in contexts such as within a forest, park, or within a scenic and recreational highway. In these corridors, analyze collision reports' contributing factors to determine whether roadside vegetation is contributing to collisions. If large vegetation is removed, replace with shrubs or groundcover or consult guidance contained in established vegetation management plans or corridor plans. Additional guidance for maintenance of roadside vegetation can be found in the Memorandum of Understanding between the US Forest Service and WSDOT, *Highways Over National Forest Lands*, dated July 2002.

**1600.04(2)(b) Mailboxes**

For mailboxes located within the Design Clear Zone, provide supports and connections as shown in the *Standard Plans*. The height from the ground to the bottom of the mailbox is 3 feet 3 inches. This height may vary from 3 feet 3 inches to 4 feet if requested by the mail carrier. If the desired height is to be different from 3 feet 3 inches, provide the specified height in the contract plans. (See [Exhibit 1600-7](#) for installation guidelines.) Coordinate with homeowners when upgrading mailboxes.

In urban areas where sidewalks are prevalent, contact the postal service to determine the most appropriate mailbox location. Locate mailboxes on limited access highways in accordance with [Chapter 530](#), Limited Access. A turnout, as shown in [Exhibit 1600-7](#), is not needed on limited access highways with shoulders of 6 feet or more where only one mailbox is to be installed. On managed access highways, mailboxes are to be on the right-hand side of the road in the postal carrier's direction of travel. Avoid placing mailboxes along high-speed, high-volume highways. Locate Neighborhood Delivery and Collection Box Units outside the Design Clear Zone.

**1600.04(2)(c) Culvert Ends**

Provide a traversable end treatment when the culvert end section or opening is on the roadway sideslope and within the Design Clear Zone. This can be accomplished for small culverts by beveling the end to match the sideslope, with a maximum of 4 inches extending out of the sideslope.

Bars might be needed to provide a traversable opening for larger culverts. Place bars in the plane of the culvert opening in accordance with the *Standard Plans* when:

- Single cross-culvert opening exceeds 40 inches, measured parallel to the direction of travel.
- Multiple cross-culvert openings that exceed 30 inches each, measured parallel to the direction of travel.
- Culvert approximately parallel to the roadway that has an opening exceeding 24 inches, measured perpendicular to the direction of travel.

Bars are permitted where they will not significantly affect the stream hydraulics and where debris drift is minor. Consult the region Maintenance Office to verify these conditions. If debris drift is a concern, consider options to reduce the amount of debris that can enter the pipe (see the *Hydraulics Manual*). Other treatments are extending the culvert to move the end outside the Design Clear Zone or installing a traffic barrier.

**1600.04(2)(d) Signposts**

Whenever possible, locate signs behind existing or planned traffic barrier installations to eliminate the need for breakaway posts. Place them at least 25 feet from the end of the barrier terminal and with the sign face behind the barrier. When barrier is not present, use terrain features to reduce the likelihood of an errant vehicle striking the signposts. Whenever possible, minor adjustments to the sign location may be made to take advantage of barrier or terrain features. (See [Chapter 1020](#) for additional information regarding the placement of signs.) Use the [MUTCD](#) to guide placement of the warning sign.

Signposts with cross-sectional areas greater than 16 square inches that are within the Design Clear Zone and not located behind a barrier are to have breakaway features as shown in the *Standard Plans*.

Sign bridges and cantilever sign supports are designed for placement outside the Design Clear Zone or shielded by barrier.

#### **1600.04(2)(e) Traffic Signal Standards/Posts/Supports**

Breakaway signal posts generally are not feasible or desirable. Since these supports are generally located at intersecting roadways, there is a higher potential for a falling support to impact vehicles and/or pedestrians. In addition, signal supports that have overhead masts may be too heavy for a breakaway design to work properly. Other mitigation, such as installing a traffic barrier, is also very difficult. With vehicles approaching the support from many different angles, a barrier would have to surround the support and would be subject to impacts at high angles. Additionally, barrier can inhibit pedestrian movements. Therefore, barrier is generally not an option. However, since speeds near signals are generally lower, the potential for a severe impact is reduced. For these reasons, locate the support as far from the traveled way as possible.

In locations where signals are used for ramp meters, the supports can be made breakaway as shown in the *Standard Plans*.

#### **1600.04(2)(f) Fire Hydrants**

Fire hydrants are allowed on WSDOT right of way by franchise or permit. Fire hydrants that are made of cast iron can be expected to fracture on impact and can therefore be considered a breakaway device. Any portion of the hydrant that will not be breakaway must not extend more than 4 inches above the ground. In addition, the hydrant must have a stem that will shut off water flow in the event of an impact. Mitigate other hydrant types.

#### **1600.04(2)(g) Utility Poles**

Since utilities often share the right of way, utility objects such as poles are often located along the roadside. It is undesirable/infeasible to install barrier for all of these objects, so mitigation is usually in the form of relocation (underground or to the edge of the right of way) or delineation. In some instances where there is a history of impacts with poles and relocation is not possible, a breakaway design might be appropriate. Evaluate roadway geometry and crash history as an aid in determining locations that exhibit the greatest need.

Contact the Headquarters (HQ) Design Office for information on breakaway features. Coordinate with the HQ Utilities Unit when appropriate.

Document coordination with the region Utilities Office for evaluations and mitigative measures. For additional guidance, see Chapter 9 of the *Utilities Manual*.

#### **1600.04(2)(h) Light Standards**

Provide breakaway light standards unless fixed light standards can be justified. Fixed light standards may be appropriate in areas of extensive pedestrian concentrations, such as adjacent to bus shelters. Document the decision to use fixed bases in the Design Documentation Package.

#### **1600.04(3) Water**

Water with a depth of 2 feet or more and located with a likelihood of encroachment by an errant vehicle is to be considered for mitigation on a project-by-project basis. Consider the length of time traffic is exposed to this feature.

Analyze the potential risk to motorists and the benefits of treating bodies of water located within the Design Clear Zone. A cost-effectiveness analysis that considers the consequences of doing nothing versus installing a longitudinal barrier can be used to determine the appropriate treatment.

For fencing considerations along water features, see [Chapter 560](#).

## **1600.05 Medians**

Medians are to be analyzed for the potential of an errant vehicle to cross the median and encounter oncoming traffic. Median barriers are normally used on limited access, multilane, high-speed, high-volume highways. These highways generally have posted speeds of 45 mph or higher. Median barrier is not normally placed on collectors or other state highways that do not have limited access control. Providing access through median barrier results in openings; therefore, end-treatments are needed.

Provide median barrier on full access control multilane highways with median widths of 50 feet or less and posted speeds of 45 mph or higher. Consider median barrier on highways with wider medians or lower posted speeds when there is a history of cross-median collisions.

When installing a median barrier, provide left-side shoulder widths as shown in Chapters [1130](#) and [1140](#) and shy distance as shown in [Chapter 1610](#). Consider a wider shoulder area where the barrier might cast a shadow on the roadway and hinder the melting of ice. (See [Chapter 1230](#) for additional criteria for placement of median barrier, [Chapter 1610](#) for information on the types of barriers that can be used, and [Chapter 1260](#) for lateral clearance on the inside of a curve to provide the needed stopping sight distance.) Consideration of drainage is an important factor when designing median barrier treatments.

When median barrier is being placed in an existing median, identify the existing crossovers and enforcement observation points. Provide the needed median crossovers in accordance with [Chapter 1370](#), considering enforcement needs. [Chapter 1410](#) provides guidance on HOV enforcement.

## **1600.06 Other Roadside Safety Features**

### **1600.06(1) Rumble Strips**

Rumble strips are grooves or rows of raised pavement markers placed perpendicular to the direction of travel to alert inattentive drivers. There are three kinds of rumble strips: roadway, shoulder, and centerline.

In Washington, most rumble strips consist of grooves milled into the pavement surface. Although most installations have not adversely affected the pavement, there have been a few instances where milled rumble strips have been associated with advanced levels of pavement deterioration, resulting in continuous ruts or large areas of pavement delamination. Poor pavement performance has most commonly been associated with rumble strip installations in bituminous surface treatment (BST) pavement and hot mix asphalt (HMA) pavement with low density, particularly along longitudinal joints. Rumble strip installation should be avoided in open-graded pavements. Consult with the Region Materials Engineer to provide adequate pavement structure and thickness for all proposed rumble strip locations. Additionally, there are some specific surface preparation requirements for areas to be resurfaced where rumble strips currently exist. In many instances, it is necessary to remove and inlay the existing rumble strips prior to resurfacing. For additional guidance on surface preparation and pavement stability, refer to WSDOT's Pavement Policy: <http://www.wsdot.wa.gov/maintops/mats/pavementguide.htm>

### 1600.06(1)(a) Roadway Rumble Strips

Roadway rumble strips are placed transversely to the traveled way to alert drivers who are approaching a change of roadway condition or object that requires substantial speed reduction or other maneuvering. Some locations where roadway rumble strips may be used are in advance of:

- Stop-controlled intersections.
- Port of entry/customs stations.
- Lane reductions where collision history shows a pattern of driver inattention.
- Horizontal alignment changes where collision history shows a pattern of driver inattention.

They may also be placed at locations where the character of the roadway changes, such as at the end of a freeway.

Contact the HQ Design Office for additional guidance on the design and placement of roadway rumble strips.

Document decisions to use roadway rumble strips in the Design Documentation Package.

### 1600.06(1)(b) Shoulder Rumble Strips

Shoulder rumble strips (SRS) are placed parallel to the traveled way just beyond the edge line to warn drivers they are entering a part of the roadway not intended for routine traffic use. Shoulder rumble strips are effective in reducing run-off-the-road collisions when the contributing circumstances are human factors related, such as inattention, apparently fatigued, or apparently asleep.

When shoulder rumble strips are used, discontinue them where no edge stripe is present, such as at intersections and where curb and gutter are present. Discontinue shoulder rumble strips where shoulder driving is allowed. Where bicycle travel is allowed, discontinue shoulder rumble strips at locations where shoulder width reductions can cause bicyclists to move into or across the area where rumble strips would normally be placed, such as shoulders adjacent to bridges or longitudinal barrier with reduced shoulder widths.

Shoulder rumble strip patterns vary depending on the likelihood of bicyclists being present along the highway shoulder and whether they are placed on divided or undivided highways. Rumble strip patterns for undivided highways are shallower and may be narrower than patterns used on divided highways. They also provide gaps in the pattern, providing opportunities for bicycles to move across the pattern without having to ride across the grooves. There are four shoulder rumble strip patterns. Consult the [Standard Plans](#) for the patterns and construction details.

#### 1. Divided Highways

Install shoulder rumble strips on both the right and left shoulders of rural Interstate highways. Consider them on both shoulders of rural divided highways. Use the Shoulder Rumble Strip Type 1 pattern on divided highways.

Omitting shoulder rumble strips on rural Interstate highways is a design exception (DE) under any of the following conditions:

- When another project scheduled within two years of the proposed project will overlay or reconstruct the shoulders or will use the shoulders for detours.
- When a pavement analysis determines that installing shoulder rumble strips will result in inadequate shoulder strength.



- When overall shoulder width will be less than 4 feet wide on the left and 6 feet wide on the right.

## 2. Undivided Highways

Shoulder rumble strip usage on the shoulders of undivided highways demands strategic application because bicycle usage is more prevalent along the shoulders of the undivided highway system. Rumble strips affect the comfort and control of bicycle riders; consequently, their use is to be limited to highway corridors that experience high levels of run-off-the-road collisions. Apply the following criteria in evaluating the appropriateness of rumble strips on the shoulders of undivided highways.

- Consult the region and Headquarters Bicycle and Pedestrian Coordinators to determine bicycle usage along a route, and involve them in the decision-making process when considering rumble strips along bike touring routes or other routes where bicycle events are regularly held.
- Use on rural roads only.
- Determine that shoulder pavement is structurally adequate to support milled rumble strips.
- Posted speed is 45 mph or higher.
- Provide for at least 4 feet of usable shoulder between the rumble strip and the outside edge of shoulder. If guardrail or barrier is present, increase the dimension to 5 feet of usable shoulder. Field-verify these dimensions.
- Preliminary evaluation indicates a run-off-the-road collision experience of approximately 0.6 crashes per mile per year. (This value is intended to provide relative comparison of crash experience and is not to be used as absolute guidance on whether rumble strips are appropriate.)
- Do not place shoulder rumble strips on downhill grades exceeding 4% for more than 500 feet in length along routes where bicyclists are frequently present.
- An engineering analysis indicates a run-off-the-road collision experience considered correctable by shoulder rumble strips.

For projects that will remove and potentially replace existing shoulder rumble strips, evaluate the criteria for shoulder width and downhill grades for compliance with placement guidance. Discontinue rumble strips where the downhill grade exceeds 4% for more than 500 feet. If the usable shoulder width between the rumble strip and outer edge of shoulder is less than 4 feet (5 feet if guardrail or barrier is present) reevaluate the appropriateness of the rumble strips. Assess the existing shoulder rumble strip's impact on run-off-the-road crash experience and bicycling. Assess alternate rumble strip patterns and placement options. Consult the region and Headquarters Bicycle and Pedestrian Coordinators. Document decisions to continue or discontinue shoulder rumble strip usage where the existing usable shoulder width between the rumble strip and outer edge of shoulder is less than 4 feet (5 feet if guardrail or barrier is present).

Consult with the region or Headquarters Bicycle and Pedestrian Coordinator for determining levels of bicycle traffic for your project. The Shoulder Rumble Strip Type 2 or Type 3 pattern is used on highways with minimal bicycle traffic. When bicycle traffic on the shoulder is determined to be high, the Shoulder Rumble Strip Type 4 pattern is used.

Shoulder rumble strip installation considered at any other locations must involve the region and Headquarters Bicycle and Pedestrian Coordinators as a partner in the decision-making process.

Consult the following website for guidance on conducting an engineering analysis:

[www.wsdot.wa.gov/design/policy/roadsidesafety.htm](http://www.wsdot.wa.gov/design/policy/roadsidesafety.htm)

### **1600.06(1)(c) Centerline Rumble Strips**

Centerline rumble strips are placed on the centerline of undivided highways to alert drivers that they are entering the opposing lane. They are applied as a countermeasure for crossover collisions. Centerline rumble strips are installed with no differentiation between passing permitted and no passing areas. Refresh pavement markings when removed by centerline rumble strips.

A March 2011 WSDOT study found that centerline rumble strips were highly effective across the state highway network, and most effective on roadways where: the AADT is less than 8,000, the combined paved lane and shoulder width is 12 to 17 feet, and the posted speed is 45 to 55 mph.

Centerline rumble strips are evaluated using a programmatic approach, starting with a preliminary review of each rural undivided highway as a potential installation site. The HQ Design Office conducts the preliminary review, evaluating cross-centerline crash history and pavement width. A list of sites is generated from this review and periodically updated and distributed to the regions for a more detailed analysis of each site. The presence of a particular site on the preliminary list does not imply that rumble strips must be installed.

The preliminary review conducted in the Design Office does not assess pavement structure; traffic volume and composition; type and volume of nonmotorized users; or proximity to roadside residents. Region project development staff are expected to evaluate these items, and to field-verify roadway widths and appropriate project limits. The final determination about the appropriateness of centerline rumble strips is the responsibility of region project development staff. Although these decisions are made in the region, it is important that they be evaluated in a consistent manner from region to region. Evaluate the following criteria in determining the appropriateness of centerline rumble strips.

#### **1. Crash Experience**

WSDOT has evaluated the effectiveness of centerline rumble strips on roadways with various lane and shoulder widths. For roadways with a combined lane and shoulder width of 15 feet or more, the benefits are substantial. These highways exhibited a 50% reduction in fatal and serious injury crashes, when looking at both cross-centerline and run-off-the-road-right (ROTRR) crashes. For roadways with 12 to 14 feet of combined lane and shoulder width, the benefits are more closely aligned with reductions in cross-centerline crashes. There are mixed results with ROTRR crashes on 12- to 14-foot-wide roadways, although when combined with the cross-centerline crashes, the net result indicates an overall 25% reduction in fatal and serious injury crashes. Further evaluation of apparent run-off-the-road vehicles that cross the centerline and end on the opposing roadside may be of value.

Review the collision history to determine the frequency of collisions with human factors contributing circumstances such as inattention, apparently fatigued, apparently asleep, over the centerline, or on the wrong side of the road. These types of cross-centerline crashes are considered to be correctable with centerline rumble strips.

## 2. Highway Type

Centerline rumble strips are most appropriate on rural roads, but with special consideration, may also be appropriate for urban roads. Some concerns specific to urban areas are more residents impacted by noise in more densely populated areas, the frequent need to interrupt the rumble strip pattern to accommodate left-turning vehicles, and a reduced effectiveness at lower speeds (35 mph and below). Centerline rumble strips are not appropriate where two-way left-turn lanes exist.

## 3. Pavement Structure

Determine that the roadway pavement is structurally adequate to support milled rumble strips. Consult the Region Materials Engineer to verify that the pavement structure is adequate. When the rumble strip installation coincides with an HMA paving project, discuss options for pavement joint placement to determine if the rumble strips can be offset from the joint. WSDOT has experienced some pavement deterioration following the installation of rumble strips. Pay particular attention to the treatment of centerline rumble strips and recessed lane markers. Overlapping these grindings has resulted in some delaminated pavement. (See the [Standard Plans](#) for application guidance.)

## 4. Roadway Width

A 2004 study of the effects of centerline rumble strips on lateral placement and speed of vehicles determined that drivers tend to shift their lane position 3 to 5½ inches to the right to avoid driving on centerline rumble strips. This results in the vehicle driving closer to the pavement edge and to bicyclists who may be traveling on the outer edges of the lane. Centerline rumble strips are inappropriate when the combined lane and shoulder widths in either direction are less than 12 feet. (See Chapters 1130 and 1140 for guidance on lane and shoulder widths.)

The narrower roadways within this range warrant additional consideration. Where the combined lane and shoulder width is 14 feet or less, consider the level of bicycle and pedestrian use along the route. When drivers shift their lane position away from centerline to avoid the rumble strips, they are moving closer to pedestrians and bicyclists on the shoulder. Also consider the roadside characteristics and the potential for a lane position adjustment to result in a run-off-the-road event, evaluating clear zone width along the route. Balance these issues with the frequency and severity of cross-centerline crashes.

## 5. Traffic Volume

Higher-volume routes equate to greater exposure, with more opportunities for: cross-centerline crashes, conflicts with nonmotorized users on the shoulder, and incidental contact with the rumble strips. The March 2011 WSDOT centerline rumble strip study noted that lower-volume routes had higher rates of cross-centerline collisions.

## 6. Noise for Roadside Residents

Most rumble strip noise complaints result from incidental contact where the vehicle might not have been heading toward a crash. Left-turning or passing vehicles, along with the off-tracking of large trucks or trailers may result in incidental contact with centerline rumble strips. With some specific attention to details, some of these contacts can be significantly reduced by discontinuing the rumble strip installations through intersections or frequently used road approaches. For roadways with limited passing opportunities, evaluate the frequency and position of neighboring residents and site-specific crash experience to determine if the rumble strip should be discontinued in a potential passing location. Attention to horizontal curvature, curve widening, and large-vehicle usage may help identify locations where the rumble strips may need to be discontinued through a tight radius curve.

### 1600.06(2) Headlight Glare Considerations

Headlight glare from opposing traffic can cause potential safety problems. This can include glare from frontage roads. Glare can be reduced by the use of wide medians, separate alignments, earth mounds, plants, concrete barrier, and glare screens. Glare screen fencing may be effective for frontage roads. Consider long-term maintenance when selecting the treatment for glare. When considering glare screens, see [Chapter 1260](#) for lateral clearance on the inside of a curve to provide the necessary stopping sight distance. In addition to reducing glare, taller concrete barriers also provide improved crash performance for larger vehicles such as trucks.

Glare screen is relatively expensive, and its use is to be justified. It is difficult to justify the use of glare screen where the median width exceeds 20 feet, the ADT is less than 20,000 vehicles per day, or the roadway has continuous lighting. Consider the following factors when assessing the need for glare screen:

- Higher frequency of night collision compared to similar locations or statewide experience.
- Higher than normal ratio of night-to-day collisions.
- Unusual distribution or concentration of nighttime collisions.
- Over-representation of older drivers in night collisions.
- Combination of horizontal and vertical alignment, particularly where the roadway on the inside of a curve is higher than the roadway on the outside of the curve.
- Direct observation of glare.
- Public complaints concerning glare.

The most common area with the potential for glare is between opposing main line traffic. Other conditions for which glare screen might be appropriate are:

- Between a highway and an adjacent frontage road or parallel highway, especially where opposing headlights might seem to be on the wrong side of the driver.
- At an interchange where an on-ramp merges with a collector-distributor and the ramp traffic might be unable to distinguish between collector and main line traffic. In this instance, consider other solutions such as illumination.
- Where headlight glare is a distraction to adjacent property owners. Playgrounds, ball fields, and parks with frequent nighttime activities might benefit from screening if headlight glare interferes with these activities.

There are currently three basic types of glare screen available: chain link (see the [Standard Plans](#)), vertical blades, and concrete barrier (see [Exhibit 1600-8](#)).

When the glare is temporary (due to construction activity), consider traffic volumes, alignment, duration, presence of illumination, and type of construction activity. Glare screen may be used to reduce rubbernecking associated with construction activity, but less expensive methods, such as plywood that seals off the view of the construction area, might be more appropriate.

### **1600.07 Documentation**

Refer to [Chapter 300](#) for design documentation requirements.

Posted Speed (mph)	Average Daily Traffic	Cut Section (Backslope) (H:V)						Fill Section (H:V)					
		3:1	4:1	5:1	6:1	8:1	10:1	3:1	4:1	5:1	6:1	8:1	10:1
35 or Less		The Design Clear Zone Distance is 10 ft											
40	Under 250	10	10	10	10	10	10	*	13	12	11	11	10
	251 – 800	11	11	11	11	11	11	*	14	14	13	12	11
	801 – 2,000	12	12	12	12	12	12	*	16	15	14	13	12
	2,001 – 6,000	14	14	14	14	14	14	*	17	17	16	15	14
	Over 6,000	15	15	15	15	15	15	*	19	18	17	16	15
45	Under 250	11	11	11	11	11	11	*	16	14	13	12	11
	251 – 800	12	12	13	13	13	13	*	18	16	14	14	13
	801 – 2,000	13	13	14	14	14	14	*	20	17	16	15	14
	2,001 – 6,000	15	15	16	16	16	16	*	22	19	17	17	16
	Over 6,000	16	16	17	17	17	17	*	24	21	19	18	17
50	Under 250	11	12	13	13	13	13	*	19	16	15	13	13
	251 – 800	13	14	14	15	15	15	*	22	18	17	15	15
	801 – 2,000	14	15	16	17	17	17	*	24	20	18	17	17
	2,001 – 6,000	16	17	17	18	18	18	*	27	22	20	18	18
	Over 6,000	17	18	19	20	20	20	*	29	24	22	20	20
55	Under 250	12	14	15	16	16	17	*	25	21	19	17	17
	251 – 800	14	16	17	18	18	19	*	28	23	21	20	19
	801 – 2,000	15	17	19	20	20	21	*	31	26	23	22	21
	2,001 – 6,000	17	19	21	22	22	23	*	34	29	26	24	23
	Over 6,000	18	21	23	24	24	25	*	37	31	28	26	25
60	Under 250	13	16	17	18	19	19	*	30	25	23	21	20
	251 – 800	15	18	20	20	21	22	*	34	28	26	23	23
	801 – 2,000	17	20	22	22	23	24	*	37	31	28	26	25
	2,001 – 6,000	18	22	24	25	26	27	*	41	34	31	29	28
	Over 6,000	20	24	26	27	28	29	*	45	37	34	31	30
65	Under 250	15	18	19	20	21	21	*	33	27	25	23	22
	251 – 800	17	20	22	22	24	24	*	38	31	29	26	25
	801 – 2,000	19	22	24	25	26	27	*	41	34	31	29	28
	2,001 – 6,000	20	25	27	27	29	30	*	46	37	35	32	31
	Over 6,000	22	27	29	30	31	32	*	50	41	38	34	33
70	Under 250	16	19	21	21	23	23	*	36	29	27	25	24
	251 – 800	18	22	23	24	26	26	*	41	33	31	28	27
	801 – 2,000	20	24	26	27	28	29	*	45	37	34	31	30
	2,001 – 6,000	22	27	29	29	31	32	*	50	40	38	34	33
	Over 6,000	24	29	31	32	34	35	*	54	44	41	37	36

**Notes:**

This exhibit applies to:

- All state highways outside incorporated cities.
- Limited access state highways within cities.

For Roadside and Median areas on managed access state highways within incorporated cities, see [1600.03](#) for guidance. Curb is not considered adequate to redirect an errant vehicle.

Design Clear Zone distances are given in feet, measured from the edge of traveled way.

\*When the fill section slope is steeper than 4H:1V, but not steeper than 3H:1V, the Design Clear Zone distance is modified by the recovery area formula (see [Exhibit 1600-4](#)) and is referred to as the recovery area. The basic philosophy behind the recovery area formula is that the vehicle can traverse these slopes but cannot recover (control steering); therefore, the horizontal distance of these slopes is added to the Design Clear Zone distance to form the recovery area.

### Design Clear Zone Distance Table

*Exhibit 1600-2*



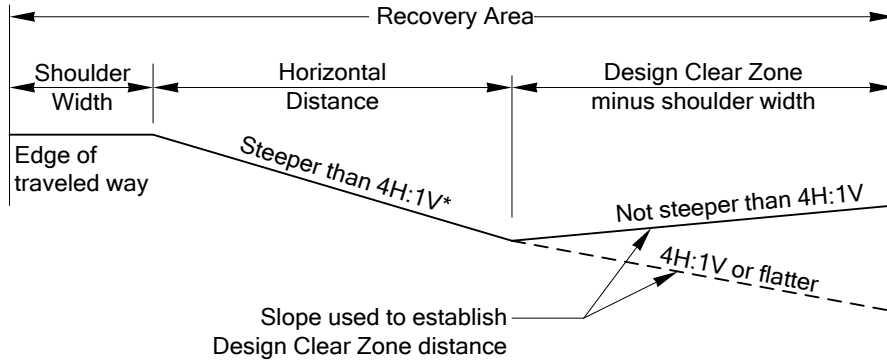

\*Recovery area normally applies to slopes steeper than 4H:1V, but not steeper than 3H:1V. For steeper slopes, the recovery area formula may be used as a guide if the embankment height is 10 ft or less.

**Formula:**

$$\text{Recovery area} = (\text{shoulder width}) + (\text{horizontal distance}) + (\text{Design Clear Zone distance} - \text{shoulder width})$$

**Example:**

Fill section (slope 3H:1V or steeper)

Conditions: Speed – 45 mph  
 Traffic – 3,000 ADT  
 Slope – 3H:1V

Criteria: Slope 3H:1V – Use recovery area formula

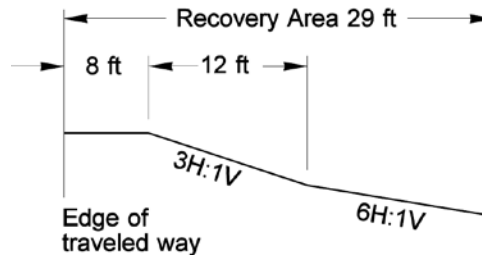

$$\begin{aligned} \text{Recovery area} &= (\text{shoulder width}) + (\text{horizontal distance}) \\ &+ (\text{Design Clear Zone distance} - \text{shoulder width}) \\ &= 8 + 12 + (17-8) \\ &= 29 \text{ feet} \end{aligned}$$

**Recovery Area**  
 Exhibit 1600-4



**Cut section with ditch (foreslope 4H:1V or flatter)**

Conditions: Speed – 55 mph  
 Traffic – 4,200 ADT  
 Slope – 4H:1V

Criteria: Greater of:

- (1) Design Clear Zone for 10H:1V cut section, 23 feet
- (2) 5 feet horizontal beyond beginning of backslope, 22 feet

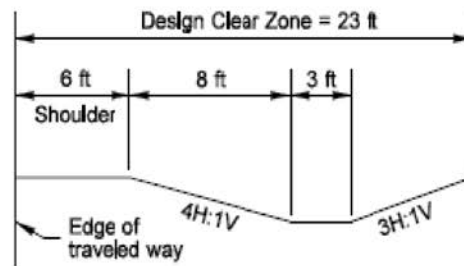

Design Clear Zone = 23 feet

**Case 1**

**Cut section with ditch (foreslope steeper than 4H:1V and backslope steeper than 3H:1V)**

Conditions: NA

Criteria: 10 feet horizontal beyond beginning of backslope

Design Clear Zone = 19 feet

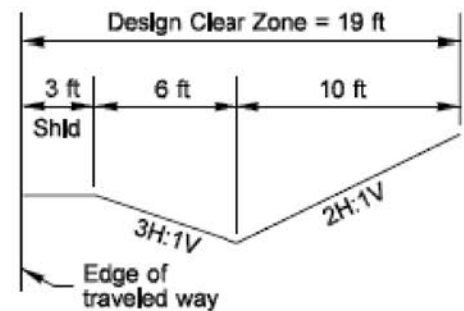

**Case 2**

**Cut section with ditch (foreslope 3H:1V or steeper and backslope not steeper than 3H:1V)**

Conditions: Speed – 45 mph  
 Traffic – 3,000 ADT  
 Foreslope – 2H:1V  
 Backslope – 4H:1V

Criteria: Use recovery area formula

$$\begin{aligned}
 \text{Recovery Area} &= (\text{shoulder width}) + (\text{horizontal distance}) \\
 &\quad + (\text{Design Clear Zone distance} \\
 &\quad - \text{shoulder width}) \\
 &= 6 + 6 + (15 - 6) \\
 &= 21 \text{ feet}
 \end{aligned}$$

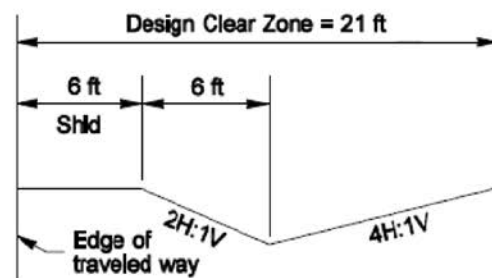

**Case 3**

**Design Clear Zone for Ditch Sections**

*Exhibit 1600-5*

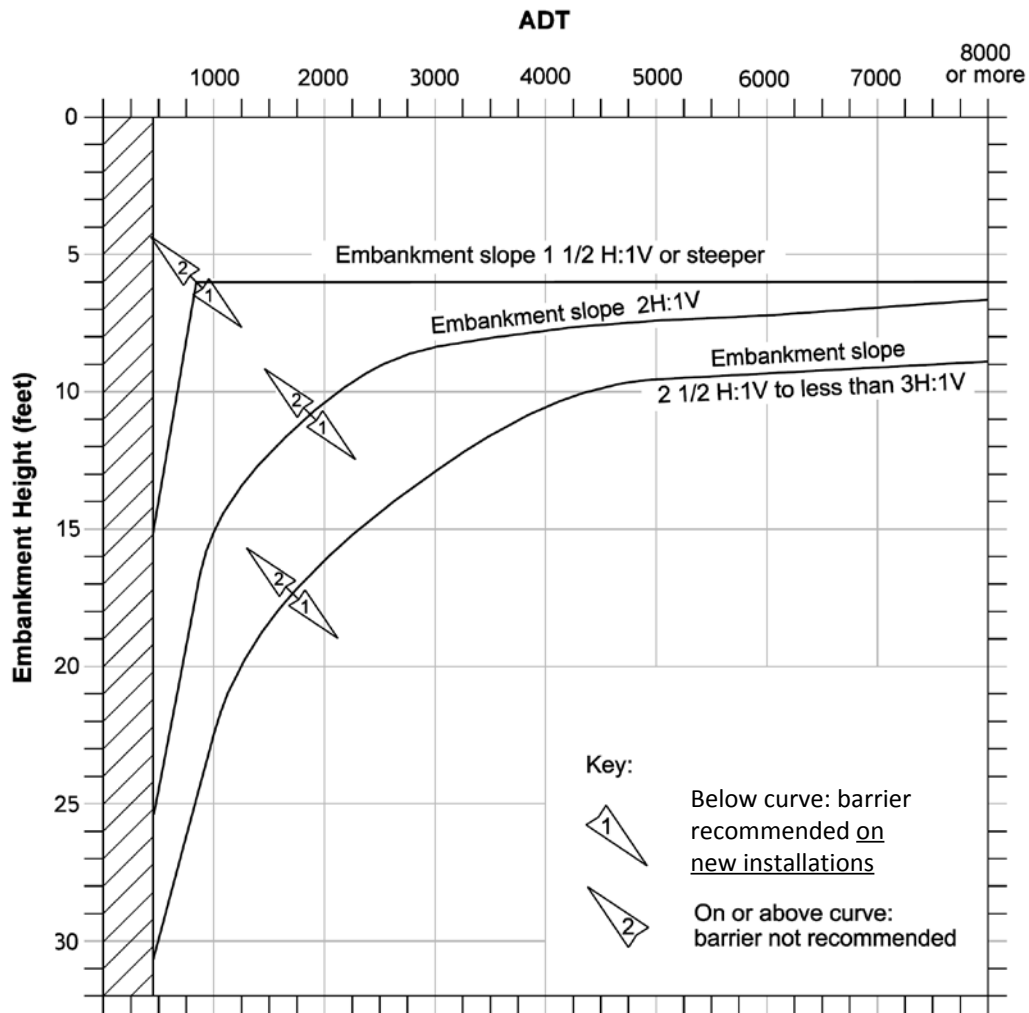

**Note:**

Routes with ADTs under 400 may be evaluated on a case-by-case basis.

**Guidelines for Embankment Barrier**  
*Exhibit 1600-6*

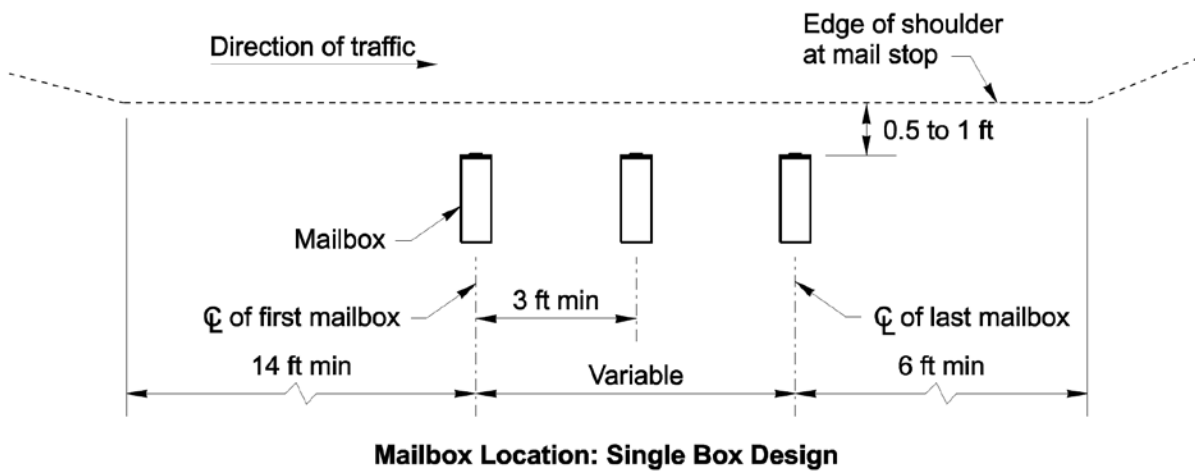
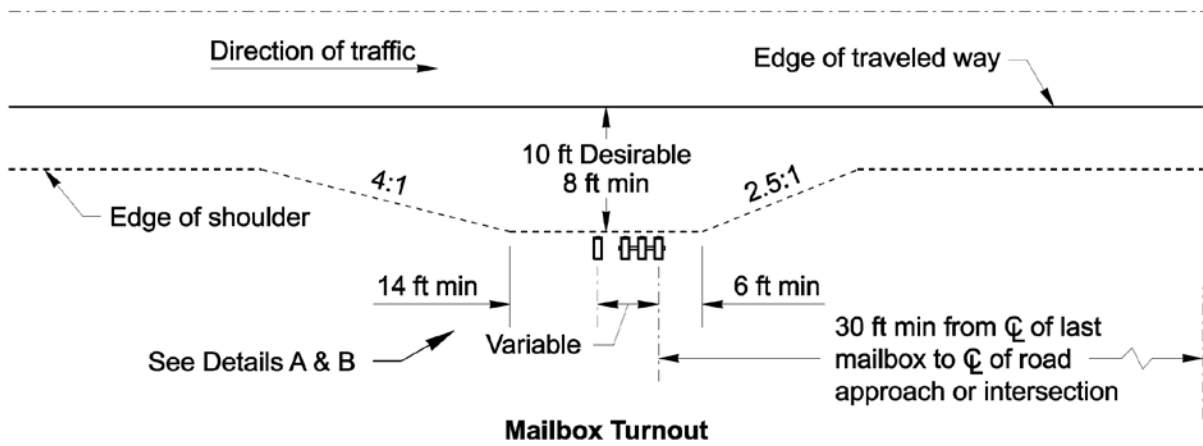

Detail A

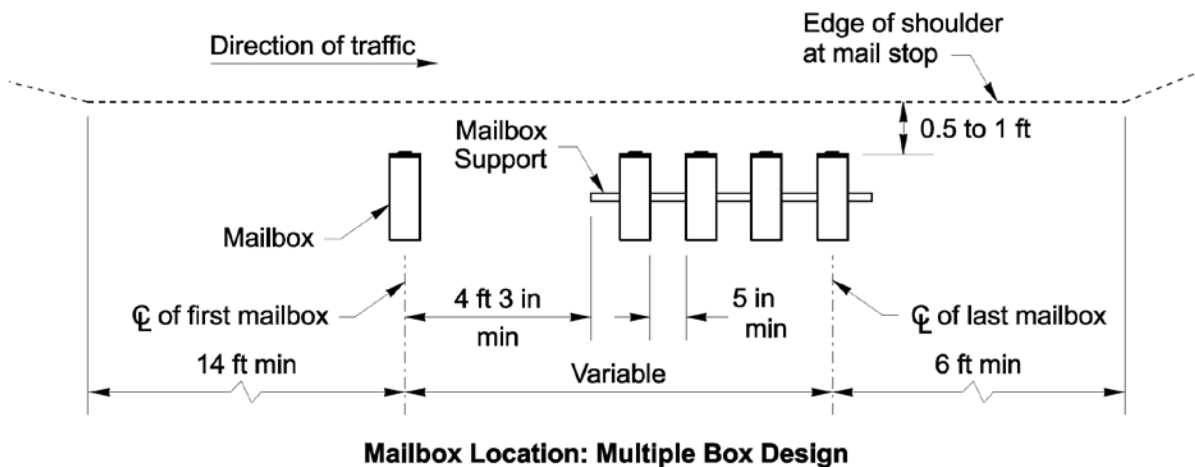

Detail B

**Mailbox Location and Turnout Design**

*Exhibit 1600-7*

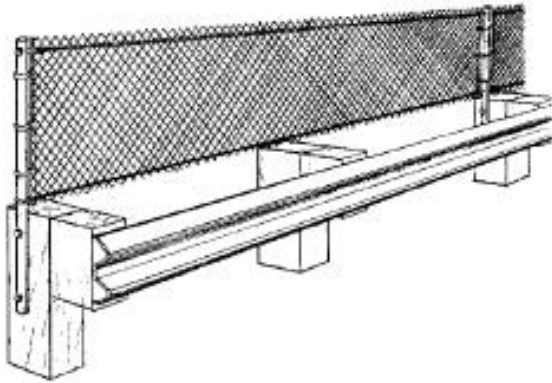

Chain Link

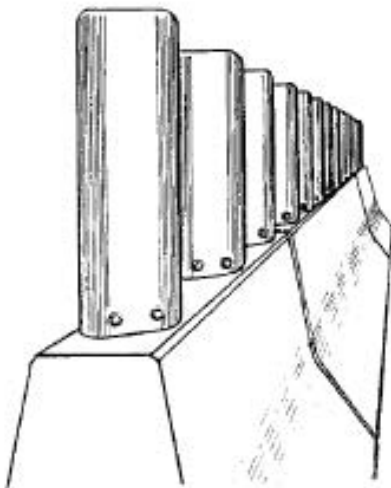
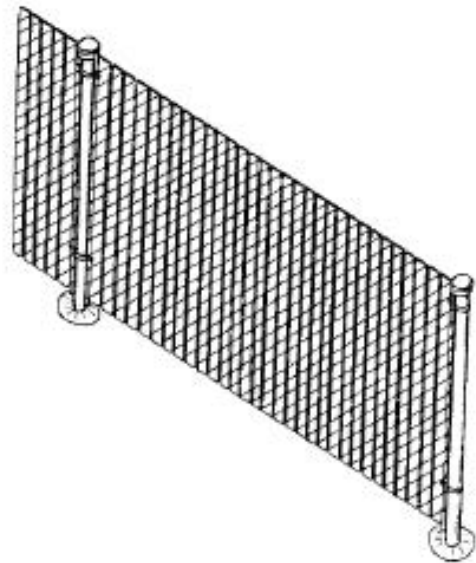

Vertical Blades

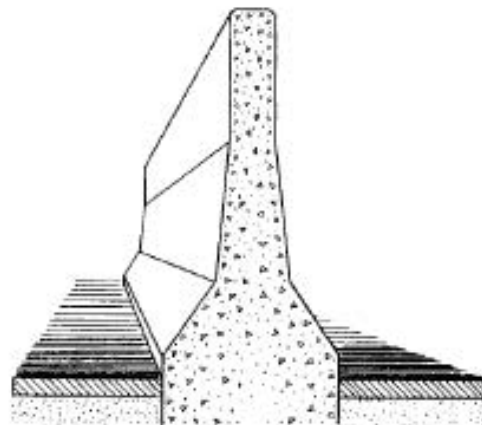

Concrete Barrier

**Glare Screens**  
*Exhibit 1600-8*

- 1610.01 General
- 1610.02 References
- 1610.03 Definitions
- 1610.04 Project Criteria
- 1610.05 Barrier Design
- 1610.06 Beam Guardrail
- 1610.07 Cable Barrier
- 1610.08 Concrete Barrier
- 1610.09 Special-Use Barriers
- 1610.10 Bridge Traffic Barriers
- 1610.11 Other Barriers
- 1610.12 Documentation

## 1610.01 General

The Washington State Department of Transportation (WSDOT) uses traffic barriers to reduce the overall severity of collisions that occur when a vehicle leaves the traveled way. Consider whether a barrier is preferable to the recovery area it replaces. In some cases, installation of a traffic barrier may result in more collisions, as it presents an object that can be struck. Barriers are designed so that such encounters might be less severe and not lead to secondary or tertiary collisions. However, when impacts occur, traffic barriers are not guaranteed to redirect vehicles without injury to the occupants or additional collisions.

Barrier performance is affected by the characteristics of the types of vehicles that collide with them. For example, motor vehicles with large tires and high centers of gravity are commonplace on our highways and they are designed to mount obstacles. Therefore, they are at greater risk of mounting barriers or of not being decelerated and redirected as conventional vehicles would be.

When barriers are crash-tested, it is impossible to replicate the innumerable variations in highway conditions. Therefore, barriers are crash-tested under standardized conditions. These standard conditions were previously documented in National Cooperative Highway Research Program (NCHRP) Report 350. These guidelines have been updated and are now presented in the *Manual for Assessing Safety Hardware* (MASH).

Barriers are not placed with the assumption that the system will restrain or redirect all vehicles in all conditions. It is recognized that the designer cannot design a system that is foolproof or will address every potential collision situation. Instead, barriers are placed with the assumption that, under normal conditions, they might provide lower potential for occupant deceleration and vehicle redirection for given roadside collisions when compared to a location without barrier.

Traffic barriers do not prevent collisions or injuries from occurring. They are intended to lower the potential severity for crash outcomes based on the conditions for which they are installed. Consequently, barriers should not be used unless a reduced crash frequency and severity potential is likely. No matter how well a barrier system is designed, optimal performance is dependent on drivers' proper use, maintenance, and operation of their vehicles and the proper use of vehicle restraint systems. At the time of installation, the ultimate choice of barrier type and placement is made by gaining an understanding of site and traffic conditions, having a thorough understanding of and using the criteria presented in Chapters 1600 and 1610, and using engineering judgment.

## 1610.02 References

### 1610.02(1) Design Guidance

*Bridge Design Manual*, M 23-50, WSDOT

*Roadside Design Guide*, AASHTO, 2011

*Standard Plans for Road, Bridge, and Municipal Construction (Standard Plans)*, M 21-01, WSDOT

*Traffic Manual*, M 51-02, WSDOT

### 1610.02(2) Supporting Information

NCHRP 350, TRB, 1993

*Manual for Assessing Safety Hardware (MASH)*, AASHTO, 2009

*Determining Length of Need*. This e-learning course for WSDOT employees covers the “Length of Need,” which is a calculation of how much longitudinal barrier is necessary to shield objects on the roadside. Request this training via the web-based Learning Management System.

## 1610.03 Definitions

Refer to the *Design Manual Glossary* for many of the terms used in this chapter.

## 1610.04 Project Criteria

Any project that introduces new barrier onto the roadside (including median) should be placed using full design level guidance (1610.04(2)(b)). This section identifies the barrier elements that are addressed according to notes in the Design Matrices in Chapter 1100. Remove barrier that is not needed. Use the criteria in [Chapter 1600](#) as the basis for removal.

### 1610.04(1) Barrier Terminals and Transitions

Install, replace, or upgrade transitions as discussed in [1610.06\(6\)](#), Transitions and Connections.

Impact attenuator criteria can be found in [Chapter 1620](#), Impact Attenuator Systems. Concrete barrier terminal criteria can be found in [1610.08\(3\)](#).

When installing new terminals, consider extending the guardrail to meet the length-of-need criteria found in [1610.05\(5\)](#) as a spot safety enhancement, which is a modification to isolated roadway or roadside features that, in the engineer’s judgment, reduce potential for collision frequency or severity.

When the end of a barrier has been terminated with a small mound of earth, remove and replace with a crash-tested terminal, except as noted in [1610.09](#).

Redirectional landforms, also referred to as earth berms, were formerly installed to help mitigate collisions with fixed objects located in depressed medians and at roadsides. They were constructed of materials that provided support for a traversing vehicle. With slopes in the range of 2H:1V to 3H:1V, they were intended to redirect errant vehicles. The use of redirection landforms has been discontinued. Where redirection landforms currently exist as mitigation for a fixed object, provide alternative means of mitigation of the fixed object, such as remove, relocate, upgrade with crash-tested systems, or shield with barrier. Landforms may be used to provide a smooth surface at the base of a rock cut slope.

Replace guardrail terminals that do not have a crash-tested design with crash-tested guardrail terminals (see 1610.06(5), Terminals and Anchors). Common features of systems that do not meet current crash-tested designs include:

- No cable anchor.
- A cable anchored into concrete in front of the first post.
- Second post not breakaway (CRT).
- Design A end section (Design C end sections may be left in place—see the *Standard Plans* for end section details).
- Terminals with beam guardrail on both sides of the posts (two-sided).
- Buried guardrail terminals that slope down such that the guardrail height is reduced to less than 26 inches.

When the height of an existing terminal will be reduced to less than 26 inches from the ground to the top of the rail element, adjust the height to a minimum of 26 inches and a maximum of 28 inches. A rail height of 28 inches is desirable to accommodate future overlays. When adjusting terminals that are equipped with CRT posts, the top-drilled holes in the posts need to remain at the surface of the ground.

One terminal that was used extensively on Washington's highways was the Breakaway Cable Terminal (BCT). This system used a parabolic flare similar to the Slotted Rail Terminal (SRT) and a Type 1 anchor. (Type 1 anchor posts are wood set in a steel tube or a concrete foundation.) Replace BCTs on Interstate routes. On non-Interstate routes and Interstate ramps, BCTs that have at least a 3-foot offset may remain in place unless the guardrail run or anchor is being reconstructed or reset. (Raising the rail element is not considered reconstruction or resetting.)

Existing transitions that do not have a curb but are otherwise consistent with the designs shown in the *Standard Plans* may remain in place.

### **1610.04(2) Standard Run of Barrier**

In Chapter 1100, the Design Matrices offer guidance on how to address standard barrier runs for different project types. A "Standard Run" of barrier consists of longitudinal barrier as detailed in the *Standard Plans*.

#### **1610.04(2)(a) Barrier Height Criteria**

For HMA Overlay Projects that will reduce the height of W-beam guardrail to less than 26 inches from the ground to the top of the rail element, adjust the height to a minimum of 26 inches and a maximum of 28 inches. A rail height of 28 inches is desirable to accommodate future overlays.

If Type 1 Alternate W-beam guardrail is present, raise the rail element after each overlay. If Type 1 Alternate is not present, raise the existing blockout up to 4 inches higher than the top of the existing post by boring a new hole in the post.

Overlays in front of safety shape concrete barriers can extend to the top of the lower, near-vertical face of the barrier before adjustment is necessary.

- Allow no more than 1 foot 1 inch from the pavement to the beginning of the top near-vertical face of the safety shape barriers.

- Allow no less than 2 feet 8 inches from the pavement to the top of the single-slope barrier.
- Allow no less than 35 inches to the center of the top cable for four-cable high-tension cable barriers.

**Note:** There are new high-tension cable barrier systems under development, which may change the selection and placement criteria. The Headquarters (HQ) Design Office will circulate guidance on these new developments as they are adopted as WSDOT policy.

### 1610.04(2)(b) Full Design Level (F)

When the full design level (F) is indicated the barrier is to meet the criteria in the following:

Chapter/Section	Subject
<a href="#">1600.05</a>	Medians
<a href="#">1610.05(2)</a>	Shy distance
<a href="#">1610.05(3)</a>	Barrier deflections
<a href="#">1610.05(4)</a>	Flare rate
<a href="#">1610.05(5)</a>	Length of need
<a href="#">1610.05(6)</a>	Median barrier selection and placement considerations
<a href="#">1610.06</a>	Beam guardrail
<a href="#">1610.07</a>	Cable barrier
<a href="#">1610.08</a>	Concrete barrier

Examples of barriers that are not acceptable as a “Standard Run” are:

- W-beam guardrail with 12-foot-6-inch post spacing or no blockouts, or both.
- W-beam guardrail on concrete posts.
- Cable barrier on wood or concrete posts.
- Half-moon or C-shaped rail elements.

### 1610.04(3) Bridge Rail

When the Bridge Rail column of a Design Matrix applies to the project, the bridge rails, including crossroad bridge rail, are to meet the following criteria:

- Use an approved, crash-tested concrete bridge rail on new bridges or bridges to be widened. The *Bridge Design Manual* provides examples of typical bridge rails. Consult the HQ Bridge and Structures Office regarding bridge rail selection and design and for design of the connection to an existing bridge.
- An existing bridge rail on a highway with a posted speed of 30 mph or below may remain in place if it is not located on a bridge over a National Highway System (NHS) highway. When Type 7 bridge rail is present on a bridge over an NHS highway with a posted speed of 30 mph or below, it may remain in place regardless of the type of metal rail installed. Other bridge rails are to be evaluated for strength and geometrics. (See [1610.10](#) for guidance on retrofit techniques.)
- The Type 7 bridge rail is common. Type 7 bridge rails have a curb, a vertical-face parapet, and an aluminum top rail. The curb width and the type of aluminum top rail are factors in determining the adequacy of the Type 7 bridge rail, as shown in [Exhibit 1610-1](#). Consult the HQ Bridge and Structures Office for assistance in evaluating other bridge rails.



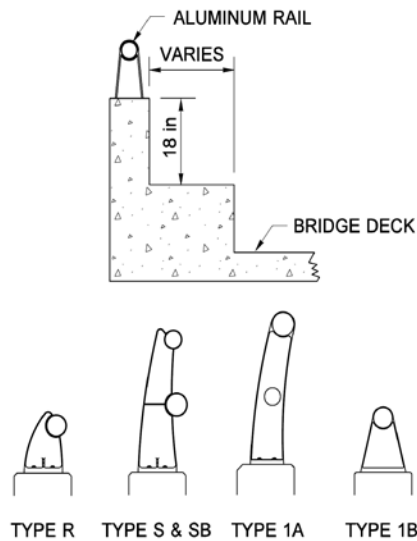

Aluminum Rail Type	Curb Width	
	9 Inches or Less	Greater Than 9 Inches*
Type R, S, or SB	Bridge rail adequate	Bridge rail adequate
Type 1B or 1A	Bridge rail adequate	Upgrade bridge rail
Other	Consult the HQ Bridge and Structures Office	

\*When the curb width is greater than 9 inches, the aluminum rail must be able to withstand a 5 kip load.

**Type 7 Bridge Rail Upgrade Criteria**  
*Exhibit 1610-1*

## 1610.05 Barrier Design

When selecting a barrier, consider the flexibility, cost, and maintainability of the system. It is generally desirable to use the most flexible system possible to minimize damage to the impacting vehicle and injury to the vehicle's occupant(s). However, since nonrigid systems sustain more damage during an impact, the exposure of maintenance crews to traffic might be increased with the more frequent need for repairs.

Maintenance costs for concrete barrier are lower than for other barrier types. In addition, deterioration due to weather and vehicle impacts is less than most other barrier systems. Unanchored precast concrete barrier can usually be realigned or repaired when moved from its alignment. However, heavy equipment may be necessary to reposition or replace barrier segments. Therefore, in medians, consider the shoulder width and the traffic volume when determining the acceptability of unanchored precast concrete barrier versus rigid concrete barrier.

Drainage, alignment, and drifting snow or sand are considerations that can influence the selection of barrier type. Beam guardrail and concrete barrier can contribute to snow drifts. Consider long-term maintenance costs associated with snow removal at locations prone to snow drifting. Slope flattening is recommended when the safety benefit justifies the additional cost to eliminate the need for the barrier. Cable barrier is not an obstruction to drifting snow and can be used if slope flattening is not feasible.

With some systems, such as concrete and beam guardrail, additional shoulder widening or slope flattening is common. However, selection of these types of barriers is sometimes limited due to the substantial environmental permitting and highway reconstruction needs. Permits issued under the SEPA and NEPA processes may lead to the use of a barrier design such as cable barrier, which has fewer potential environmental impacts and costs.

**1610.05(1) Sight Distance**

When selecting and placing a barrier system, consider the possible impact the barrier type and height may have on sight distance. In some cases, barriers may restrict the sight distances of road users entering the roadway, such as from road approaches, intersections, and other locations. In these cases, the barrier may need to be adjusted to meet the required sight distance requirements at these locations.

**1610.05(2) Shy Distance**

Provide 2 feet of additional widening for shy distance when a barrier is to be installed in areas where the roadway is to be widened and the shoulder width will be less than 8 feet. This shy distance is not needed when the section of roadway is not being widened or the shoulders are at least 8 feet wide. (See criteria in [Chapter 1140](#) for exceptions.)

**1610.05(3) Barrier Deflections**

Expect all barriers except rigid barriers (such as concrete bridge rails) to deflect when hit by an errant vehicle. The amount of deflection is primarily dependent on the stiffness of the system. However, vehicle speed, angle of impact, and weight also affect the amount of barrier deflection. For flexible and semirigid roadside barriers, the deflection distance is designed to help prevent the impacting vehicle from striking the object being shielded. For unrestrained rigid systems (unanchored precast concrete barrier), the deflection distance is designed to help prevent the barrier from being knocked over the side of a drop-off or steep fill slope (2H:1V or steeper).

In median installations, design systems such that the anticipated deflection will not enter the lane of opposing traffic using deflection values that were determined from crash tests. When evaluating new barrier installations, consider the impacts where significant traffic closures are necessary to accomplish maintenance. Use a rigid system where deflection cannot be tolerated, such as in narrow medians or at the edge of bridge decks or other vertical drop-off areas. Runs of rigid concrete barrier can be cast in place or extruded with appropriate footings.

In some locations where deflection distance is limited, anchor precast concrete barrier. Unless the anchoring system has been designed to function as a rigid barrier, some movement can be expected and repairs may be more expensive. Use of an anchored or other deflecting barrier on top of a retaining wall without deflection distance provided requires approval from the HQ Design Office.

Refer to [Exhibit 1610-2](#) for barrier deflection design values when selecting a longitudinal barrier. The deflection distances for cable and beam guardrail are the minimum measurements from the face of the barrier to the fixed feature. The deflection distance for unanchored concrete barrier is the minimum measurement from the back edge of the barrier to the drop-off or slope break.

Barrier Type	System Type	Deflection
Cable barrier or beam guardrail, Types 20 and 21, on G-2 posts	Flexible	Up to 12 ft (face of barrier to object)
Beam guardrail, Types 1, 1a, 2, 10, and 31	Semirigid	3 ft (face of barrier to object)
Two-sided W-beam guardrail, Types 3 and 4	Semirigid	2 ft (face of barrier to object)
Permanent concrete barrier, unanchored	Rigid Unrestrained	3 ft <sup>[1]</sup> (back of barrier to object)
Temporary concrete barrier, unanchored	Rigid Unrestrained	2 ft <sup>[2]</sup> (back of barrier to object)
Precast concrete barrier, anchored	Rigid Anchored	6 inches (back of barrier to object)
Rigid concrete barrier	Rigid	No deflection

**Notes:**

[1] When placed in front of a 2H:1V or flatter fill slope, the deflection distance can be reduced to 2 feet.

[2] When used as temporary bridge rail, anchor all barrier within 3 feet of a drop-off.

### Longitudinal Barrier Deflection *Exhibit 1610-2*

#### 1610.05(4) Flare Rate

Flare the ends of longitudinal barriers where practicable. The four functions of a flare are to:

- Locate the barrier and its terminal as far from the traveled way as feasible.
- Reduce the length of need.
- Redirect an errant vehicle.
- Minimize a driver's reaction to the introduction of an object near the traveled way.

Keeping flare rates as flat as practicable preserves the barrier's redirection performance and minimizes the angle of impact. However, it has been shown that an object (or barrier) close to the traveled way might cause a driver to shift laterally, slow down, or both. The flare reduces this reaction by gradually introducing the barrier so the driver does not perceive the barrier as an object to be avoided. The flare rates in [Exhibit 1610-3](#) are intended to satisfy the four functions listed above. More gradual flares may be used. Flare rates are offset parallel to the edge of the traveled way. Transition sections are not normally flared.

Posted Speed (mph)	Rigid & Rigid Anchored System	Unrestrained Rigid System	Semirigid System
65–70	20:1	18:1	15:1
60	18:1	16:1	14:1
55	16:1	14:1	12:1
50	14:1	12:1	11:1
45	12:1	11:1	10:1
40 or below	11:1	10:1	9:1

### Longitudinal Barrier Flare Rates

*Exhibit 1610-3*

#### 1610.05(5) Length of Need

The length of traffic barrier needed to shield a fixed feature (length of need) is dependent on the location and geometrics of the object, direction(s) of traffic, posted speed, traffic volume, and type and location of traffic barrier. When designing a barrier for a fill slope (see [Chapter 1600](#)), the length of need begins at the point where the need for barrier is recommended. For fixed objects and water, Exhibits [1610-10a](#) and [10b](#) show design parameters for determining the needed length of a barrier for both adjacent and opposing traffic on relatively straight sections of highway.

When barrier is to be installed on the outside of a horizontal curve, the length of need can be determined graphically, as shown in [Exhibit 1610-10c](#). For installations on the inside of a curve, determine the length of need as though it were straight. Also, consider the flare rate, barrier deflection, and barrier end treatment to be used.

When beam guardrail is placed in a median, consider the potential for impact from opposing traffic when conducting a length of need analysis. When guardrail is placed on either side of objects in the median, consider whether the trailing end of each run of guardrail will shield the leading end of the opposing guardrail. Shield the leading end when it is within the Design Clear Zone of opposing traffic (see [Exhibit 1610-10d](#)). This is also a consideration when objects are placed in the outer separations between the main line and collector-distributors.

Before the actual length of need is determined, establish the lateral distance between the proposed barrier installation and the object shielded. Provide a distance that is greater than or equal to the anticipated deflection of the longitudinal barrier. (See [Exhibit 1610-2](#) for barrier deflections.) Place the barrier as far from the edge of the traveled way as possible while maintaining the deflection distance.

If the end of the length of need is near an adequate cut slope, extend the barrier and embed it in the slope (see [1610.06\(5\)](#)). Avoid gaps of 300 feet or less. Short gaps are acceptable when the barrier is terminated in a cut slope. If the end of the length of need is near the end of an existing barrier, it is recommended that the barriers be connected to form a continuous barrier. Consider maintenance access issues when determining whether or not to connect barriers.

### 1610.05(6) Median Barrier Selection and Placement Considerations

The most desirable barrier installation uses the most flexible system appropriate for the location and one that is placed as far from the traveled way as practicable. Engineers are faced with the fact that barrier systems and vehicle fleets continue to evolve. What may be an optimal choice of barrier based on the majority of vehicles on the road today may not be the best selection for vehicles on the road in the foreseeable future. This continuum of change does not allow engineers to predict the future with any degree of certainty. Consequently, engineering decisions need to be made based on the most reliable and current information.

Engineers are constantly striving to develop more effective design features to improve highway safety. However, economics and feasibility do not permit new designs to be employed as soon as they are invented. The fact that a new design has been developed does not mean that the old design is unsafe. Although new designs may have been tested under controlled conditions, their performance under relevant applications may demonstrate unexpected performance aspects. Therefore there may be a need to modify application methods based on that practical experience.

Good engineering judgment is called for in determining the appropriate placement of barrier systems. Solutions may need to be arrived at while considering competing factors such as collision frequency and severity. As discussed previously, performance of the system relies on the interaction of the vehicle, driver, and system design at any given location. Additionally, the ability to access the system for maintenance and availability of parts plays into the final decision.

With median barriers, the deflection characteristics and placement of the barrier for a traveled way in one direction can have an impact on the traveled way in the opposing direction. In addition, the median slopes and environmental issues often influence the type of barrier that is appropriate.

In narrow medians, avoid placement of barrier where the design deflection extends into oncoming traffic. Narrow medians provide little space for maintenance crews to repair or reposition the barrier. Therefore, avoid installing deflecting barriers in medians that provide less than 8 feet from the edge of the traveled way to the face of the barrier.

In wider medians, the selection of barrier might depend on the slopes in the median. At locations where the median slopes are relatively flat (10H:1V or flatter), unrestrained precast concrete barrier, beam guardrail, and cable barrier can be used depending on the available deflection distance. At these locations, position the barrier as close to the center as possible so that the recovery distance can be maximized for both directions. There may be a need to offset the barrier from the flow line to avoid impacts to the drainage flow.

In general, cable barrier is recommended with medians that are 30 feet or wider. However, cable barrier may be appropriate for narrower medians if adequate deflection distance exists. In wide medians where the slopes are steeper than 10H:1V but not steeper than 6H:1V, cable barrier placed near the center of the median is preferable. For additional cable barrier placement guidance, see Exhibits 1610-13a through 13c. Place beam guardrail at least 12 feet from the slope breakpoint, as shown in Exhibit 1610-4. Do not use concrete barrier at locations where the foreslope into the face of the barrier is steeper than 10H:1V.

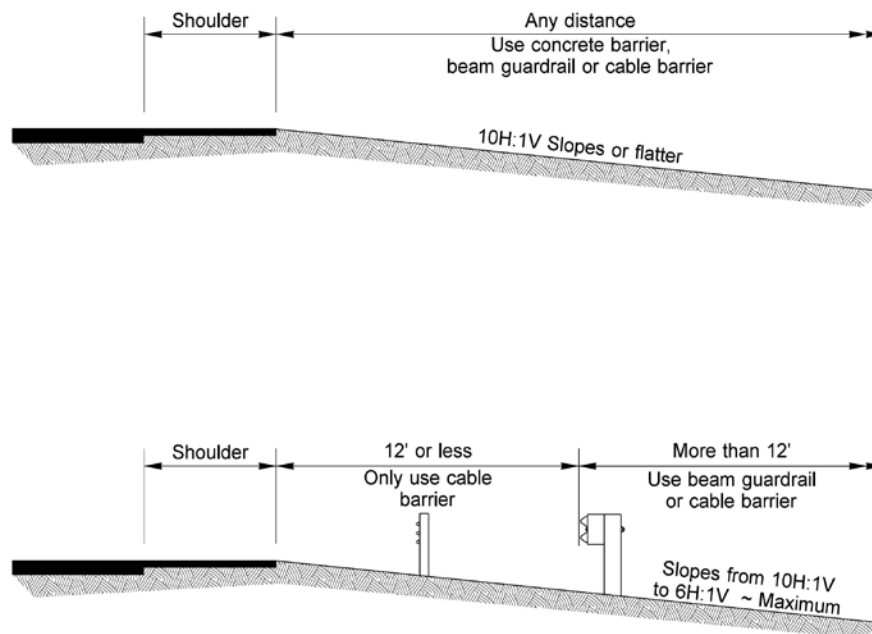

### Traffic Barrier Locations on Slopes

#### Exhibit 1610-4

At locations where the roadways are on independent alignments and there is a difference in elevation between the roadways, the slope from the upper roadway might be steeper than 6H:1V. In these locations, position the median barrier along the upper roadway and provide deflection and offset distance as discussed previously. Barrier is generally not needed along the lower roadway except where there are fixed features in the median.

When W-beam barrier is placed in a median as a countermeasure for cross-median collisions, design the barrier to be struck from either direction of travel. For example, the installation of beam guardrail might be double-sided (Type 31-DS).

#### **1610.05(7) Aesthetic Barrier Treatment**

When designing a barrier for use on a Scenic Byway, consider barriers that are consistent with the recommendations in the associated corridor management plan (if one is available). Contact the region Landscape Architect or the Scenic Byways Coordinator in the HQ Highways and Local Programs Office to determine whether the project is on such a designated route. Low-cost options, such as using weathering steel beam guardrail (see [1610.06](#)) or cable barrier (see [1610.07](#)), might be feasible on many projects. Higher-cost options, such as steel-backed timber rail and stone guardwalls (see [1610.09](#)), might necessitate a partnering effort to fund the additional costs. Grants might be available for this purpose if the need is identified early in the project definition phase (see [Chapter 120](#)).

#### **1610.05(8) Barrier Delineation**

Refer to [1030.06](#) for delineation requirements.

## 1610.06 Beam Guardrail

### 1610.06(1) Beam Guardrail Systems

Beam guardrail systems are shown in the *Standard Plans*.

Strong post W-beam guardrail (Types 1 through 4, and 31) and three beam guardrail (Types 10 and 11) are semirigid barriers used predominantly on roadsides. They have limited application as median barrier. Installed incorrectly, strong post W-beam guardrail can cause vehicle snagging or spearing. This can be avoided by lapping the rail splices in the direction of traffic (as shown in the *Standard Plans*), by using crash-tested end treatments, and by blocking the rail away from the strong posts. However, avoid the use of blockouts that extend from the post to the rail element for a distance exceeding 16 inches. Placement of curb at guardrail installations also requires careful consideration.

Previously, WSDOT standard practice was to install W-beam guardrail at a rail height of 27 inches. However, there are newer designs that use a 31-inch rail height. One is the 31-inch-high WSDOT Type 31. The Type 31 system uses many of the same components as the WSDOT Type 1 system. However, the main differences are that the blockouts extend 12 inches from the posts, the rail height is 31 inches from the ground to the top of the rail, and the rail elements are spliced between posts.

The 31-inch-high system offers tolerance for future HMA overlays. The Type 31 system allows a 3-inch tolerance from 31 inches to 28 inches without adjustment of the rail element.

### 1610.06(2) W-Beam Barrier Selection and Placement

During the project development processes, consult with maintenance staff to help identify guardrail runs that may need to be upgraded.

- Use the 31-inch-high guardrail design for new runs. When guardrail is installed along existing shoulders with a width greater than 4 feet, the shoulder width may be reduced by 4 inches to accommodate the 12-inch blockout without processing a deviation.
- Existing runs with rail height at 27 inches are acceptable to leave in place and can be extended if the design height of 27 inches is maintained in the extended section. Where future overlays are anticipated, extend with Type 1 alternate or the 31-inch design.
- For existing runs below 26 inches, adjust or replace the rail to a height of 26 inches minimum to 28 inches maximum, or replace the run with the 31-inch-high guardrail design.
- Some 31-inch-high proprietary guardrail designs that do not incorporate the use of blockouts have been successfully crash-tested. The use of this type of system may be appropriate for some applications. Contact the HQ Design Office for further details.

Some designs for Type 31 applications are under development and will be added to the HQ Design Standards (Plan Sheet Library: [www.wsdot.wa.gov/design/standards/plansheet](http://www.wsdot.wa.gov/design/standards/plansheet)) as soon as they are completed. Plans will be housed at this location until they are transitioned into the *Standard Plans*. **Note:** If a design is not available for the Type 31 guardrail system, a Type 1 guardrail design may be used.

**1610.06(3) Beam Guardrail Post Selection Criteria**

- WSDOT has experienced inconsistencies in the service life of wood guardrail posts. As a result, WSDOT conducted a life cycle analysis and has elected to discontinue the use of wood guardrail posts for new guardrail runs. Use steel posts for new beam guardrail runs.
- Existing runs of guardrail with wooden posts are acceptable to leave in place if in good condition and minimum height criteria can be maintained. (See [1610.06\(2\)](#) for additional guidance.)
- Posts in an existing wooden guardrail run may be replaced in kind.
- It is acceptable to extend existing wood post guardrail runs with either steel or wood posts and also with the associated approved wood or steel post terminals and anchors.
- When removing and resetting guardrail runs, consider using steel posts and reusing or replacing other components and hardware depending on condition.

**1610.06(4) Additional Guidance**

- Weak post W-beam guardrail (Type 20) and thrie beam guardrail (Type 21) are flexible barrier systems that can be used where there is adequate deflection distance (see the [Standard Plans](#)). These systems use weak steel posts. The primary purpose of these posts is to position the guardrail vertically, and they are designed to bend over when struck. These more flexible systems will likely result in less damage to the impacting vehicle. Since the weak posts will not result in snagging, blockouts are not necessary.
- Keep the slope of the area between the edge of the shoulder and the face of the guardrail 10H:1V or flatter. On fill slopes between 6H:1V and 10H:1V, avoid placing within 12 feet of the break point. Do not place beam guardrail on a fill slope steeper than 6H:1V. (See [Exhibit 1610-4](#) for additional guidance on beam guardrail slope placement.)
- On the high side of superelevated sections, place beam guardrail at the edge of shoulder prior to the slope break.
- For W-beam guardrail installed at or near the shoulder, 2 feet of shoulder widening behind the barrier is generally provided from the back of the post to the beginning of a fill slope (see [Exhibit 1610-11](#), Case 2). If the slope is 2H:1V or flatter, this distance can be measured from the face of the guardrail rather than the back of the post (see [Exhibit 1610-11](#), Case 1).
- On projects where no roadway widening is proposed and the minimum 2-foot shoulder widening behind the barrier is not practicable, long post installations are available as shown in [Exhibit 1610-11](#), Cases 3, 4, 5, and 6. When guardrail is to be installed in areas where the roadway is to be widened or along new alignments, the use of Cases 5 and 6 requires a design deviation.
- Rail washers on beam guardrail are not normally used. If rail washers are present, removal is not necessary except for posts 2 through 8 of an existing BCT installation. However, if the rail element is removed for any reason, do not reinstall rail washers. In areas where heavy snow accumulations are expected to cause the bolts to pull out, specify snowload post washers and rail washers in the contract documents. (Snowload post washers are used to help prevent the bolts from pulling through the posts, and snowload rail washers are used to help prevent the bolt head from pulling through the rail.) In other installations, it is normal to have the rail pull loose from the bolt head when impacted. Do not use rail washers within the limits of a guardrail terminal except at the end post where they are needed for anchorage of the rail.



- The use of curb in conjunction with beam guardrail is discouraged. If a curb is needed, the 3-inch-high curb is preferred. If necessary, the 4-inch-high extruded curb can be used behind the face of rail at any posted speed. The 6-inch-high extruded curb can be used at locations where the posted speed is 50 mph or below. When replacing extruded curb at locations where the posted speed is above 50 mph, use 3-inch-high or 4-inch-high curb. (See the [Standard Plans](#) for extruded curb designs.)
- **Note:** When used in conjunction with the 31-inch-high Type 31 W-beam guardrail, an acceptable option is to place up to a 6-inch-high extruded curb at a maximum 6-inch offset outside the face of the rail at any posted speed. Contact the WSDOT Design Office for more information.
- Beam guardrail is usually galvanized and has a silver color. It can also be provided in weathering steel that has a brown or rust color. Along Scenic Byways, Heritage Tour Routes, state highways through national forests, or other designated areas where aesthetic barrier is needed, consider using weathering steel guardrail, colored terminals (powder-coated galvanized steel), and colored steel posts (galvanized weathering steel or powder-coated galvanized steel) to minimize the barrier's visual impact (see [1610.05\(7\)](#)).
- In areas where weathering steel will be used and the steel post options cannot be used because of stakeholder constraints (for example, those listed in a "Corridor Management Plan"), the wood post option may be used with justification (Design Decision Memo).
- There are new methods under development that may change the options for providing colored guardrail to meet the aesthetic barrier. The HQ Design Office will circulate guidance on these new developments as they are adopted as WSDOT policy.

### 1610.06(5) Terminals and Anchors

A guardrail anchor is needed at the end of a run of guardrail to develop tensile strength throughout its length. In addition, when the end of the guardrail is subject to head-on impacts, a crash-tested guardrail terminal is needed (see the [Standard Plans](#)).

#### 1610.06(5)(a) Buried Terminal (BT)

A buried terminal is designed to terminate the guardrail by burying the end in a backslope. The BT is the preferred terminal because it eliminates the exposed end of the guardrail.

The BT uses a Type 2 anchor to develop the tensile strength in the guardrail. The backslope needed to install a BT is to be 3H:1V or steeper and at least 4 feet in height above the roadway. The entire BT can be used within the length of need for backslopes of 1H:1V or steeper if the barrier remains at full height in relation to the roadway shoulder to the point where the barrier enters the backslope. For backslopes between 1H:1V and 3H:1V, design the length of need beginning at the point where the W-beam remains at full height in relation to the roadway shoulder—usually beginning at the point where the barrier crosses the ditch line. If the backslope is flatter than 1H:1V, provide a minimum 20-foot-wide by 75 foot-long distance behind the barrier and between the beginning length of need point at the terminal end to the mitigated object to be protected.

For new BT installations, use the Buried Terminal Type 2. **Note:** Previously, another BT option (the Buried Terminal Type 1) was an available choice. For existing situations, it is acceptable to leave this option in service as long as height requirements and other previous design criteria can still be met.

## 1. Buried Terminal Type 2

Flare the guardrail to the foreslope/backslope intersection using a flare rate that meets the criteria in [1610.05\(4\)](#). Provide a 4H:1V or flatter foreslope into the face of the guardrail and maintain the full guardrail height to the foreslope/backslope intersection in relation to a 10H:1V line extending from edge of shoulder breakpoint. (See the *Standard Plans* for details.)

### 1610.06(5)(b) Nonflared Terminal

If a BT terminal cannot be installed as described in [1610.06\(5\)\(a\)](#), consider a nonflared terminal (see [Exhibit 1610-12a](#)). For Type 31 guardrail systems, there are currently two acceptable sole source proprietary designs: the ET-31 and the SKT-SP-MGS. These systems use W-beam guardrail with a special end piece that fits over the end of the guardrail. Steel posts are used throughout the length of the terminal. When hit head on, the end piece is forced over the rail and either flattens or bends the rail and then forces it away from the impacting vehicle.

Both the SKT-SP-MGS and the ET-31 terminals include an anchor for developing the tensile strength of the guardrail. The length of need begins at the third post for both terminals. Both of these terminals are available in two designs, which are based on the posted speed of the highway. For highways with a posted speed of 45 mph or above, use the ET-31 (TL3) or the SKT-SP-MGS (TL3) terminal. For lower-speed highways (a posted speed of 40 mph or below), use the ET-31 (TL2) or SKT-SP-MGS (TL2).

While these terminals do not need to have an offset at the end, a flare is recommended so that the end piece does not protrude into the shoulder. These terminals may have a 2-foot offset to the first post. Four feet of widening is needed at the end posts to properly anchor the system. When widening includes an embankment, fill material will be necessary for optimum terminal performance. (See the *Standard Plans* for widening details.)

When the entire barrier run is located farther than 12 feet beyond the shoulder break point and the slopes are greater than 10H:1V and 6H:1V or flatter, additional embankment at the terminal is not needed.

No snowload rail washers are allowed within the limits of these terminals.

When a Beam Guardrail Type 1 nonflared terminal is needed, two sole source proprietary terminals, the ET-PLUS or the Sequential Kinking Terminal (SKT), may be used (see [Exhibit 1610-12b](#)). Both of these Type 1 barrier terminals are available in two designs based on the posted speed of the highway. The primary difference in these designs is the length of the terminal. For highways with a posted speed of 45 mph or above, use the 50-foot-long ET PLUS TL3 or the SKT 350 terminal. For lower-speed highways (a posted speed of 40 mph or below), use the 25 foot-long ET PLUS TL2 or SKT-TL2.

The FHWA has granted approval to use the above sole source nonflared proprietary terminals without justification.

**Note:** Approved shop drawings for terminals can be found by accessing the following website:  
[www.wsdot.wa.gov/design/policy/trafficbarriers.htm](http://www.wsdot.wa.gov/design/policy/trafficbarriers.htm)

### 1610.06(5)(c) Flared Terminal

WSDOT does not use a flared terminal system for the Type 31 system. However, if a flared terminal is needed for other applications, there are currently two acceptable sole source proprietary designs: the Slotted Rail Terminal (SRT) and the Flared Energy Absorbing Terminal (FLEAT). Both of these designs include an anchor for developing the tensile strength of the guardrail. The length of need begins at the third post for both flared terminals.

1. The SRT uses W-beam guardrail with slots cut into the corrugations and posts throughout the length of the terminal. The end of the SRT is offset from the tangent guardrail run by the use of a parabolic flare. When struck head on, the first two posts are designed to break away, and the parabolic flare gives the rail a natural tendency to buckle, minimizing the possibility of the guardrail end entering the vehicle. The buckling is facilitated by the slots in the rail. The remaining posts provide strength to the system for redirection and deceleration without snagging the vehicle. The SRT has a 4 foot offset of the first post.

The SRT terminal can be supplied with wood or steel posts. Match the type of SRT posts with those of the longitudinal barrier run to which the terminal will be connected.

2. The FLEAT uses W-beam guardrail with a special end piece that fits over the end of the guardrail and posts. The end of the FLEAT is offset from the tangent guardrail run by the use of a straight flare. When struck head on, the end piece is forced over the rail, bending the rail and forcing it away from the impacting vehicle.

**Note:** Approved shop drawings for terminals can be found by accessing the following website:  
[www.wsdot.wa.gov/design/policy/trafficbarriers.htm](http://www.wsdot.wa.gov/design/policy/trafficbarriers.htm)

The FLEAT is available in two designs based on the posted speed of the highway. For highways with a posted speed of 45 mph or above, use a FLEAT 350, which has a 4-foot offset at the first post. For lower-speed highways (a posted speed of 40 mph or below), use a FLEAT TL-2, which has a 1 foot-8-inch offset at the first post.

The FLEAT terminal can be supplied with wood or steel posts. Match the type of FLEAT posts with those of the longitudinal barrier run to which the terminal will be connected.

When a flared terminal is specified, it is critical that the embankment quantity also be specified so that the area around the terminal can be constructed as shown in the [Standard Plans](#).

When the entire barrier run is located greater than 12 feet beyond the shoulder break point and the slopes are greater than 10H:1V and 6H:1V or flatter, additional embankment at the terminal is not needed.

Snowload rail washers are not allowed within the limits of these terminals.

The FHWA has granted approval to use the SRT and the FLEAT sole source proprietary flared terminals without justification.

### 1610.06(5)(d) Terminal Evolution Considerations

Some currently approved terminals have been in service for a number of years. During this time, there have been minor design changes. However, these minor changes have not changed the devices' approval status. Previous designs for these terminals may remain in place. (For guidance on BCT terminals, see [1610.04\(1\)](#).)

**Note:** If questions arise concerning the current approval status of a device, contact the HQ Design Office for clarification when replacement is being considered.

**1610.06(5)(e) Other Anchor Applications**

Use the Type 10 anchor to develop the tensile strength of the guardrail on the end of Type 31 guardrail runs where a crash-tested terminal is not needed. The Type 1 or Type 4 anchor is used for older Beam Guardrail Type 1 where a crash-tested terminal is not needed. Use the Type 5 anchor with the Weak Post Intersection Design (see 1610.06(7)(b), Cases 12 and 13). Use the Type 7 anchor to develop tensile strength in the middle of a guardrail run when the guardrail curves and weak posts are used (see 1610.06(7)(b), Cases 9, 12, and 13).

The old Type 3 anchor was primarily used at bridge ends (see Exhibit 1610-5). This anchor consisted of a steel pipe mounted vertically in a concrete foundation. Bridge approach guardrail was then mounted on the steel pipe.

- On one-way highways, these anchors were usually positioned so that neither the anchor nor the bridge rail posed a snagging potential. When these cases are encountered, the anchor may remain in place if a stiffened transition section is provided at the connection to the post.
- On two-way highways, the anchor may present a snagging potential. In these cases, install a connection from the anchor to the bridge rail if the offset from the bridge rail to the face of the guardrail is 1 foot 6 inches or less. If the offset is greater than 1 foot 6 inches, remove the anchor and install a new transition and connection.

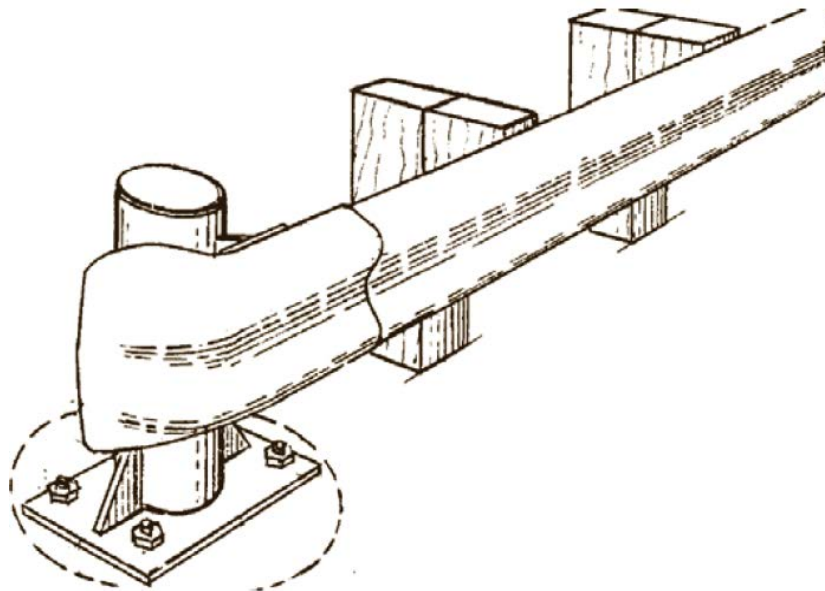

**Old Type 3 Anchor**  
*Exhibit 1610-5*

Locations where crossroads and driveways cause gaps in the guardrail create situations for special consideration. Elimination of the need for the barrier is the preferred solution. Otherwise, a barrier flare might be needed to provide sight distance. If the slope is 2H:1V or flatter and there are no fixed features on or at the bottom of the slope, a terminal can be used to end the rail (see Chapters 1310 and 1340 for additional sight distance guidance). Place the anchor of this installation as close as possible to the road approach radius PC.

### 1610.06(6) Transitions and Connections

When there is an abrupt change from one barrier type to a more rigid barrier type, a vehicle hitting the more flexible barrier is likely to be caught in the deflected barrier pocket and directed into the more rigid barrier. This is commonly referred to as “pocketing.” A transition stiffens the more flexible barrier by decreasing the post spacing, increasing the post size, and using stiffer beam elements to eliminate the possibility of pocketing.

When connecting beam guardrail to a more rigid barrier or a structure, or when a rigid object is within the deflection distance of the barrier, use the transitions and connections that are shown in Exhibits 1610-6 and 1610-9 and detailed in the *Standard Plans*. The transition pay item includes the connection.

Condition	Connection
Unrestrained concrete barrier	A
Rigid, rigid anchored, untapered safety shape bridge rails or barriers <sup>[1]</sup>	B
Bridge rails with curbs 9 inches or less in width	B
Bridge rails with curbs between 9 and 18 inches wide	C
Vertical walls, <u>single slope</u> , or tapered safety shape barrier <sup>[1]</sup>	D
<b>Note:</b>	
[1] New <u>single slope and</u> safety shape bridge rails are designed with the toe of the barrier tapered so that it does not project past the face of the approach guardrail.	

#### Guardrail Connections

Exhibit 1610-6

### 1610.06(7) Guardrail Placement Cases

The *Standard Plans* contains placement cases that show beam guardrail elements needed for typical situations. For some applications, the *Standard Plans* provides options for both Type 1 and Type 31 guardrail for similar installations. For new installations, use the appropriate Type 31 placement option. Additional placement cases incorporate other combinations of barrier types.

#### 1610.06(7)(a) Beam Guardrail Type 31 Placements (for new installations)

- **Case 1-31** is used where there is one-way traffic. It uses a crash-tested terminal on the approach end and a Type 10 anchor on the trailing end.
- **Case 2-31** is used where there is two-way traffic. A crash-tested terminal is used on both ends.
- **Case 3-31** is used at railroad signal supports on one-way or two-way roadways. A terminal is used on the approach end, but usually cannot be used on the trailing end because of its proximity to the railroad tracks. If there is a history of crossover accidents, consider additional protection such as an impact attenuator.
- **Case 4-31** is used where guardrail on the approach to a bridge is to be shifted laterally to connect with the bridge rail. A terminal is used on the approach end and a transition is needed at the bridge end. A curve in the guardrail is shown to shift it to the bridge rail. However, the length of the curve is not critical. The criterion is to provide a smooth curve that is not more abrupt than the allowable flare rate (see [Exhibit 1610-3](#)).

- **Case 5-31** is a typical bridge approach where a terminal and a transition are needed.
- **Case 6** is used on bridge approaches where opposing traffic is separated by a median that is 36 feet or wider. This case is designed so that the end of the guardrail will be outside the Design Clear Zone for the opposing traffic.
- **Case 10 (A-31, B-31, and C-31)** is used at roadside fixed features (such as bridge piers) when 3 or more feet are available from the face of the guardrail to the feature. The approach end is the same for one-way or two-way traffic. Case 10A-31 is used with two-way traffic; therefore, a terminal is needed on the trailing end. Case 10B-31 is used for one-way traffic when there is no need to extend guardrail past the bridge pier and a Type 10 anchor is used to end the guardrail. Case 10C-31 is used for one-way traffic when the guardrail will extend for a distance past the bridge pier.
- **Case 11 (A-31, B-31, and C-31)** is used at roadside fixed features (such as bridge piers) when the guardrail is to be placed within 3 feet of the feature. Since there is no room for deflection, the rail in front of the feature is to be considered a rigid system and a transition is needed. The trailing end cases are the same as described for Case 10.
- **Beam Guardrail Type 31 (12'6", 18'9", or 25' Span)** is used when it is necessary to omit one, two, or three posts. This application is typically used when guardrail is installed over drainage structures but may have other applications if adequate deflection distance is present. Three CRT posts are provided on each end of the omitted post(s).
- **Guardrail Placement Strong Post – Type 31** is the “Strong Post Intersection Design for Type 31 barrier” that provides a stiff barrier. This design is used at crossroads or road approaches where a barrier is needed and where the length of need cannot be achieved using standard components such as standard longitudinal barrier runs, transitions, and terminals.

*Note:* Some placement cases for use with Beam Guardrail Type 31 are currently under development. As plans become available, they will be housed in the HQ Design Standards (Plan Sheet Library) until they become Standard Plans ([www.wsdot.wa.gov/design/standards/plansheet](http://www.wsdot.wa.gov/design/standards/plansheet)).

#### **1610.06(7)(b) Additional Placement Cases (typically, for existing installations)**

- **Case 1** is used where there is one-way traffic. It uses a crash-tested terminal on the approach end and a Type 4 anchor on the trailing end.
- **Case 2** is used where there is two-way traffic. A crash-tested terminal is used on both ends. When flared terminals are used on both ends, use a minimum of 25 feet of guardrail between the terminal limits when feasible.
- **Case 3** is used at railroad signal supports on one-way or two-way roadways. A terminal is used on the approach end, but usually cannot be used on the trailing end because of its proximity to the railroad tracks. If there is a history of crossover accidents, consider additional protection such as an impact attenuator.
- **Case 4** is used where guardrail on the approach to a bridge is to be shifted laterally to connect with the bridge rail. A terminal is used on the approach end and a transition is needed at the bridge end. A curve in the guardrail is shown to shift it to the bridge rail. However, the length of the curve is not critical. The criterion is to provide a smooth curve that is not more abrupt than the allowable flare rate (see [Exhibit 1610-3](#)).
- **Case 5** is a typical bridge approach where a terminal and a transition are needed.
- **Case 6** is used on bridge approaches where opposing traffic is separated by a that is 36 feet or wider. This case is designed so that the end of the guardrail will be outside the Design Clear Zone for the opposing traffic.

- **Cases 7 and 8** are used with beam guardrail median barrier when median fixed features such as bridge piers are encountered. A transition is needed on the approach end for each direction, and the flare rate is not to be more abrupt than the allowable flare rate (see [Exhibit 1610-3](#)).
- **Case 9 (A, B, and C)** is used on bridge approaches where opposing traffic is separated by a median less than 36 feet wide. This design, called a “Bull Nose Terminal,” treats both bridge ends and the opening between the bridges. The “nose” is designed to collapse when struck head on, and the ribbon strength of the rail brings the vehicle to a controlled stop. Type 7 anchors are installed on each side of the nose to develop the ribbon strength. Since an impacting vehicle might penetrate into the system, it is critical that no fixed feature be located within the first 65 feet of the system.
- **Case 10 (A, B, and C)** is used at roadside fixed features (such as bridge piers) when 3 or more feet are available from the face of the guardrail to the object. The approach end is the same for one-way or two-way traffic. Case 10A is used with two-way traffic; therefore, a terminal is needed on the trailing end. Case 10B is used for one-way traffic when there is no need to extend guardrail past the bridge pier and a Type 4 anchor is used to end the guardrail. Case 10C is used for one-way traffic when the guardrail will extend for a distance past the bridge pier.
- **Case 11 (A, B, and C)** is used at roadside fixed features (such as bridge piers) when the guardrail is to be placed within 3 feet of the object. Since there is no room for deflection, the rail in front of the feature is to be considered a rigid system and a transition is needed. The trailing end cases are the same as described for Case 10.
- **Cases 12 and 13** are called “Weak Post Intersection Designs.” They are used where an intersection design needs a gap in the guardrail or there is not adequate space for a bridge approach installation that includes a transition, a terminal, or both. These placements are designed to collapse when hit at the nose, and the ribbon strength of the rail brings the vehicle to a stop. A Type 7 anchor is used to develop the ribbon strength. These designs include a Type 5 transition for connection with bridge rail and a Type 5 anchor at the other end of the rail. The Type 5 anchor is not a breakaway anchor and therefore can typically be used only in situations where a crash-tested terminal is not needed; for example, where slow-moving vehicles are anticipated, such as some side roads and driveways.

Since an impacting vehicle might penetrate into the system, it is critical that no fixed feature be located within the clear area shown in the [Standard Plans](#). The 25 feet of barrier length beyond the PC along the side road are critical for the operation of this system.

These designs were developed for intersections that are approximately perpendicular. Evaluate installation on skewed intersections on a case-by-case basis. Use the Case 22 placement if it is not feasible to install this design according to the [Standard Plans](#).

- **Case 14** shows the approach rail layout for a Service Level 1 bridge rail system. Type 20 guardrail is used on the approach and no transition is needed between the Type 20 guardrail and the Service Level 1 bridge rail since they are both weak post systems. A Type 6 transition is used when connecting the Type 20 to a strong post guardrail or a terminal.
- **Case 15** is used to carry guardrail across a box culvert where there is insufficient depth to install standard posts for more than 17 feet 8 inches. This design uses steel posts anchored to the box culvert to support the rail. Newer designs—Cases 19, 20, and 21—have replaced this design for shorter spans.
- **Cases 16 and 17** are similar to Cases 1 and 2, except that they flare the rail and terminal as far from the road as possible and reduce the length of need.

- **Case 18** is used on the trailing end of bridge rail on a one-way roadway. No transition is needed.
- **Case 19 (A and B)** is used where it is not possible to install a post at the 6 foot 3-inch spacing. This design omits one post (resulting in a span of 11 feet 6 inches, which is consistent with a post spacing of 12 feet 6 inches) and uses nested W-beam to stiffen the rail. The cases differ by the location of the splice. No cutting of the rail or offsetting of the splices is needed or desirable.
- **Case 20** is similar to Cases 19A and 19B, except that it allows for two posts to be omitted, which results in a span consistent with post spacing of 18 feet 9 inches.
- **Case 21** has a similar intent as Cases 19A, 19B, and 20 in that it allows for the omission of posts to span an obstruction. This design uses CRT posts with additional post blocks for three posts before and after the omitted posts. The design allows for three posts to be omitted, which results in a span consistent with a post spacing of 25 feet.
- **Case 22** is the “Strong Post Intersection Design” that provides a stiff barrier. This design is to be used as a last resort at crossroads or road approaches where a barrier is needed and there isn’t a clear area behind the nose or minimum distances for a “Weak Post Intersection Design” (see Cases 12 and 13).

**Note:** Some placement cases for use with Beam Guardrail Type 31 are currently under development. As plans become available, they will be housed in the HQ Design Standards (Plan Sheet Library) until they become Standard Plans ([see www.wsdot.wa.gov/design/standards/plansheet](http://www.wsdot.wa.gov/design/standards/plansheet)).

### 1610.07 Cable Barrier

Cable barrier is a flexible barrier system that can be used on a roadside or as a median barrier. It is used primarily in medians and is preferred for many installations due in part to its high benefit-to-cost ratio. Some of the advantages of cable barrier are:

- It provides effective vehicle containment and redirection while imposing the lowest deceleration forces on the vehicle’s occupant(s).
- It may reduce the severity of collisions, which is of significant importance on high-speed facilities.
- After it is struck, it has a tendency not to redirect vehicles back into traffic, which can help reduce the frequency of secondary collisions.
- It can often be placed on existing facilities without the delay of extended environmental permitting and the expense of complex highway reconstruction that might be needed for other barrier system choices.
- It has advantages in heavy snowfall areas because it has minimal potential to create snowdrifts.
- In crucial wildlife habitats, it can aid in some types of animal movements.
- It does not present a visual barrier, which may make it desirable on Scenic Byways (see [1610.05](#)).
- The effort (time and materials) needed to maintain and repair cable barrier systems is much less than the effort needed for a W-beam system.

Deflection is a consideration in narrower median areas and in many urban and other limited-width situations. Use of cable barrier in these situations may not be possible or may require special designs.



For new installations, use four-cable high-tension cable barrier systems, which are available from several manufacturers.

### 1610.07(1) High-Tension Cable Barrier Placement

For typical median applications with slopes between 10H:1V and 6H:1V, the following apply when using single runs of cable barrier (see [Exhibit 1610-13a](#)):

- Cable barrier may be installed in the centerline of the ditch.
- Cable barrier can be offset from the ditch centerline no more than 1 foot (left or right).
- Avoid installing cable barrier within a 1-foot to 8-foot offset from the ditch centerline.
- When locating cable barrier between an 8-foot offset from the ditch centerline and the slope breakpoint, place the cable barrier as far from the edge of traveled way as practicable. Provide a minimum placement distance of 8 feet to the edge of traveled way to allow vehicles to use this area for refuge (see [Exhibit 1610-13a](#)).
- For median shoulder applications, place the cable barrier as far from the edge of traveled way as practicable. Maintain a minimum of 8 feet of usable shoulder width between the edge of traveled way and the face of the cable barrier system (see [Exhibit 1610-13a](#)).

**Note:** [Exhibit 1610-13a](#) shows typical median placement criteria for single runs of cable barrier. Additional placement cases are shown in the WSDOT *Standard Plans*. For non-typical installations, such as double runs of cable barrier or median ditch cross sections that differ significantly from those shown, contact the HQ Design Office for guidance.

- In some situations with cable barrier installations in medians, it is advantageous to terminate a run on one side of the median and begin an adjacent run on the opposite side. In this type of application, it is important to provide adequate cable barrier over-lap distance between the two runs. For placement guidance, see [Exhibit 1610-13c](#).

Narrow medians provide little space for maintenance crews to repair or reposition the barrier. Wherever site conditions permit, provide at least 14 feet of clearance from the adjacent lane edge to the cable barrier.

For typical non-median shoulder applications (see [Exhibit 1610-13b](#)), the following apply:

- Place the cable barrier as far from the edge of traveled way as practicable.
- For shoulder widths less than 8 feet, see [1610.05\(2\)](#) for further guidance.
- Install cable between slope breakpoints as shown in [Exhibit 1610-13b](#).
- Install cable barrier on slopes that are 6H:1V or flatter.
- Cable barrier can be installed up to 1 foot in front of slope breakpoints as steep as 2H:1V.

**Note:** There are approved high-tension cable barrier systems that can be placed on slopes as steep as 4H:1V. The use of these systems requires special placement considerations. Contact the HQ Design Office for guidance when selecting these systems.

### 1610.07(2) High-Tension Cable Barrier Deflection Distances

Depending on the system and post spacing, deflection distances for high-tension barrier systems may range from approximately 6 to 12 feet. Specify the maximum allowable deflection distance in the contract documents. (See Exhibits [1610-13a](#) and [13b](#) for placement details.)

*Note:* There are new high-tension cable barrier systems under development that may change selection and placement criteria. The HQ Design Office will circulate guidance on these new developments as they are adopted as WSDOT policy.

### **1610.07(3) High-Tension Cable Barrier Termination**

- It is possible to terminate high-tension cable barrier systems by connecting directly to beam guardrail runs that are rigidly anchored (such as transitions to bridge rails) and also to a separate anchorage system. Designers should review field conditions, check local maintenance personnel needs, and then specify the required connection option in the contract documents. If a separate anchorage system is used, refer to [Exhibit 1610-13c](#) for placement guidance.
- When cable barrier is to be connected to a more rigid barrier, a transition section is typically needed. Contact the HQ Design Office for further details.

### **1610.07(4) High-Tension Cable Barrier Height Criteria**

Select a high-tension four-cable barrier system with a height to the center of the top cable of not less than 35 inches and a height to the center of the bottom cable not greater than 19 inches.

### **1610.07(5) High-Tension Cable Barrier Curb Placement**

Avoid the placement of curb in conjunction with high-tension cable barrier systems. Currently, there are no known acceptable cable barrier systems that have been successfully crash tested with this feature present.

*Note:* There are high-tension cable barrier systems under development that may change selection and placement criteria. The HQ Design Office will circulate guidance on these new developments as they are adopted as WSDOT policy.

## **1610.08 Concrete Barrier**

General Considerations:

- Concrete barriers are rigid, rigid anchored, or unrestrained rigid systems. Commonly used in medians, they are also used as shoulder barriers. These systems are stiffer than beam guardrail or cable barrier, and impacts with these barriers tend to be more severe.
- Light standards mounted on top of concrete median barrier must not have breakaway features. (See the concrete barrier light standard section in the [Standard Plans](#).)
- When concrete barrier is considered for use in areas where drainage and environmental issues (such as stormwater, wildlife, or endangered species) might be adversely impacted, contact the HQ Hydraulics Office and the appropriate environmental offices for guidance.

### 1610.08(1) Concrete Barrier Shapes

Concrete barriers use a single-slope or safety shape (New Jersey or F-Shape) to redirect vehicles while minimizing vehicle vaulting, rolling, and snagging. A comparison of these barrier shapes is shown in [Exhibit 1610-7](#).

The single-slope barrier face is the recommended option for embedded rigid concrete barrier applications.

**Note:** There are new precast concrete barrier systems under development that may change future selection and placement criteria. The HQ Design Office will circulate guidance on these new developments as they are adopted as WSDOT policy.

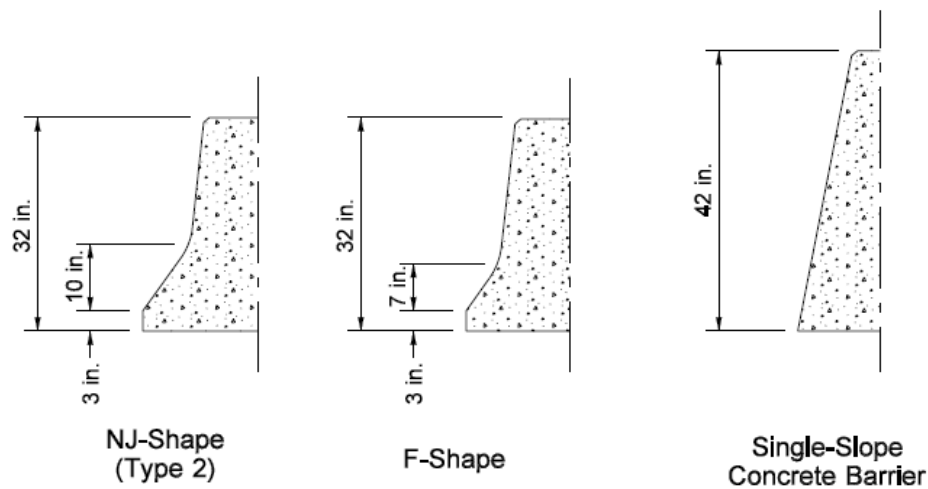

#### Concrete Barrier Shapes

*Exhibit 1610-7*

When the single-slope or F-Shape face is used on structures, and precast barrier is selected for use on the approaches, a cast-in-place transition section is needed so that no vertical edges of the barrier are exposed to oncoming traffic. For details on bridge rail designs, see the [Bridge Design Manual](#).

For aesthetic reasons, avoid changes in the shape of the barrier face within a project or corridor.

The New Jersey shape and F-shape barriers are commonly referred to as “safety shapes.” The New Jersey shape and F-shape have an initial overall height of 32 inches. This height includes provision for up to a 3-inch future pavement overlay that can reduce the barrier height to 29 inches minimum.

#### 1610.08(1)(a) New Jersey Shape Barrier

The New Jersey shape face is primarily used on precast concrete barrier.

Concrete barrier Type 2 (see the [Standard Plans](#)) is a precast barrier that has the New Jersey shape on two sides and can be used for both median and shoulder installations.

The cost of precast Type 2 barrier is significantly less than the cost of the cast-in-place barriers. Therefore, consider the length of the barrier run and the deflection needs to determine whether transitioning to precast Type 2 barrier is desirable. If precast Type 2 barrier is used for the majority of a project, use the New Jersey face for small sections that need cast-in-place barrier, such as for a light standard section.

Concrete barrier Type 4 is also a precast, single-faced New Jersey shape barrier. These units are not freestanding and are to be placed against a rigid structure or anchored to the pavement. If Type 4 barriers are used back to back, consider filling any gap between them to prevent tipping.

Concrete barrier Type 5 is a precast barrier that has a single New Jersey face and is intended for use at bridge ends where the flat side is highly visible. Both Type 2 and Type 5 designs are freestanding, unanchored units connected with steel pins through wire rope loops. For permanent installation, this barrier is placed on a paved surface and a 2-foot-wide paved surface is provided beyond the barrier for its displacement during impact (see [Chapter 1230](#)).

Precast barrier can be anchored where a more rigid barrier is needed. (Anchoring methods are shown in the *Standard Plans*.) The Type 1 and Type 2 anchors are for temporary installations on a rigid pavement. Type 3 anchors can be used in temporary or permanent installations on an asphalt pavement. Consult the HQ Bridge and Structures Office for details when anchoring permanent precast concrete barrier to a rigid pavement.

Precast barrier used on the approach to bridge rail is to be connected to the bridge rail by installing wire rope loops embedded 1 foot 3 inches into the bridge rail with epoxy resin.

Place unrestrained (unanchored) precast concrete barrier on foundation slopes of 5% or flatter. In difficult situations, a maximum slope of 8% may be used. Keep the slope of the area between the edge of the shoulder and the face of the traffic barrier as flat as possible. The maximum slope is 10H:1V (10%).

#### **1610.08(1)(b) Single-Slope Barrier**

The single-slope concrete barrier can be cast in place, slipformed, or precast. The most common construction technique for this barrier has been slipforming, but some precast single-slope barrier has been installed. The primary benefit of using precast single-slope barrier is that it can be used as temporary barrier during construction and then reset into a permanent location. In temporary applications, the single-slope barrier may also offer the added benefits of reducing headlight glare and providing reduced deflection characteristics over some other barrier types.

Single-slope barrier is considered a rigid system regardless of the construction method used. For new installations, the minimum height of the barrier above the roadway is 2 feet 10 inches, which allows a 2-inch tolerance for future overlays. The minimum total height of the barrier section is 3 feet 6 inches, with a minimum of 3 inches embedded in the roadway wearing surface. This allows for use of the 3-foot-6-inch barrier between roadways with grade separations of up to 5 inches. A grade separation of up to 10 inches is allowed when using a 4-foot-6-inch barrier section, as shown in the *Standard Plans*. The barrier is to have a depth of embedment equal to or greater than the grade separation. Contact the HQ Bridge and Structures Office for grade separations greater than 10 inches.

**1610.08(1)(c) Low-Profile Barrier**

Low-profile barrier designs are available for median applications where the posted speed is 45 mph or below. These barriers are normally used in urban areas. They are typically 18 to 20 inches high and offer sight distance benefits. For barrier designs, terminals, and further details, contact the HQ Design Office.

**1610.08(2) High-Performance Concrete Barrier**

High-Performance Concrete Barrier (HP Barrier) is a rigid barrier with a minimum height of 42 inches above the roadway surface. This barrier is designed to function more effectively during heavy-vehicle collisions. This taller barrier may also offer the added benefits of reducing headlight glare and reducing noise in surrounding environments. HP Barrier is generally considered single-slope barrier. (See the *Standard Plans* for barrier details.) For additional available shapes, contact the HQ Design Office.

For new/reconstruction, use HP Barrier in freeway medians of 22 feet or less. Also, use HP Barrier on Interstate or freeway routes where accident history suggests a need or where roadway geometrics increase the possibility of larger trucks hitting the barrier at a high angle (for example, on-ramps for freeway-to-freeway connections with sharp curvature in the alignment).

Consider the use of HP Barrier at other locations such as nonfreeway narrow medians, near highly sensitive environmental areas, near densely populated areas, over or near mass transit facilities, or on vertically divided highways.

**1610.08(3) Concrete Barrier Terminals**

Whenever possible, bury the end of the concrete barrier in the backslope. The backslope needed to bury the end is to be 3H:1V or steeper and at least 4 feet in height above the roadway. Flare the concrete barrier into the backslope using a flare rate that meets the criteria in 1610.05(4). Provide a 10H:1V or flatter foreslope into the face of the barrier and maintain the full barrier height to the foreslope/backslope intersection. This might create the need to fill ditches and install culverts in front of the barrier face.

The 7-foot-long precast concrete terminal end section for concrete barrier Type 2 and the 10- to 12-foot single-slope barrier terminal may be used:

- Outside the Design Clear Zone.
- On the trailing end of the barrier when it is outside the Design Clear Zone for opposing traffic.
- On the trailing end of one-way traffic.
- Where the posted speed is 25 mph or below.

Another available end treatment for Type 2 barriers is a precast or cast-in-place tapered terminal section with a minimum length of 48 feet and a maximum length of 80 feet. It is used infrequently for special applications and is designed to be used for posted speeds of 35 mph or below. For details, contact the HQ Design Office or refer to the Plan Sheet Library: [www.wsdot.wa.gov/design/standards/plansheet/](http://www.wsdot.wa.gov/design/standards/plansheet/)

When the “Barrier Terminals and Transitions” column of a Design Matrix applies to a project, existing sloped-down concrete terminals that are within the Design Clear Zone are to be replaced when they do not meet the above criteria.

When the end of a concrete barrier cannot be buried in a backslope or terminated as described above, terminate the barrier using a guardrail terminal and transition or an impact attenuator (see Chapter 1620).

**1610.08(4) Assessing Impacts to Wildlife**

The placement of concrete barriers in locations where wildlife frequently cross the highway can influence traffic safety and wildlife mortality. When wildlife encounter physical barriers that are difficult to cross, they often travel parallel to those barriers. With traffic barriers, this means that they often remain on the highway for a longer period, increasing the risk of wildlife/vehicle collisions or vehicle/vehicle collisions as motorists attempt avoidance.

Traffic-related wildlife mortality may play a role in the decline of some species listed under the Endangered Species Act. To address public safety and wildlife concerns, see Exhibit 1610-8 to assess whether concrete barrier placement needs to have an evaluation by the HQ Environmental Services Office to determine its effect on wildlife. Conduct this evaluation early in the project development process to allow adequate time for discussion of options.

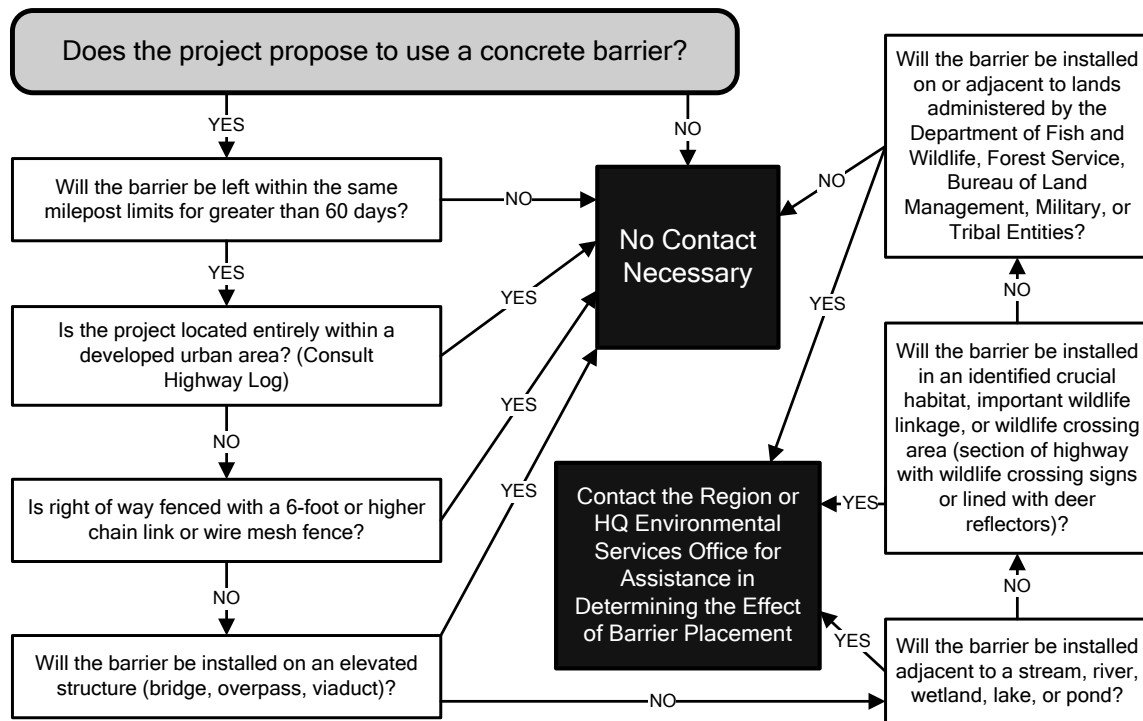

**Concrete Barrier Placement Guidance: Assessing Impacts to Wildlife**  
Exhibit 1610-8

**1610.08(5) Assessing Impacts to Stormwater and Wetlands**

In locations where medians or roadsides are used for drainage, the retention of stormwater or the existence of wetlands can influence the choice and use of barrier systems. For example, the placement of concrete barrier and beam guardrail in many of these cases may create the need for additional impervious material, which can result in complete retrofit and reconstruction of the existing systems. When water is drained, stored, or treated, and where wetlands exist, the ability to provide alternative facilities that replace the functions of the existing ones may be nonexistent or prohibitively expensive to provide elsewhere.

To address public safety, stormwater, and wetland concerns, assess whether concrete barrier or beam guardrail placement will cause the need for an evaluation by the HQ Environmental Services Office. Conduct this evaluation early in the project development process to allow adequate time for discussion of options.

### 1610.09 Special-Use Barriers

The following barriers may be used on designated Scenic Byway and Heritage Tour routes if funding can be arranged (see [1610.05](#) and [Chapter 120](#)).

#### 1610.09(1) *Steel-Backed Timber Guardrail*

Steel-backed timber guardrails consist of a timber rail with a steel plate attached to the back to increase its tensile strength. There are several variations of this system that have passed crash tests. The nonproprietary systems use a beam with a rectangular cross section that is supported by either wood or steel posts. A proprietary (patented) system called the Ironwood Guardrail is also available. This system uses a beam with a round cross section and is supported by steel posts with a wood covering to give the appearance of an all-wood system from the roadway.

The Ironwood Guardrail can be allowed as an alternative to the nonproprietary system. However, specifying this system exclusively needs approval by an Assistant State Design Engineer of a public interest finding for the use of a sole source proprietary item.

The most desirable method of terminating the steel-backed timber guardrail is to bury the end in a backslope, as described in [1610.06\(5\)](#). When this type of terminal is not possible, use of the barrier is limited to highways with a posted speed of 45 mph or below. On these lower-speed highways, the barriers can be flared away from the traveled way and terminated in a berm outside the Design Clear Zone.

For details on these systems, contact the HQ Design Office.

#### 1610.09(2) *Stone Guardwalls*

Stone guardwalls function like rigid concrete barriers but have the appearance of natural stone. These walls can be constructed of stone masonry over a reinforced concrete core wall or of simulated stone concrete. These types of barriers are designed to have a limited projection of the stones to help aid in the redirection characteristics of the barrier. The most desirable method of terminating this barrier is to bury the end in a backslope, as described in [1610.08\(3\)](#). When this type of terminal is not possible, use of the barrier is limited to highways with a posted speed of 45 mph or below. On these lower-speed highways, the barrier can be flared away from the traveled way and terminated in a berm outside the Design Clear Zone.

For details on these systems, contact the HQ Design Office.

### 1610.10 Bridge Traffic Barriers

Bridge traffic barriers redirect errant vehicles and help to keep them from going over the side of the structure. (See the [Bridge Design Manual](#) for information regarding bridge barrier on new bridges and replacement bridge barrier on existing bridges.)

For new bridge rail installations, use a 2-foot-10-inch-high single-slope or a 2 foot-8-inch-high safety shape (F Shape) bridge barrier. A transition is available to connect the New Jersey shape (Type 2 concrete barrier) and the F-Shape bridge barrier. (See the [Standard Plans](#) for further details.)

Use taller 3-foot-6-inch single-slope or safety shape bridge barriers on Interstate or freeway routes where accident history suggests a need or where taller barrier is required on approaching roadways with narrow medians, as defined in [1610.08\(2\)](#). Also, consider taller 3-foot-6-inch barrier when geometrics increase the possibility of larger trucks hitting the barrier at a high angle (such as on-ramps for freeway-to-freeway connections with sharp curvature in the alignment).

For further guidance on bridges where high volumes of pedestrian traffic are anticipated, see Chapters [720](#), [1510](#), [1515](#), and [1520](#).

Approach barriers, transitions, and connections are usually needed on all four corners of bridges carrying two-way traffic and on both corners of the approach end for one-way traffic. (See [1610.06\(6\)](#) for guidance on transitions.)

If the bridge barrier system does not meet the criteria for strength and geometrics, modifications to improve its redirection characteristics and its strength may be needed. The modifications can be made using one of the retrofit methods described in [1610.10\(1\)](#) and [1610.10\(2\)](#).

### **1610.10(1) Concrete Safety Shape**

Retrofitting with a new concrete bridge barrier is costly and needs to have justification when no widening is proposed. Consult the HQ Bridge and Structures Office for design details and to determine whether the existing bridge deck and other superstructure elements are of sufficient strength to accommodate this bridge barrier system.

### **1610.10(2) Thrie Beam Retrofit**

Retrofitting with thrie beam is an economical way to improve the strength and redirection performance of bridge barriers. The thrie beam can be mounted to steel posts or the existing bridge barrier, depending on the structural adequacy of the bridge deck, the existing bridge barrier type, the width of curb (if any), and the curb-to-curb roadway width carried across the structure.

The HQ Bridge and Structures Office is responsible for the design of thrie beam bridge barrier. [Exhibit 1610-14](#) shows typical retrofit criteria. Contact the HQ Bridge and Structures Office for assistance with thrie beam retrofit design.

Consider the Service Level 1 (SL-1) system on bridges with wooden decks and for bridges with concrete decks that do not have the needed strength to accommodate the thrie beam system. Contact the HQ Bridge and Structures Office for information needed for the design of the SL-1 system.

A sidewalk reduction of up to 6 inches as a result of a thrie beam retrofit can be documented as a design exception.

The funding source for retrofit of existing bridge rail is dependent on the length of the structure. Bridge rail retrofit, for bridges less than 250 feet in length, or a total bridge rail length of 500 feet, is funded by the project ([Guardrail Preservation or Improvement](#)). For longer bridges, the retrofit will be included in the I-2 Bridge Rail upgrades program. Contact the HQ Program Development Office to determine whether funding is available.



## 1610.11 Other Barriers

### 1610.11(1) Dragnet

The Dragnet Vehicle Arresting Barrier consists of chain link or fiber net that is attached to energy absorbing units. When a vehicle hits the system, the Dragnet brings the vehicle to a controlled stop with limited damage. Possible uses for this device include the following:

- Reversible lane entrances and exits
- Railroad crossings
- Truck escape ramps (instead of arrester beds—see [Chapter 1270](#))
- T-intersections
- Work zones
- Swing span bridges

For permanent installations, this system can be installed between towers that lower the unit into position when needed and lift it out of the way when it is no longer needed. For work zone applications, it is critical to provide deflection space for stopping the vehicle between the system and the work zone. For additional information on the Dragnet, contact the HQ Design Office.

## 1610.12 Documentation

Refer to [Chapter 300](#) for design documentation requirements.

Connecting W-Beam Guardrail to: Transitions and Connections		Transition Type*	Connection	
Bridge Rail	New Installation	20, 21	D	
	Existing Concrete	Concrete Parapet > 20 inches	20, 21, 4 <sup>[4]</sup>	Exhibit 1610-6
		Concrete Parapet < 20 inches	2, 4 <sup>[4]</sup>	Exhibit 1610-6
		Existing W-Beam Transition	2 <sup>[1][5]</sup> , 4 <sup>[4]</sup>	[1]
	Thrie Beam at Face of Curb <sup>[3]</sup>	Approach End	23	n/a
		Trailing End (two-way traffic only)	23	n/a
	Thrie Beam at Bridge Rail (curb exposed) <sup>[3]</sup>	Approach End	22	n/a
		Trailing End (two-way traffic only)	22	n/a
	Weak Post Intersection Design (see 1610.06(7)(b), Cases 12 & 13)		5	Exhibit 1610-6
	Concrete Barrier	Rigid & Rigid Anchored	21	Exhibit 1610-6
Unrestrained		2, 4 <sup>[4]</sup>	A	
Weak Post Barrier Systems (Type 20 and 21)		6	n/a	
Rigid Structures such as Bridge Piers	New Installation (see Cases 11–31)	21	n/a	
	Existing W-Beam Transition	[2]	n/a	
Connecting Thrie Beam Guardrail to:		Transition Type*	Connection	
Bridge Rail or Concrete Barrier	New Installation (example: used with thrie beam bull nose)	1B	Exhibit 1610-6	

\*Consult Section C of the *Standard Plans* for details on transition types.

**Notes:**

- [1] If work creates the need for reconstruction or resetting of the transition, upgrade as shown above. Raising the guardrail is not considered reconstruction. If the transition is not being reconstructed, the existing connection may remain in place. When Type 3 anchors are encountered, see 1610.06(5)(e) for guidance.
- [2] For new/reconstruction, use Case 11 (thrie beam). For existing Case 11 with W-beam, add a second W-beam rail element.
- [3] For Service Level 1 bridge rail, see 1610.06(7)(b), Case 14.
- [4] Use on highways with speeds 45 mph or below.
- [5] If existing transition has the needed guardrail height—three 10" x 10" (nominal) posts and three 6" x 8" (nominal) posts spaced 3'-1.5" apart—it is acceptable to nest existing single W-beam element transitions.

**Transitions and Connections**  
*Exhibit 1610-9*

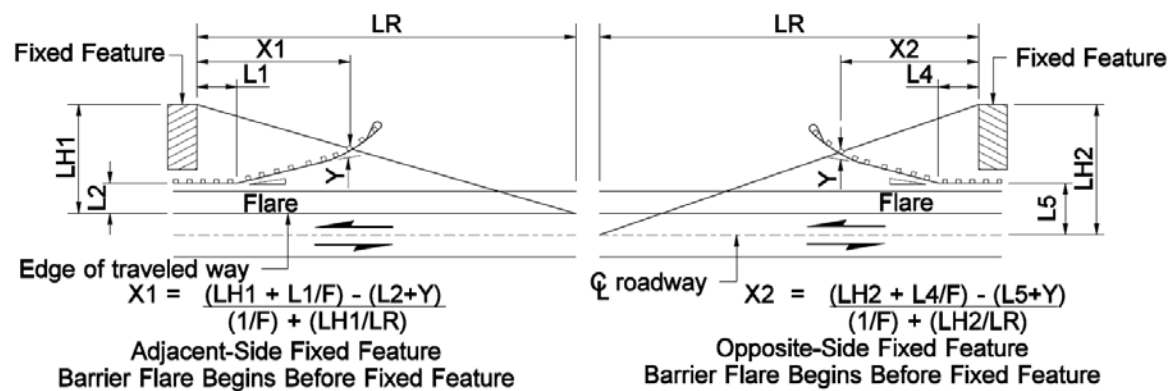
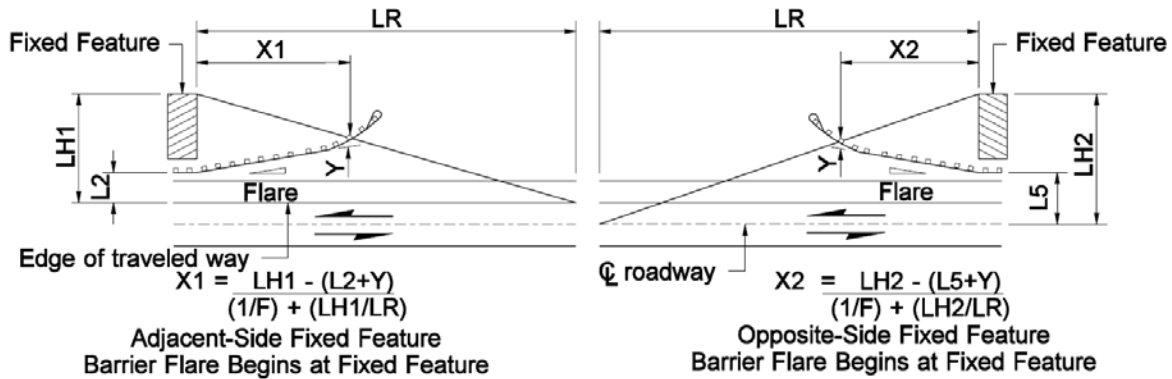
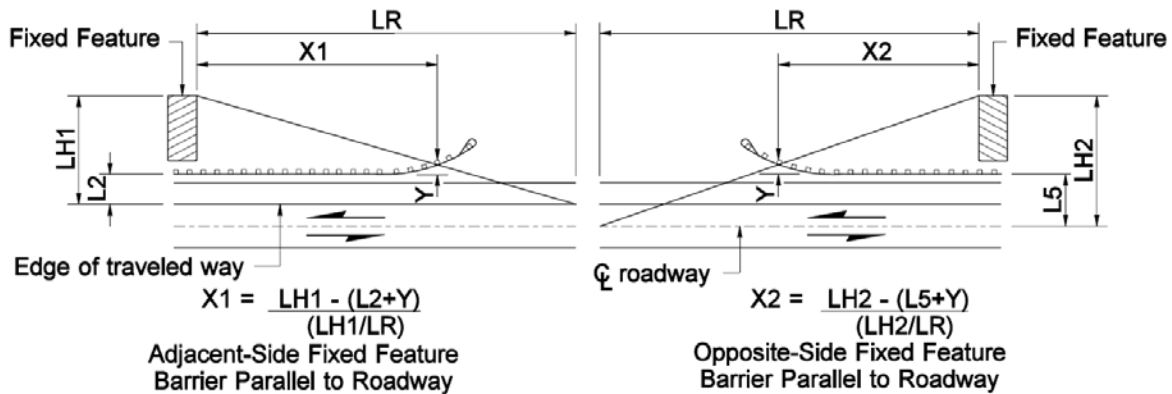

**Note:**

For supporting length of need equation factors, see [Exhibit 1610-10b](#).

**Barrier Length of Need on Tangent Sections**

*Exhibit 1610-10a*

Posted Speed (mph)	Design Parameters						
	ADT				Barrier Type		
	Over 10,000	5,000 to 10,000	1,000 to 4,999	Under 1,000	Rigid & Rigid Anchored Barrier	Rigid Unrestrained Barrier	Semirigid Barrier
	LR (ft)	LR (ft)	LR (ft)	LR (ft)	F	F	F
70	<u>360</u>	<u>330</u>	<u>290</u>	<u>250</u>	20	18	15
<u>65</u>	<u>330</u>	<u>290</u>	<u>250</u>	<u>225</u>	<u>20</u>	<u>18</u>	<u>15</u>
60	<u>300</u>	<u>250</u>	<u>210</u>	<u>200</u>	18	16	14
55	<u>265</u>	<u>220</u>	<u>185</u>	<u>175</u>	16	14	12
50	<u>230</u>	<u>190</u>	<u>160</u>	<u>150</u>	14	12	11
45	<u>195</u>	<u>160</u>	<u>135</u>	<u>125</u>	12	11	10
40	<u>160</u>	<u>130</u>	<u>110</u>	<u>100</u>	11	10	9
35	<u>135</u>	<u>110</u>	<u>95</u>	<u>85</u>	11	10	9
30	<u>110</u>	<u>90</u>	<u>80</u>	<u>70</u>	11	10	9
25	<u>110</u>	<u>90</u>	<u>80</u>	<u>70</u>	11	10	9

- L1 = Length of barrier parallel to roadway from adjacent-side fixed feature to beginning of barrier flare. This is used if a portion of the barrier cannot be flared (such as a bridge rail and the transition).
- L2 = Distance from adjacent edge of traveled way to portion of barrier parallel to roadway.
- L4 = Length of barrier parallel to roadway from opposite-side fixed feature to beginning of barrier flare.
- L5 = Distance from centerline of roadway to portion of barrier parallel to roadway. **Note:** If the fixed feature is outside the Design Clear Zone when measured from the centerline, it may only be necessary to provide a crash-tested end treatment for the barrier.
- LH1 = Distance from outside edge of traveled way to back side of adjacent-side fixed feature. Note: If a fixed feature extends past the Design Clear Zone, the Design Clear Zone can be used as LH1.
- LH2 = Distance from centerline of roadway to back side of opposite-side fixed feature. **Note:** If a fixed feature extends past the Design Clear Zone, the Design Clear Zone can be used as LH2.
- LR = Runout length, measured parallel to roadway.
- X1 = Length of need for barrier to shield an adjacent-side fixed feature.
- X2 = Length of need for barrier to shield an opposite-side fixed feature.
- F = Flare rate value.
- Y = Offset distance needed at the beginning of the length of need.

#### Different end treatments need different offsets:

- For the SRT 350 and FLEAT 350, use Y = 1.8 feet.
- For evaluating existing BCTs, use Y = 1.8 feet.
- For the FLEAT TL-2, use Y = 0.8 feet.
- No offset is needed for the nonflared terminals or impact attenuator systems. Use Y = 0.

#### Barrier Length of Need Exhibit 1610-10b

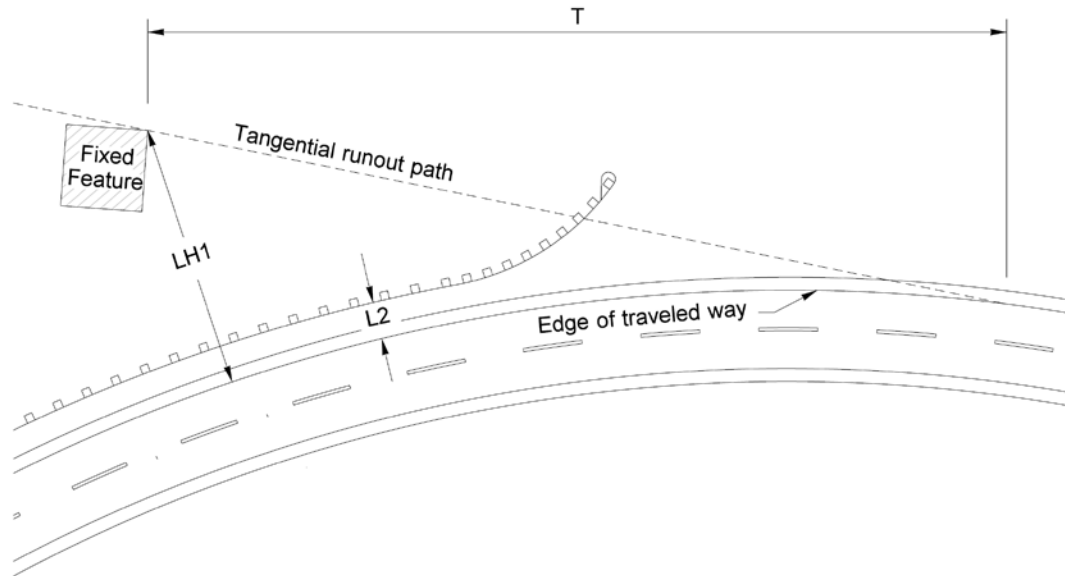

**Notes:**

- This is a graphical method for determining the length of need for barrier on the outside of a curve.
- On a scale drawing, draw a tangent from the curve to the back of the fixed feature. Compare T to LR from [Exhibit 1610-10b](#) and use the shorter value.
- If using LR, follow Exhibits [1610-10a](#) and [10b](#).
- If using T, draw the intersecting barrier run to scale and measure the length of need.

**Barrier Length of Need on Curves**  
*Exhibit 1610-10c*

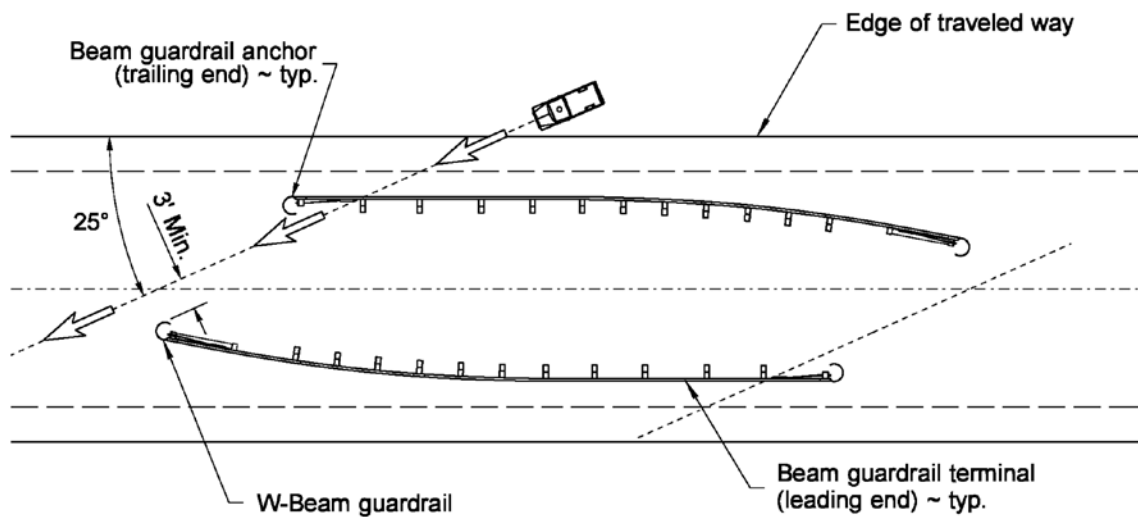

**W-Beam Guardrail Trailing End Placement for Divided Highways**  
*Exhibit 1610-10d*

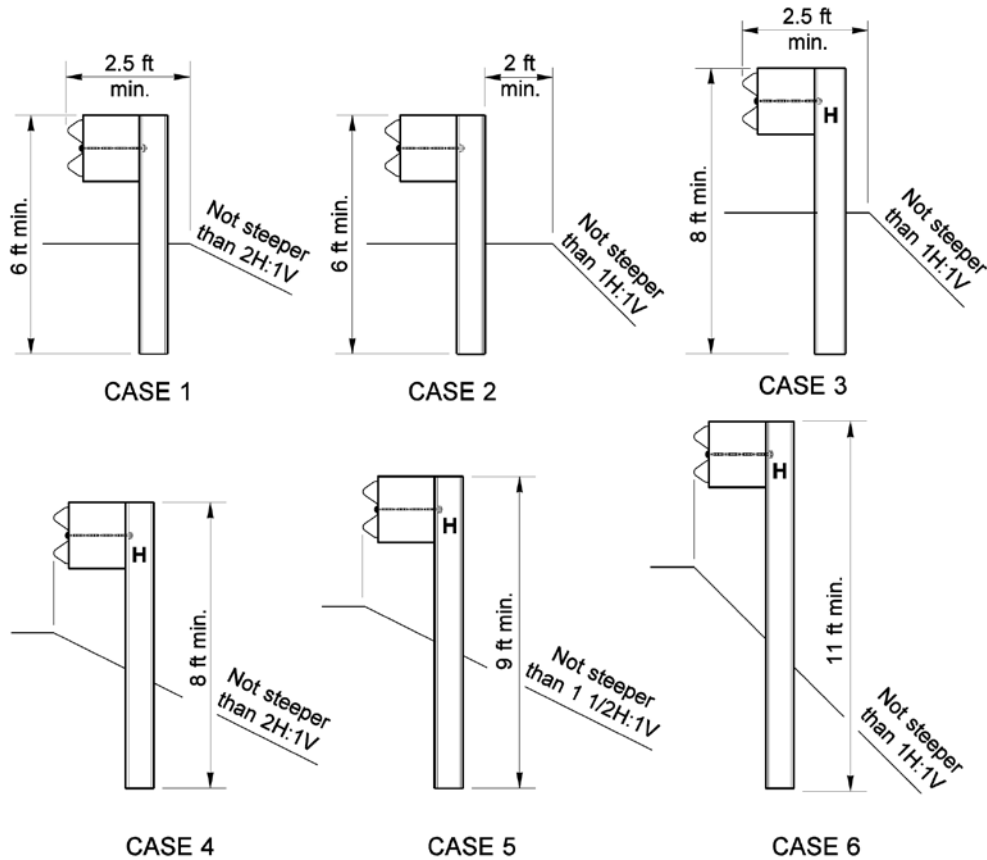

**Type 31 Shown**

**Notes:**

- Use Cases 1 and 3 when there is a 2.5-foot or greater shoulder widening from face of guardrail to the breakpoint.
- Use Case 2 when there is a 4.0-foot or greater shoulder widening from the face of the guardrail to the breakpoint.
- Use Cases 4, 5, and 6 when there is less than a 2.5-foot shoulder widening from face of guardrail to the breakpoint.

**Beam Guardrail Post Installation**  
*Exhibit 1610-11*

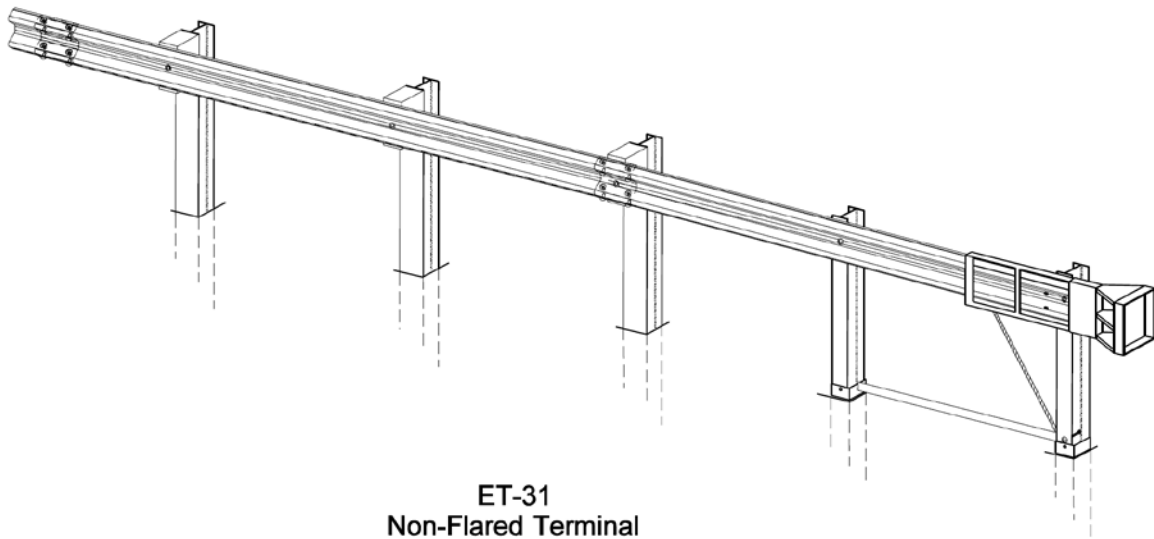
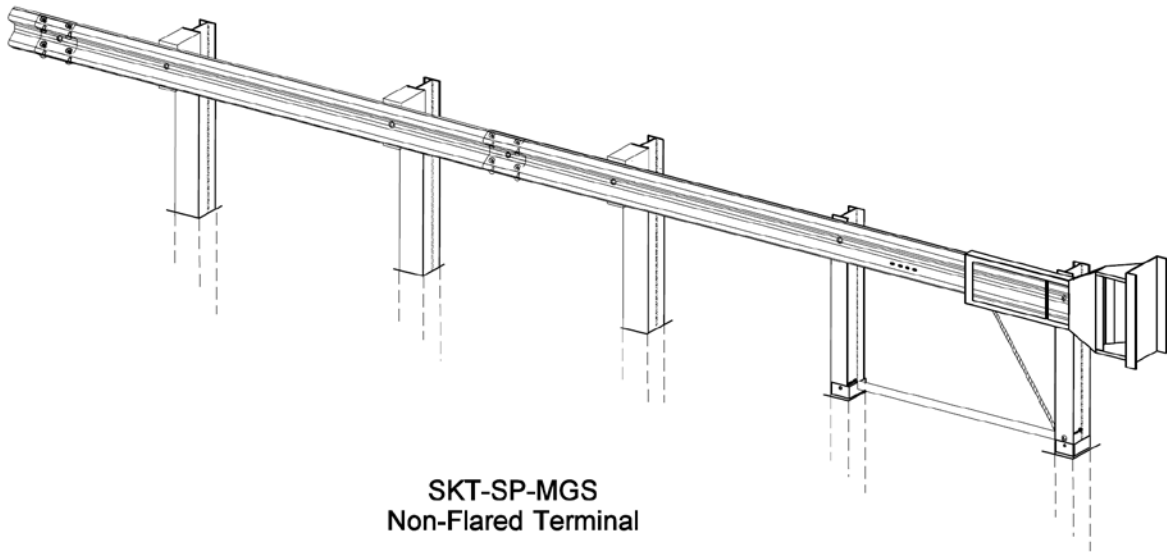

**Beam Guardrail Terminals**  
*Exhibit 1610-12a*

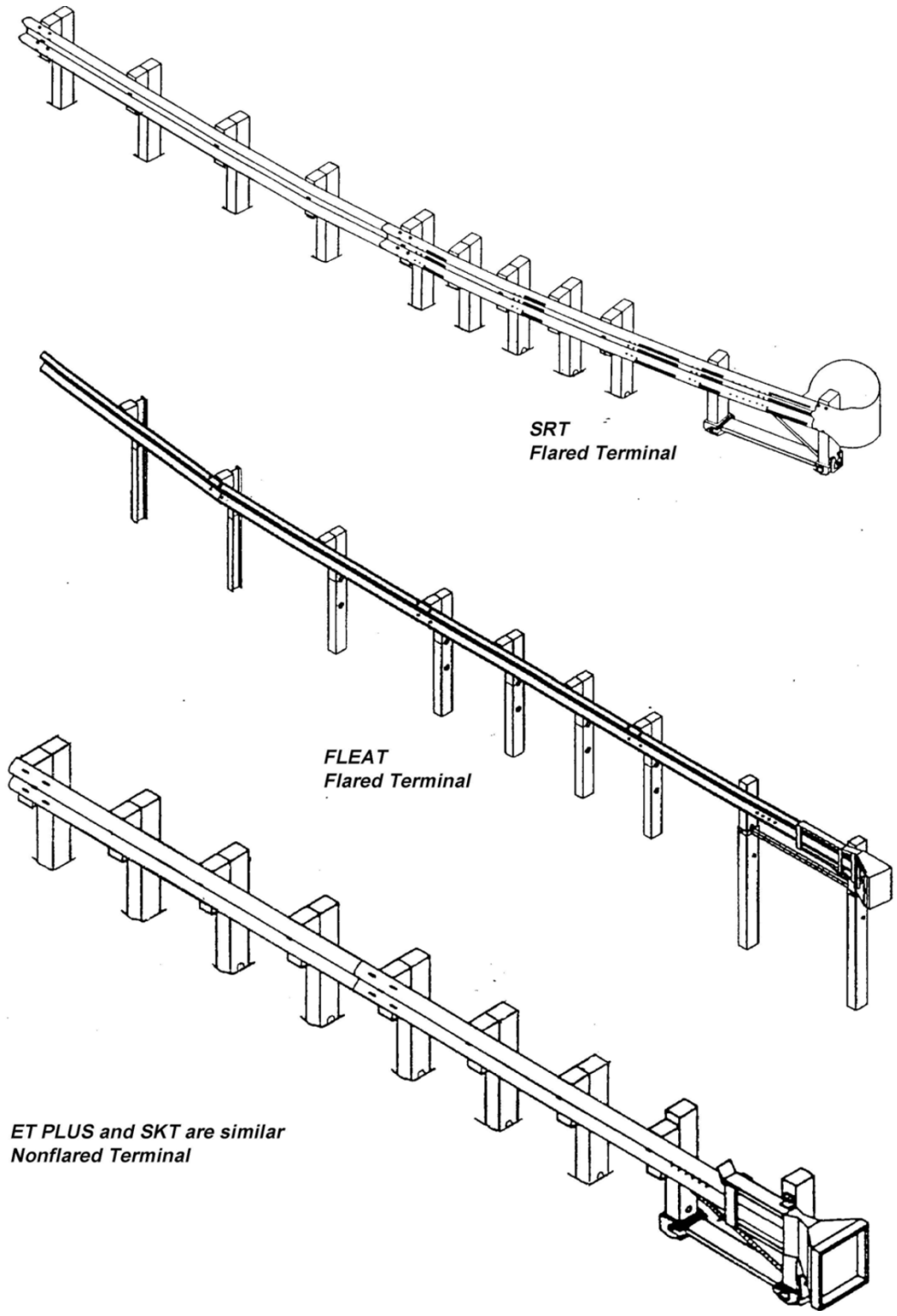

**Beam Guardrail Terminals**  
*Exhibit 1610-12b*



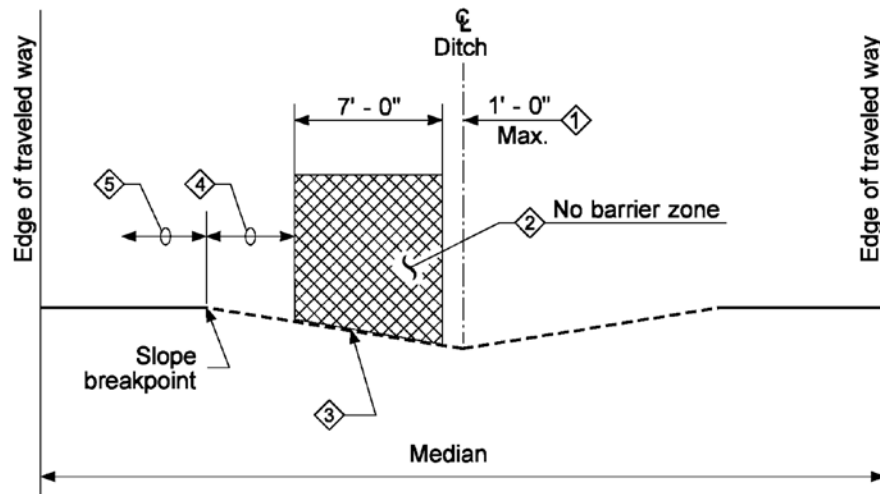

Median Placement - Left

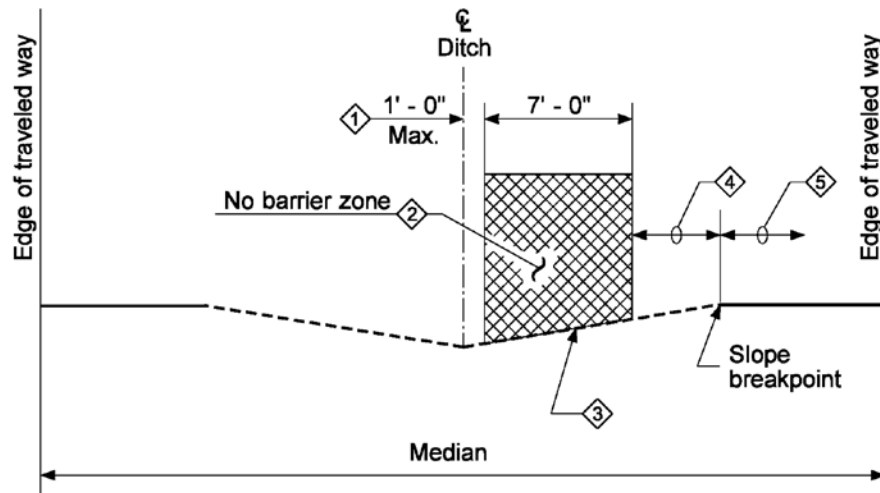

Median Placement - Right

**Notes:**

- 1 Cable barrier may be installed in the center of the ditch and from the ditch centerline a maximum of 1 foot (left or right).
- 2 Avoid installing cable barrier within a 1-foot to 8-foot offset from the ditch centerline.
- 3 Applies to slopes between 10H:1V and 6H:1V.
- 4 Slope Installation: Install cable barrier between an 8-foot offset from the ditch centerline and the slope breakpoint. Provide a maximum deflection distance of 8 feet to the edge of traveled way.
- 5 Shoulder Installation: For median shoulder applications, maintain a minimum of 8 feet of usable shoulder width between the edge of traveled way and the face of the cable barrier system.

**Single Cable Barrier Placement Locations on Median Slopes***Exhibit 1610-13a*

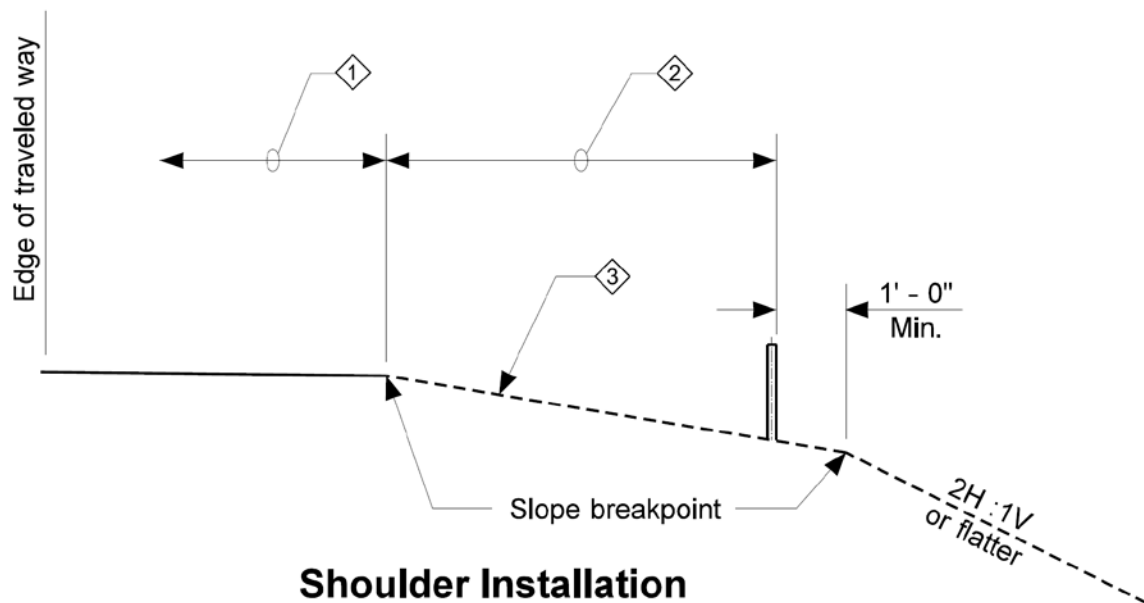

**Notes:**

- ① For shoulder widths less than 8 feet, see [1610.05\(2\)](#) for further guidance.
- ② Slope Installation: Install cable barrier relative to the slope breakpoints within the limits shown.
- ③ Applies to slopes that are 6H:1V or flatter.

**Cable Barrier Locations on Shoulder Slopes**  
*Exhibit 1610-13b*

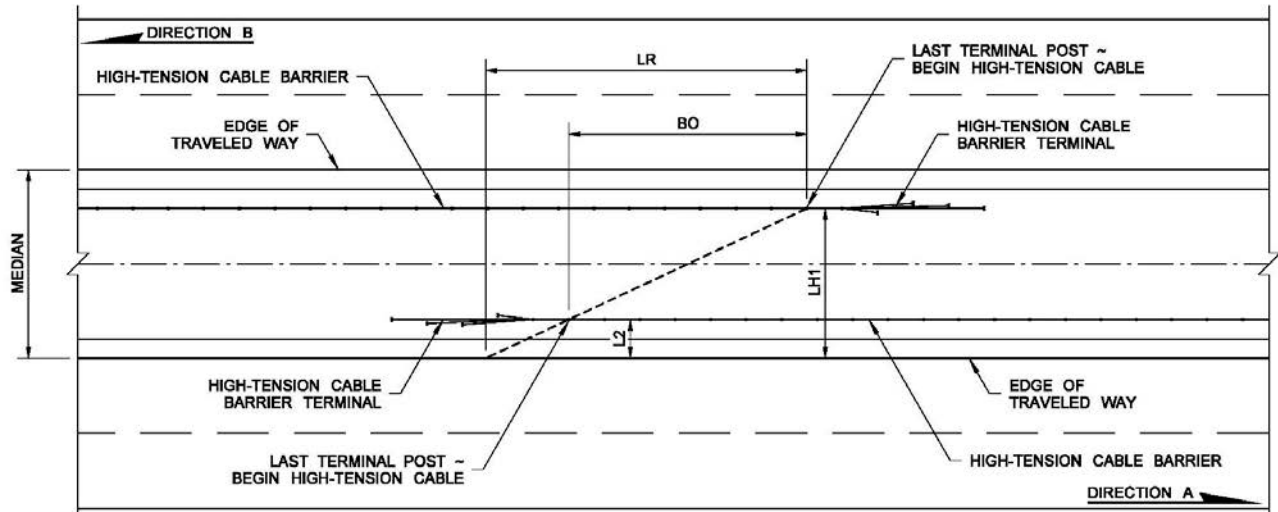

**Cable Barrier Median Overlap**

$$BO = \frac{LH1 - L2}{LH1/LR} \quad (\text{Direction A shown})$$

**Note:**

Calculate barrier overlap (BO) from both directions of travel. Use the greatest value of BO obtained.

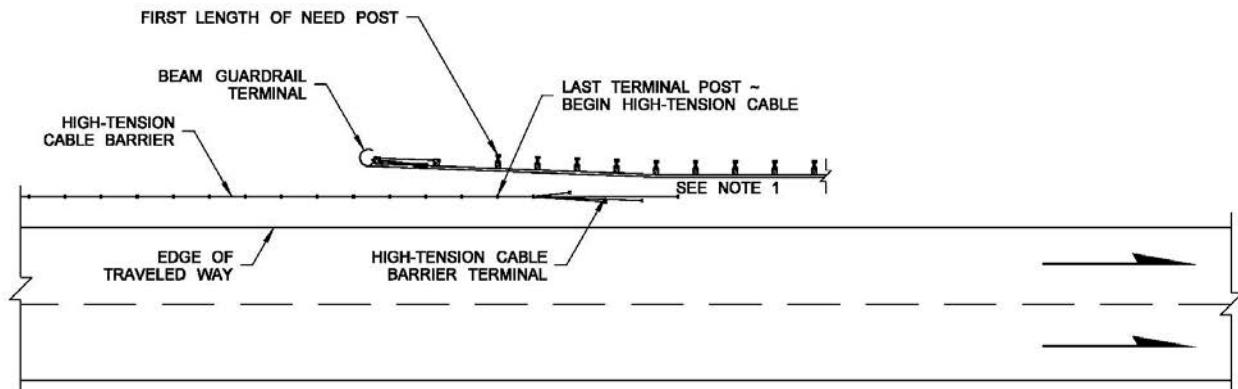

**Cable Barrier Overlap With Beam Guardrails**

**Notes:**

- [1] The beam guardrail may need to be extended and flared to maintain adequate barrier overlap and shoulder width.
- [2] Typical applications may be at bridge transitions or where high-tension cable and beam guardrail systems end or begin.
- [3] For supporting length of need equation factors, see [Exhibit 1610-10b](#).

**Cable Barrier Placement for Divided Highways**  
*Exhibit 1610-13c*

Curb Width	Bridge Width	Concrete Bridge Deck		Wood Bridge Deck or Low-Strength Concrete Deck
		Concrete Bridge Rail (existing)	Steel or Wood Post Bridge Rail (existing)	
<18 inches		Thrie beam mounted to existing bridge rail <sup>[2]</sup> and blocked out to the face of curb. Height = 32 inches	Thrie beam mounted to steel posts <sup>[2]</sup> at the face of curb. Height = 32 inches	<ul style="list-style-type: none"> <li>• Service Level 1 Bridge Rail<sup>[2]</sup></li> <li>• Height = 32 inches</li> <li>• Curb or wheel guard needs to be removed</li> </ul>
>18 inches	> 28 ft (curb to curb)	Thrie beam mounted to steel posts <sup>[2]</sup> at the face of curb. <sup>[1]</sup> Height = 32 inches		
>18 inches	< 28 ft (curb to curb)	Thrie beam mounted to existing bridge rail. <sup>[2]</sup> Height = 35 inches	Thrie beam mounted to steel posts <sup>[2]</sup> in line with existing rail. Height = 35 inches	

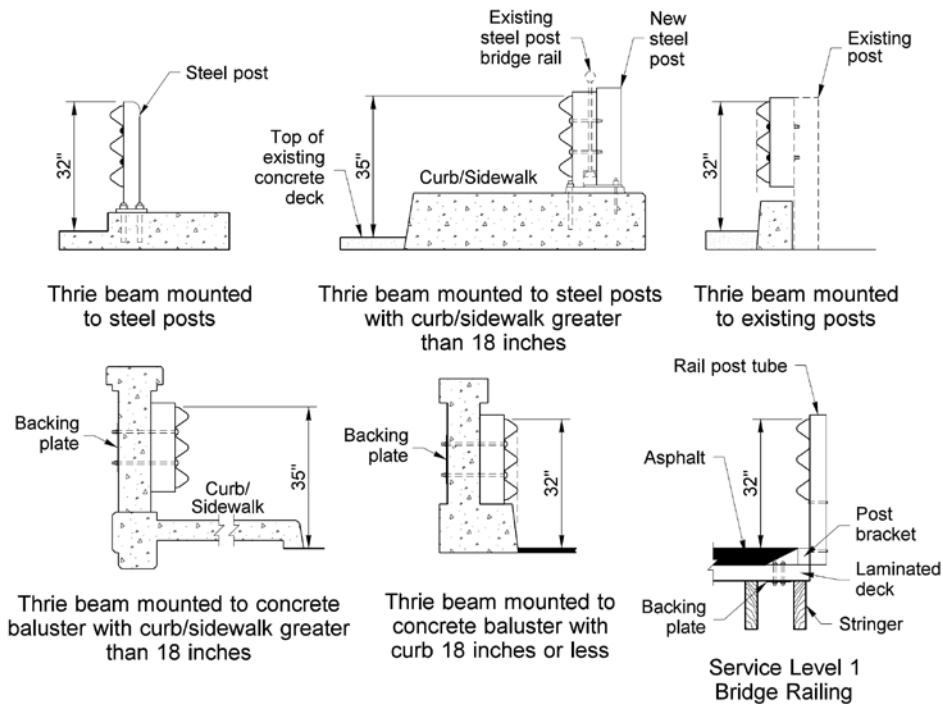

**Notes:**

- [1] To maximize available curb/sidewalk width for pedestrian use, thrie beam may be mounted to the bridge rail at a height of 35 inches.
- [2] Contact the HQ Bridge and Structures Office for design details on bridge rail retrofit projects.

**Thrie Beam Rail Retrofit Criteria**  
*Exhibit 1610-14*

[Acronyms](#)

[ADA / Pedestrian Terms](#)

[Main Glossary of Terms](#)

# Acronyms

---

<b>AADT</b>	Annual average daily traffic	<b>HSS</b>	Highways of Statewide Significance
<b>ACCT</b>	Agency Council on Coordinated Transportation	<b>ICA</b>	Intersection Control Analysis
<b>ADA</b>	Americans with Disabilities Act of 1990	<b>ICD</b>	Inscribed circle diameter
<b>ADT</b>	Annual daily traffic	<b>IJR</b>	Interchange Justification Report
<b>ADT</b>	Average daily traffic	<b>ISTEA</b>	Intermodal Surface Transportation Efficiency Act of 1991
<b>ALJ</b>	Administrative law judge	<b>ITS</b>	Intelligent transportation systems
<b>AOS</b>	Apparent opening size	<b>L/A</b>	Limited access
<b>APS</b>	Accessible pedestrian signal	<b>LOS</b>	Level of service
<b>ARB</b>	Agency Request Billing	<b>MEF</b>	Maximum extent feasible
<b>AWDVTE</b>	Average weekday vehicle trip ends	<b>MOU</b>	Memorandum of Understanding
<b>BAT</b>	Business access transit	<b>MPO</b>	Metropolitan Planning Organization
<b>B/C</b>	Benefit/Cost	<b>MTIP</b>	Metropolitan Transportation Improvement Program
<b>BLM</b>	Bureau of Land Management	<b>MUTCD</b>	Manual on Uniform Traffic Control Devices
<b>BRT</b>	Bus rapid transit	<b>NEPA</b>	National Environmental Policy Act
<b>BST</b>	Bituminous surface treatment	<b>NHS</b>	National Highway System
<b>CE</b>	Categorical Exemption (SEPA)	<b>PAR</b>	Pedestrian access route
<b>CE</b>	Categorical Exclusion (NEPA)	<b>PATS</b>	Priority Array Tracking System
<b>CFR</b>	Code of Federal Regulations	<b>PC&amp;R</b>	Project Control and Reporting
<b>CIPP</b>	Capital Improvement and Preservation Program	<b>PCPH</b>	Passenger cars per hour
<b>CLB</b>	Current Law Budget	<b>PD</b>	Project Definition
<b>CMP</b>	Corridor Management Plan	<b>PE</b>	Preliminary engineering
<b>CPMS</b>	Capital Program Management System	<b>PF</b>	Project File
<b>CRT</b>	Controlled releasing terminal post	<b>PPH</b>	Persons per hour
<b>CSS</b>	Context sensitive solutions	<b>PS</b>	Project Summary
<b>CTR</b>	Commute Trip Reduction	<b>PS&amp;E</b>	Plans, Specifications, and Estimates
<b>CVISN</b>	Commercial Vehicle Inf. System and Networks	<b>PSRC</b>	Puget Sound Regional Council
<b>DCE</b>	Documented Categorical Exclusion (NEPA)	<b>RCW</b>	Revised Code of Washington
<b>DD</b>	Design Decisions	<b>RFP</b>	Request for Proposal
<b>DE</b>	Design exception	<b>ROD</b>	Record of Decision
<b>DDHV</b>	Directional design hour volume	<b>RTID</b>	Regional Transportation Investment District
<b>DDP</b>	Design Documentation Package	<b>RTIP</b>	Regional Transportation Improvement Program
<b>DHV</b>	Design hourly volume	<b>RTPO</b>	Regional Transportation Planning Organization
<b>DNS</b>	Determination of Nonsignificance (SEPA)	<b>RV</b>	Recreational vehicle
<b>DS</b>	Determination of Significance (SEPA)	<b>R/W</b>	Right of way
<b>DVI</b>	Design Variance Inventory	<b>SEPA</b>	[Washington] State Environmental Policy Act
<b>DVIS</b>	Design Variance Inventory System	<b>SIMMS</b>	Signal Maintenance Management System
<b>EA</b>	Environmental Assessment (NEPA)	<b>SOV</b>	Single-occupant vehicle
<b>ECS</b>	Environmental Classification Summary	<b>SRA</b>	Safety rest area
<b>E&amp;EP</b>	Environmental & Engineering Programs Division	<b>STIP</b>	Statewide Transportation Improvement Program
<b>EIS</b>	Environmental Impact Statement	<b>STP</b>	Surface Transportation Program
<b>ERS</b>	Environmental Review Summary	<b>TIP</b>	Transportation Improvement Program
<b>EU</b>	Evaluate upgrade	<b>TMA</b>	Transportation Management Area
<b>FAST</b>	Freight Action Strategy	<b>TMP</b>	Transportation management plan
<b>FGTS</b>	Freight and Goods Transportation System	<b>TRIPS</b>	Transportation Information and Planning Support
<b>FHWA</b>	Federal Highway Administration	<b>TWLT</b>	Two-way left-turn lane
<b>FONSI</b>	Finding of No Significant Impact (NEPA)	<b>UPO</b>	[Central Puget Sound] Urban Planning Office
<b>FTA</b>	Federal Transit Administration	<b>USC</b>	United States Code
<b>GIS</b>	Geographic Information System	<b>VE</b>	Value engineering
<b>GLO</b>	General Land Office	<b>VECP</b>	Value Engineering Change Proposal
<b>GMA</b>	Growth Management Act	<b>VIC</b>	Visitor Information Center
<b>HCP</b>	Highway Construction Program	<b>VPH</b>	Vehicles per hour
<b>HMA</b>	Hot mix asphalt	<b>WAC</b>	Washington Administrative Code
<b>HOT</b>	High-occupancy toll	<b>WIM</b>	Weigh in motion
<b>HOV</b>	High-occupancy vehicle	<b>WSDOT</b>	Washington State Department of Transportation
<b>HQ</b>	WSDOT's Headquarters in Olympia	<b>WSPMS</b>	Washington State Pavement Management System
<b>HSP</b>	Highway System Program (also SHSP)	<b>WTP</b>	Washington Transportation Plan

## ADA / Pedestrian Terms

**Note:** This grouping of terms is used primarily in Chapters [1510](#) and [1515](#).

ADA / Pedestrian Terms	
<b>accessible</b>	Usable by persons with disabilities (ADA compliant).
<b>accessible pedestrian signal (APS)</b>	A device that communicates information about the “WALK” phase in audible and vibrotactile (vibrating surface that communicates information through touch, located on the accessible pedestrian signal button) formats.
<b>accessible route</b>	See <a href="#">pedestrian access route</a> .
<b>ADA</b>	An abbreviation for the Americans with Disabilities Act of 1990. The ADA is a civil rights law that identifies and prohibits discrimination based on disability. Title II of the ADA requires public entities to design new pedestrian facilities or alter existing pedestrian facilities to be accessible to and usable by people with disabilities.
<b>alternate pedestrian access route</b>	A temporary accessible route to be used when the existing pedestrian access route is blocked by construction, alteration, maintenance, or other temporary condition(s).
<b>alteration</b>	<p>A change to a facility in the public right of way that affects or could affect access, circulation, or use.</p> <p>Alterations include, but are not limited to: renovation; rehabilitation; reconstruction; historic restoration; resurfacing of circulation paths or vehicular ways; or changes or rearrangement of structural parts or elements of a facility.</p> <p>Alterations <i>do not</i> include: Spot pavement repair; liquid-asphalt sealing, chip seal (bituminous surface treatment), or crack sealing; or lane restriping that does not alter the usability of the shoulder.</p>
<b>buffer</b>	A space measured from the back of the curb to the edge of the sidewalk that could be treated with plantings or alternate pavement, or be used for needs such as drainage treatment or utility placement.
<b>clear width</b>	The unobstructed width within a pedestrian circulation path. The clear width within a pedestrian circulation path must meet the accessibility criteria for a pedestrian access route.
<b>construction impact zone</b>	The area in which an alteration to an existing facility takes place (also known as the project footprint). If a crosswalk (marked or unmarked) will be reconstructed, paved (overlay or inlay), or otherwise altered as part of a project, then the curb ramps that serve that crosswalk are within the construction impact zone.
<b>counter slope</b>	The slope of the gutter or roadway at the foot of a curb ramp or landing where it connects to the roadway, measured along the axis of the running slope extended.
<b>cross slope</b>	The slope measured perpendicular to the direction of travel.
<b>crosswalk</b>	A marked or unmarked pedestrian crossing, typically at an intersection, that connects the pedestrian access routes on opposite sides of a roadway. A crosswalk must meet accessibility criteria.

<b>ADA / Pedestrian Terms</b>	
	<p>A crosswalk is also defined as:</p> <ul style="list-style-type: none"> <li>• "...the portion of the roadway between the intersection area and a prolongation or connection of the farthest sidewalk line or in the event there are no sidewalks then between the intersection area and a line ten feet therefrom, except as modified by a marked crosswalk" (<a href="#">RCW 46.04.160</a>).</li> <li>• "(a) That part of a roadway at an intersection included within the connections of the lateral lines of the sidewalks on opposite sides of the highway measured from the curbs or in the absence of curbs, from the edges of the traversable roadway, and in the absence of a sidewalk on one side of the roadway, the part of the roadway included within the extension of the lateral lines of the sidewalk at right angles to the center line; (b) any portion of a roadway at an intersection or elsewhere distinctly indicated as a pedestrian crossing by lines on the surface, which might be supplemented by contrasting pavement texture, style, or color" (<a href="#">MUTCD, 2003</a>; <i>Guide for the Planning, Design, and Operation of Pedestrian Facilities</i>, AASHTO, 2004).</li> </ul>
<b>curb extension</b>	A curb and sidewalk bulge or extension out into the parking lane used to decrease the length of a pedestrian crossing and increase visibility for the pedestrian and driver.
<b>curb ramp</b>	<p>A combined ramp and landing to accomplish a change in level at a curb. This element provides street and sidewalk access to pedestrians with mobility impairments.</p> <ul style="list-style-type: none"> <li>• <b>parallel curb ramp</b> A curb ramp design where the sidewalk slopes down to a landing at road level with the running slope of the ramp in line with the direction of sidewalk travel</li> <li>• <b>perpendicular curb ramp</b> A curb ramp design where the ramp path is perpendicular to the curb and meets the gutter grade break at a right angle.</li> </ul>
<b>detectable warning surface</b>	A tactile surface feature of truncated dome material built into or applied to the walking surface to alert persons with visual impairments of vehicular ways. Federal yellow is the color used on WSDOT projects to achieve visual contrast. Colors other than federal yellow that meet the light-on-dark/dark-on-light requirement may be used on projects where cities have jurisdiction. (Detectable warning surfaces are detailed in the <a href="#">Standard Plans</a> .)
<b>flangeway gap</b>	The gap for the train wheel at a railroad crossing. The space between the inner edge of a rail and the pedestrian crossing surface.
<b>grade break</b>	The intersection of two adjacent surface planes of different grade.
<b>landing</b>	A level paved area, within or at the top and bottom of a stair or ramp, designed to provide turning and maneuvering space for wheelchair users and as a resting place for pedestrians.
<b>maximum extent feasible (MEF)</b>	<p>From the U.S. Department of Justice, <a href="#">28 CFR Part 36.402</a>, Alterations. The phrase "to the maximum extent feasible" applies to "the occasional case where the nature of an existing facility makes it virtually impossible to comply fully with applicable accessibility standards through a planned alteration."</p> <p>This phrase also refers to a stand-alone piece of design documentation that WSDOT uses to record its reasons for not being able to achieve full ADA compliance in alteration projects (called a Maximum Extent Feasible document).</p>
<b>midblock pedestrian crossing</b>	A marked pedestrian crossing located between intersections.



ADA / Pedestrian Terms	
<b>passenger loading zone</b>	An area provided for pedestrians to board/disembark a vehicle.
<b>pedestrian</b>	Any person afoot or using a wheelchair (manual or motorized) or means of conveyance (other than a bicycle) propelled by human power, such as skates or a skateboard.
<b>pedestrian access route (PAR)</b> (synonymous with <a href="#">accessible route</a> )	A continuous, unobstructed walkway within a pedestrian circulation path that provides accessibility. Pedestrian access routes consist of one or more of the following pedestrian facilities: walkways/sidewalks, curb ramps (excluding flares), landings, crosswalks, pedestrian overpasses/underpasses, access ramps, elevators, and platform lifts.  Note: Not all transportation facilities need to accommodate pedestrians. However, those that do accommodate pedestrians need to have an accessible route.
<b>pedestrian circulation path</b>	A prepared exterior or interior way of passage provided for pedestrian travel. Includes independent walkways, shared-use paths, sidewalks, and other types of pedestrian facilities. All pedestrian circulation paths are required to contain a continuous pedestrian access route that connects to all adjacent pedestrian facilities, elements, and spaces that are required to be accessible.
<b>pedestrian facilities</b>	Walkways such as sidewalks, walking and hiking trails, shared-use paths, pedestrian grade separations, crosswalks, and other improvements provided for the benefit of pedestrian travel. Pedestrian facilities are intended to be accessible routes.
<b>pedestrian overpass or underpass</b>	A grade-separated pedestrian facility, typically a bridge or tunnel structure over or under a major highway or railroad that allows pedestrians to cross.
<b>pedestrian refuge island</b>	An island in the roadway that physically separates the directional flow of traffic, provides pedestrians with a place of refuge, and reduces the crossing distance.  Note: Islands with cut-through paths are more accessible to persons with disabilities than are raised islands with curb ramps.
<b>pedestrian signal</b>	An adaptation of a conventional traffic signal installed at established pedestrian crossings. It is used to provide a protected phase for pedestrians by terminating the conflicting vehicular movements to allow for pedestrian crossings.
<b>person with disability</b>	An individual who has an impairment, including a mobility, sensory, or cognitive impairment, that results in a functional limitation in access to and use of a building or facility.
<b>raised median</b>	A raised island in the center of a road used to restrict vehicle left turns and side street access. Note: Islands with cut-through paths are more accessible to persons with disabilities than are raised islands with curb ramps.
<b>ramp</b>	A walking surface with a running slope steeper than 20H:1V (5%).
<b>running slope</b>	A slope measured in the direction of travel, normally expressed as a percent.
<b>sidewalk</b>	A walkway along a highway, road, or street intended for use by pedestrians.
<b>site</b>	A parcel of land bounded by a property line or a designated portion of a public right of way.
<b>street furniture</b>	Sidewalk equipment or furnishings, including garbage cans, benches, parking meters, and telephone booths.

<b>ADA / Pedestrian Terms</b>	
<b>traffic calming</b>	Design techniques that have been shown to reduce traffic speeds and unsafe maneuvers. These techniques can be stand-alone or used in combination, and they include lane narrowing, curb extensions, surface variations, and visual clues in the vertical plane.
<b>transitional segments</b>	Segments of a pedestrian circulation path that blend between existing undisturbed pedestrian facilities and newly altered pedestrian facilities. Use of transitional segments may permit the work of the alteration to more nearly meet the new construction standards. At a later time, when other segments of the pedestrian circulation path are altered, the noncomplying transitional segments can be removed and replaced with pedestrian facilities that meet the accessibility criteria.
<b>universal access</b>	Access for all persons regardless of ability or stature.
<b>walk interval</b>	That phase of a traffic signal cycle during which the pedestrian is to begin crossing, typically indicated by a WALK message or the walking person symbol and its audible equivalent.
<b>walkway</b>	The continuous portion of the pedestrian access route that is connected to street crossings by curb ramps.

## Main Glossary of Terms

---

A B C D E F G H I J K L M N O P Q R S T U V W Y

### A

**access** A means of entering or leaving a public road, street, or highway with respect to abutting property or another public road, street, or highway.

**access break** Any point from inside or outside the state limited access right of way limited access hachures that crosses over, under, or physically through the plane of the limited access, is an access break or “break in access,” including, but not limited to, locked gates and temporary construction access breaks.

**access connection** An access point, other than a public road/street, that permits access to or from a managed access highway on the state highway system.

**access connection permit** A written authorization issued by the permitting authority for a specifically designed access connection to a managed access highway at a specific location; for a specific type and intensity of property use; and for a specific volume of traffic for the access connection based on the final stage of the development of the applicant’s property. The actual form used for this authorization is determined by the permitting authority.

**access control** The limiting and regulating of public and private access to Washington State’s highways, as required by state law.

**Access Control Tracking System Limited Access and Managed Access Master Plan** A database list, related to highway route numbers and mileposts, that identifies either the level of limited access or the class of managed access: [www.wsdot.wa.gov/design/accessandhearings](http://www.wsdot.wa.gov/design/accessandhearings)

**access deviation** A deviation (see [Chapter 300](#)) that authorizes deferring or staging acquisition of limited access control, falling short of a 300-foot requirement, or allowing an existing access point to stay within 130 feet of an intersection on a limited access highway. Approval by the Director & State Design Engineer, Development Division, is required (see [Chapter 530](#)).

**access hearing plan** A limited access plan prepared for presentation at an access hearing.

**access point** Any point that allows private or public entrance to or exit from the traveled way of a state highway, including “locked gate” access and maintenance access points.

**access point revision** A new access point or a revision of an existing interchange/ intersection configuration. Locked gates and temporary construction breaks are also access point revisions.

**access point spacing** On a managed access highway, the distance between two adjacent access points on one side of the highway, measured along the edge of the traveled way from one access point to the next (see also [corner clearance](#)).

**access report plan** A limited access plan prepared for presentation to local governmental officials at preliminary meetings before preparation of the access hearing plan.

**access rights** Property rights that allow an abutting property owner to enter and leave the public roadway system.

**affidavit of publication** A notarized written declaration stating that a *notice of hearing* (or *notice of opportunity for a hearing*) was published in the legally prescribed manner.

**affidavit of service by mailing** A notarized written declaration stating that the limited access hearing packet was mailed at least 15 days prior to the hearing and entered into the record at the hearing.

**alternatives** Possible solutions to accomplish a defined purpose and need. These include local and state transportation system mode and design options, locations, and travel demand management and transportation system management-type improvements such as ramp metering, mass transit, and high-occupancy vehicle (HOV) facilities.

**ancillary services** Those secondary services, also considered amenities, provided at safety rest areas that include, but are not limited to, vending machines, picnic areas, interpretive signing, telephones, recreational vehicle (RV) sanitary disposal facilities, trails, scenic viewpoints, commercial and public information displays, and visitor information centers.

**annual average daily traffic (AADT)** The total volume of traffic passing a point or segment of a highway facility in both directions for one year divided by the number of days in the year.

**annual daily traffic (ADT)** The volume of traffic passing a point or segment of a highway, in both directions, during a period of time, divided by the number of days in the period, and factored to represent an estimate of traffic volume for an average day of the year.

**application for an access connection** An application provided by the permitting authority to be completed by the applicant for access to a managed access highway.

**approach** An access point, other than a public road/street, that allows access to or from a limited access highway on the state highway system.

**approach and access connection** These terms are listed under the specific access section to which they apply. The first section below is for limited access highways and uses the term *approach*. The second section below is for managed access highways and uses the term *access connection*. Approaches and access connections include any ability to leave or enter a highway right of way other than at an intersection with another road or street.

(a) **limited access highways: approach** An access point, other than a public road/street, that allows access to or from a limited access highway on the state highway system. There are five types of approaches to limited access highways that are allowed:

- **Type A** An off and on approach in a legal manner, not to exceed 30 feet in width, for the sole purpose of serving a single-family residence. It may be reserved by the abutting owner for specified use at a point satisfactory to the state at or between designated highway stations. This approach type is allowed on partial and modified control limited access highways.
- **Type B** An off and on approach in a legal manner, not to exceed 50 feet in width, for use necessary to the normal operation of a farm, but not for retail marketing. It may be reserved by the abutting owner for specified use at a point satisfactory to the state at or between designated highway stations. This approach type is allowed on partial and modified control limited access highways. This approach type may be used for wind farms when use of the approach is limited to those vehicles necessary to construct and maintain the farm for use in harvesting wind energy.

- **Type C** An off and on approach in a legal manner, for a special purpose and width to be agreed upon. It may be specified at a point satisfactory to the state at or between designated highway stations. This approach type is allowed on partial and modified control limited access highways and on full control limited access highways where no other reasonable means of access exists, as solely determined by the department.
  - **Type D** An off and on approach in a legal manner, not to exceed 50 feet in width, for use necessary to the normal operation of a commercial establishment. It may be specified at a point satisfactory to the state at or between designated highway stations. This approach type is allowed only on modified control limited access highways.
  - **Type E** This type is no longer allowed to be constructed because of the requirements that there be only one access point per parcel on a limited access state highway.
  - **Type F** An off and on approach in a legal manner, not to exceed 30 feet in width, for the sole purpose of serving a wireless communication site. It may be specified at a point satisfactory to the state at or between designated highway stations. This approach type is allowed only on partial control limited access highways. (See [WAC 468-58-080\(vi\)](#) for further restrictions.)
- (b) **managed access highways: access connection** An access point, other than a public road/street, that permits access to or from a managed access highway on the state highway system. There are five types of access connection permits:
- **conforming access connection** A connection to a managed access highway that meets current WAC and WSDOT location, spacing, and design criteria.
  - **grandfathered access connection** Any connection to the state highway system that was in existence and in active use on July 1, 1990, and has not had a significant change in use.
  - **joint-use access connection** A single connection to a managed access highway that serves two or more properties.
  - **nonconforming access connection** A connection to a managed access highway that does not meet current WSDOT location, spacing, or design criteria, pending availability of a future conforming access connection.
  - **variance access connection** A connection to a managed access highway at a location not normally allowed by current WSDOT criteria.
- (c) **managed access connection category** There are four access connection permit categories for managed access connections to state highways: Category I, Category II, Category III, and Category IV (see [Chapter 540](#)).

**approach design speed** The design speed of the roadway leading into the roundabout.

**approach lanes** The lane or set of lanes for traffic approaching the roundabout (see [Chapter 1320](#)).

**area of influence** The area that will be directly impacted by the proposed action: freeway main line, ramps, crossroads, immediate off-system intersections, and state and local roadway systems.

**articulated bus** A two-section bus that is permanently connected at a joint.

**auxiliary aids and services** (1) Qualified interpreters, notetakers, transcription services, written materials, telephone handset amplifiers, assistive listening devices, assistive listening systems, telephones compatible with hearing aids, open and closed captioning, telecommunications devices for deaf persons (TDDs), videotext displays, or other effective methods for making aurally delivered materials available to individuals with hearing limitations; (2) Qualified readers, taped texts, audio recordings, Brailled materials, large print materials, or other effective methods for making visually delivered materials available to individuals with visual impairments; (3) Acquisition or modification of equipment or devices; (4) Other similar services and actions; and (5) Providing and disseminating information, written materials, and notices in languages other than English, where appropriate.

**auxiliary lane** The portion of the roadway adjoining the through lanes for parking, speed change, turning, storage for turning, weaving, truck climbing, and other purposes supplementary to through-traffic movement.

**average daily traffic (ADT)** The total volume during a given time period (in whole days): greater than one day and less than one year, divided by the number of days in that time period.

**average light level** The average of all light intensities within the design area.

**average weekday vehicle trip ends (AWDVTE)** The estimated total of all trips entering plus all trips leaving a road approach on a weekday for the final stage of development of the property served by the road approach.

## **B**

**backslope** A sideslope that goes up as the distance increases from the roadway (cut slopes).

**barrier terminal** A crash-tested end treatment for longitudinal barriers that is designed to reduce the potential for spearing, vaulting, rolling, or excessive deceleration of impacting vehicles from either direction of travel. Barrier terminals include applicable anchorage.

**baseline** The existing transportation system configuration and traffic volumes for a specific year against which to compare possible alternative solutions.

**basic number of lanes** The minimum number of general purpose lanes designated and maintained over a significant length of highway.

**benefit cost (b/c) ratio** A method for prioritizing highway improvement projects. The b/c ratio is determined by dividing measurable benefits (based on improvement in performance) by measurable costs for a specific time period.

**bicycle** Any device propelled solely by human power upon which a person or persons may ride, having two tandem wheels, either of which is 16 inches or more in diameter, or three wheels, any one of which is more than 20 inches in diameter.

**bicycle route** A system of facilities that is used or has a high potential for use by bicyclists or that is designated as such by the jurisdiction having the authority. A series of bicycle facilities may be combined to establish a continuous route and may consist of any or all types of bicycle facilities.

**bike lane** A portion of a highway or street identified by signs and pavement markings as reserved for bicycle use.

**break** See [access break](#).

**bridge project** A bridge project shall include any project where the primary purpose is to construct, reconstruct, rehabilitate, resurface, or restore a bridge ([23 CFR 636.103](#)). Notes:

- A VE analysis must be conducted on all federally funded bridge projects with an estimated total cost of \$20 million or more.
- WSDOT's policy is also to conduct a VE analysis for any bridge project with an estimated total cost of \$20 million or more.

**buffer-separated HOV lane** An HOV lane that is separated from the adjacent same direction general-purpose freeway lanes by a designated buffer.

**bus** A rubber-tired motor vehicle used for transportation, designed to carry more than ten passengers.

**business access transit (BAT) lanes** A transit lane that allows use by other vehicles to access abutting businesses.

**bus pullout** A bus stop with parking area designed to allow transit vehicles to stop wholly off the roadway.

**bus rapid transit (BRT)** An express rubber tired transit system operating predominantly in roadway managed lanes. It is generally characterized by separate roadway or buffer-separated HOV lanes, HOV direct access ramps, and a high-occupancy designation (3+ or higher).

**bus shelter** A facility that provides seating and protection from the weather for passengers waiting for a bus.

**bus stop** A place designated for transit vehicles to stop and load or unload passengers.

## C

**capacity** The maximum sustainable flow rate at which vehicles or persons can reasonably be expected to traverse a point or uniform segment of a lane or roadway during a specified time period under given roadway, geometric, traffic, environmental, and control conditions. Capacity is usually expressed as vehicles per hour (vph), passenger cars per hour (pcph), or persons per hour (pph).

**Capital Improvement and Preservation Program (CIPP)** WSDOT's program of projects developed each biennium that delivers capital investments in highway, marine, and rail facilities that have been funded in part or in whole by the state Legislature. The CIPP is submitted to the Governor and, ultimately, by the Governor to the Legislature.

**Capital Program Management System (CPMS)** A computer database used to develop and manage the highway and marine construction programs. The CPMS allows users to establish and maintain project data and is used to manage and deliver statewide construction programs.

**capture trips** Trips that do not enter or leave the traveled ways of a project's boundary within a mixed-use development.

**carpool/vanpool** A group of people who share the use and cost of a car or van for transportation on a regular basis.

**Categorical Exclusion (CE) (NEPA) or Categorical Exemption (CE) (SEPA)** Actions that do not individually or cumulatively have a significant effect on the environment.

**central island** The area of the roundabout, including the truck apron, surrounded by the circulating roadway.

**central island diameter** The diameter of the central island, including the truck apron (see [Chapter 1320](#)).

**circulating lane** A lane used by vehicles circulating in the roundabout.

**circulating roadway** The traveled lane(s) adjacent to the central island and outside the truck apron, including the entire 360° circumference of the circle.

**circulating roadway width** The total width of the circulating lane(s) measured from inscribed circle to the central island (see [Chapter 1320](#)).

**clear run-out area** The area beyond the toe of a nonrecoverable slope available for use by an errant vehicle.

**clear zone** The total roadside border area, available for use by errant vehicles, starting at the edge of the traveled way and oriented from the outside or inside shoulder (in median applications) as applicable. This area may consist of a shoulder, a recoverable slope, a nonrecoverable slope, and/or a clear run-out area. The clear zone cannot contain a critical fill slope, fixed objects, or water deeper than 2 feet.

**climbing lane** An auxiliary lane used for the diversion of slow traffic from the through lane.

**coefficient of retroreflection ( $R_s$ )** A measure of retroreflection.

**collector-distributor road (C-D road)** A parallel roadway designed to remove weaving from the main line and reduce the number of main line entrances and exits.

**collector system** Routes that primarily serve the more important intercounty, intracounty, and intraurban travel corridors; collect traffic from the system of local access roads and convey it to the arterial system; and on which, regardless of traffic volume, the predominant travel distances are shorter than on arterial routes ([RCW 47.05.021](#)).

**collision rate** Collisions per one million vehicle miles traveled and fatal rates per one hundred million vehicle miles.

**Commercial Vehicle Information Systems and Networks (CVISN)** A network that links intelligent transportation systems (ITS) to share information on commercial vehicles. When in operation at a weigh site, it can enable commercial vehicles to clear the facility without stopping.

**complex ramp alignment and grade** The exit advisory speed is 35 mph or lower than the posted main line speed, or there is a 6% or greater change in grade from existing main line grade to the ramp grade.

**conflict** An event involving two or more road users in which the action of one user causes the other user to make an evasive maneuver to avoid a collision.

**conflict point** A point where traffic paths cross, merge, or diverge.

**connection** See [approach and access connection](#).

**consider** To think carefully about, especially in order to make a decision. No backup documentation is required.



**context sensitive solutions (CSS)** A collaborative, interdisciplinary approach that involves all stakeholders to develop a transportation facility that fits its physical setting and preserves scenic, aesthetic, historic, and environmental resources while maintaining safety and mobility. CSS is an approach that considers the total context within which a transportation improvement project will exist.

**contiguous parcels** Two or more pieces of real property, under the same ownership, with one or more boundaries that touch and have similarity of use.

**continuous load** The electrical load on a circuit that lasts for a duration of three or more hours on any day.

**controlled releasing terminal (CRT) post** A standard-length guardrail post that has two holes drilled through it so it might break away when struck.

**conventional traffic signal** A permanent or temporary installation providing alternating right of way assignments for conflicting traffic movements. At least two identical displays are required for the predominant movement on each approach.

**corner clearance** On a managed access highway, the distance from an intersection of a public road or street to the nearest access connection along the same side of the highway. The minimum corner clearance distance (see [Chapter 540](#)) is measured from the closest edge of the intersecting road or street to the closest edge of the traveled way of the access connection, measured along one side of the traveled way (through lanes) (see also [access point spacing](#)).

**corridor analysis** Documentation that justifies a change in design level and/or decisions to include, exclude, or modify design elements. A corridor analysis addresses needs and design solutions within a substantial segment of roadway. A corridor analysis is useful beyond a specific project contained within it, and it is an appropriate document to address design speed.

**court reporter** A person with a license to write and issue official accounts of judicial or legislative proceedings.

**crash-accepted device** A feature that has been proven acceptable for use under specified conditions, either through crash testing or in-service performance.

**critical fill slope** A slope on which a vehicle is likely to overturn. Slopes steeper than 3H:1V are considered critical fill slopes.

**crossroad** The minor roadway at an intersection. At a stop-controlled intersection, the crossroad has the stop.

**curb section** A roadway cross section with curb and sidewalk.

## D

**decision sight distance** The distance needed for a driver to detect an unexpected or difficult-to-perceive condition, recognize the condition, select an appropriate maneuver, and complete the maneuver based on design conditions and design speed.

**deflection** (in respect to roundabouts) The change in the path of a vehicle imposed by the geometric features of a roundabout resulting in a slowing of vehicles.

**delineation** Any method of defining the roadway operating area for the driver.

**departure lanes** The lane or set of lanes for traffic leaving the roundabout (see [Chapter 1320](#)).

**Design Approval** Documented approval of the design criteria, which becomes part of the Design Documentation Package. This approval is an endorsement of the design criteria by the designated representative of the approving organization as shown in [Chapter 300](#).

**design-bid-build** The project delivery method where design and construction are sequential steps in the project development process ([23 CFR 636.103](#)).

**design-build contract** An agreement that provides for design and construction of improvements by a consultant/contractor team. The term encompasses design-build-maintain, design-build-operate, design-build-finance, and other contracts that include services in addition to design and construction. Franchise and concession agreements are included in the term if they provide for the franchisee or concessionaire to develop the project that is the subject of the agreement ([23 CFR 636.103](#)).

**design-builder** The firm, partnership, joint venture, or organization that contracts with WSDOT to perform the work.

**Design Clear Zone** The minimum clear zone target value used in highway design.

**Design Documentation Package (DDP)** See [Project File](#).

**designer** This term applies to WSDOT design personnel. Wherever “designer” appears in this manual, design-build personnel shall deem it to mean: Engineer of Record, Design Quality Assurance Manager, design-builder, or any other term used in the design-build contract to indicate design-build personnel responsible for the design elements of a design-build project, depending on the context of information being conveyed.

**design exception (DE)** A method to document a geometric feature that has been preauthorized to exclude improvement of an existing design element for various types of projects, as designated in the design matrices (see [Chapter 1100](#)). A DE designation indicates that the design element is normally outside the scope of the project type (see [Chapter 300](#)). Some design exceptions require justification.

**design hourly volume (DHV)** Computed by taking the annual average daily traffic times the K-factor. It can only be accurately determined in locations where there is a permanent traffic recording device active 365 days of the year. It correlates to the peak hour (see [peak hour](#)), but it is not equivalent. In some circumstances, it is necessary to use the peak hour data instead of DHV because peak hour can be collected using portable traffic recorders.

**design speed** The speed used to determine the various geometric design features of the roadway.

**design variance** A recorded decision to differ from the design level specified in the *Design Manual*, such as an evaluate upgrade (EU) not upgraded, a DE, or a deviation. EUs leading to an upgrade are documented but are not considered to be variances. A project or corridor analysis may also constitute a design variance if that analysis leads to a decision to use a design level or design classification that differs from what the *Design Manual* specifies for the project type.

**Design Variance Inventory (DVI)** A list of design elements that will not be improved in accordance with the *Design Manual* criteria designated for the project. Only approved variances should be included on this list.

**Design Variance Inventory System (DVIS)** A database application developed to generate the DVI form. The DVIS also provides query functions, giving designers an opportunity to search for previously granted variances. The DVIS was started in the early 2000s and does not identify prior variances. The *Design Manual* is constantly being refined and guidelines change over time. What may have been a design variance previously may not be a deviation today. Previously approved design variances do not carry forward and must be revisited as described in [Chapter 300](#). The DVIS database is intended for internal WSDOT use only, and WSDOT staff access it from the left margin of this website:

🔗 <http://wwwi.wsdot.wa.gov/design/>

**design vehicle** A vehicle used to establish the intersection geometry.

**design year** 20 years from the beginning of construction.

**desirable** Design criteria that are recommended for inclusion in the design.

**Determination of Nonsignificance (DNS) (SEPA)** The written decision by the Regional Administrator that a proposal will not have a significant impact and no EIS is required.

**Determination of Significance (DS) (SEPA)** A written decision by the Regional Administrator that a proposal could have a significant adverse impact and an EIS is required.

**deviation** A documented decision granting approval at project-specific locations to differ from the design level specified in the *Design Manual* (see Chapters [1100](#) and [300](#)).

**directional design hour volume (DDHV)** The traffic volume for the design hour in the peak direction of flow, in vehicles per hour. For example, if during the design hour, 60% of the vehicles traveled eastbound and 40% traveled westbound, then the DDHV for the eastbound direction would be the DHV x 0.60.

**divided multilane** A roadway with two or more through lanes in each direction and a median that physically or legally prohibits left turns, except at designated locations.

**document** (verb) The act of including a short note to the Design Documentation Package that explains a design decision.

**double-lane roundabout** A roundabout with a two-lane circulating roadway and one or more entry or exit legs with two lanes.

**driveway** A vehicular access point that provides access to or from a public roadway.

**drop and ride** An area of a park & ride lot or other multimodal facility where patrons are dropped off or picked up by private auto or taxi.

**durability** A measure of a traffic line's resistance to the wear and deterioration associated with abrasion and chipping.

## E

**easement** A documented right, as a right of way, to use the property of another for designated purposes.

**element** An architectural or mechanical component or design feature of a space, site, or public right of way.

**emergency escape ramp** A roadway leaving the main roadway designed for the purpose of slowing and stopping out-of-control vehicles away from the main traffic stream.

**emergency vehicle signal** A special adaptation of a conventional traffic signal installed to allow for the safe movement of authorized emergency vehicles. Usually, this type of signal is installed on the highway at the entrance into a fire station or other emergency facility. The signal ensures protected entrance onto the highway for the emergency vehicle. When not providing for this movement, the signal either operates continuously (consistent with the requirements for a conventional traffic signal) or displays continuous green, which is allowed at non-intersection locations only. At least two identical displays are required per approach.

**enforcement observation point** A place where a law enforcement officer may park and observe traffic.

**entry angle** The angle between the entry roadway and the circulating roadway measured at the yield point (see [Chapter 1320](#)).

**entry curve** The curve of the left edge of the roadway that leads into the circulating roadway (see [Chapter 1320](#)).

**entry width** The width of an entrance leg at the inscribed circle measured perpendicular to travel (see [Chapter 1320](#)).

**Environmental Assessment (EA)** (NEPA) A document prepared for federally funded, permitted, or licensed projects that are not categorical exclusions (CE), but do not appear to be of sufficient magnitude to require an EIS. The EA provides enough analysis to determine whether an EIS or a FONSI should be prepared.

**Environmental Classification Summary (ECS)** A form used to evaluate and classify projects for the construction program. The ECS supports a decision of a documented CE.

**Environmental Impact Statement (EIS)** A detailed written statement of a proposed course of action, project alternatives, and possible impacts of the proposal.

**Environmental Review Summary (ERS)** (see [Project Summary](#)) Part of the Project Summary document, the ERS identifies environmental permits and approvals. It is prepared in the region and is required for Design Approval.

**evaluate upgrade (EU)** A decision-making process to determine whether or not to upgrade an existing design element as designated in the design matrices. Documentation is required (see [Chapter 300](#)).

**exit curve** The curve of the left edge of the roadway that leads out of the circulating roadway (see [Chapter 1320](#)).

**exit width** The width of an exit leg at the inscribed circle (see [Chapter 1320](#)).

**expressway** A divided highway that has a minimum of two lanes in each direction for the exclusive use of traffic and that may or may not have grade separations at intersections.

**extrude** A procedure for applying marking material to a surface by forcing the material through a die to give it a certain shape.

---

**F**

**facility** All or any portion of buildings, structures, improvements, elements, and pedestrian or vehicular routes located in a public right of way.

**feature** A component of a pedestrian access route, such as a curb ramp, driveway, crosswalk, or sidewalk.

**Federal Highway Administration (FHWA)** The division of the U.S. Department of Transportation with jurisdiction over the use of federal transportation funds for state highway and local road and street improvements.

**Federal Transit Administration (FTA)** The division of the U.S. Department of Transportation with jurisdiction over the use of federal funds for financial assistance to develop new transit systems and improve, maintain, and operate existing systems.

**feeder service** Bus service that provides connections with other bus or rail services.

**final design** Any design activities following preliminary design; expressly includes the preparation of final construction plans and detailed specifications for the performance of construction work ([23 CFR 636.103](#)). Final design is also defined by the fact that it occurs *after* NEPA/SEPA approval has been obtained.

**Finding of No Significant Impact (FONSI) (NEPA)** A federal document indicating that a proposal will not significantly affect the environment and an EIS is not required.

**findings and order** A document containing the findings and conclusions of a limited access hearing approved by the Assistant Secretary, Engineering & Regional Operations (see [Chapter 210](#)).

**findings and order plan** A limited access plan, prepared after a limited access hearing, which is based on the hearing record.

**fixed feature (object to be mitigated)** A fixed object, a side slope, or water that, when struck, can result in impact forces on a vehicle's occupants that may result in injury or place the occupants in a situation that has a high likelihood of injury. A fixed feature can be either constructed or natural.

**flare** The widening of the approach to the roundabout to increase capacity and facilitate natural vehicle paths.

**flasher warning assembly** Flashing beacons that are used only to supplement an appropriate warning or regulatory sign or marker. The displays consist of two alternating flashing yellow indications.

**flyer stop** A transit stop inside the limited access boundaries.

**footcandle (fc)** The illumination of a surface one square foot in area on which a flux of one lumen is uniformly distributed. One footcandle equals one lumen per square foot.

**foreslope** A sideslope that goes down as the distance increases from the roadway (fill slopes and ditch inslopes).

**freeway** A divided highway that has a minimum of two lanes in each direction for the exclusive use of traffic and with full control of access.

**frontage road** An auxiliary road that is a local road or street located beside a highway for service to abutting property and adjacent areas and for control of access.

**functional classification** The grouping of streets and highways according to the character of the service they are intended to provide.

## G

**geocomposites** Prefabricated edge drains, wall drains, and sheet drains that typically consist of a cusped or dimpled polyethylene drainage core wrapped in a geotextile. The geotextile wrap keeps the core clean so that water can freely flow through the drainage core, which acts as a conduit. Prefabricated edge drains are used in place of shallow geotextile-wrapped trench drains at the edges of the roadway to provide subgrade and base drainage. Wall drains and sheet drains are typically placed between the back of the wall and the soil to drain the soil retained by the wall.

**Geographic Information System (GIS)** A computerized geographic information system used to store, analyze, and map data. Data may be used with GIS if the data includes the Accumulated Route Mile (ARM) or State Route Milepost (SRMP) programs. Global Positioning System (GPS) technology provides a means of collecting data and is an alternative to ARM and SRMP. WSDOT's primary desktop tool to view and analyze GIS data is ArcGIS software. GIS is used to gather and analyze data to support the purpose and need as described in the Project Summary (<http://wwwi.wsdot.wa.gov/gis/supportteam/default.asp>).

**geogrids** A polymer grid mat constructed either of coated yarns or a punched and stretched polymer sheet. Geogrids usually have high strength and stiffness and are used primarily for soil reinforcement.

**geomembranes** Impervious polymer sheets that are typically used to line ponds or landfills. In some cases, geomembranes are placed over moisture-sensitive swelling clays to control moisture.

**geonets** Similar to geogrids, but typically lighter weight and weaker, with smaller mesh openings. Geonets are used in light reinforcement applications or are combined with drainage geotextiles to form a drainage structure.

**geosynthetic erosion control** The minimizing of surficial soil particle movement due to the flow of water over the surface of bare soil or due to the disturbance of soil caused by construction activities under or near bodies of water. This is the primary function of geotextiles used as silt fences or placed beneath riprap or other stones on soil slopes. Silt fences keep eroded soil particles on the construction site, whereas geotextiles placed beneath riprap or other stones on soil slopes prevent erosion from taking place at all. In general, the permanent erosion control methods described in [Chapter 630](#) are only used where more natural means (like the use of biodegradable vegetation mats to establish vegetation to prevent erosion) are not feasible. These functions control some of the geosynthetic properties, such as apparent opening size (AOS) and permittivity, and in some cases load-strain characteristics. The application will also affect the geosynthetic installation conditions. These installation conditions influence the remaining geosynthetic properties needed, based on the *survivability* level required.

**geosynthetic filtration** The passage of water through the geosynthetic relatively unimpeded (permeability or permittivity) without allowing passage of soil through the geosynthetic (retention). This is the primary function of geotextiles in underground drainage applications.

**geosynthetic survivability** The ability of the geosynthetic to resist installation conditions without significant damage, such that the geosynthetic can function as intended. Survivability affects the strength properties of the geosynthetic required.

**geotextiles (nonwoven)** A sheet of continuous or staple fibers entangled randomly into a felt for needle-punched nonwovens and pressed and melted together at the fiber contact points for heat-bonded nonwovens. Nonwoven geotextiles tend to have low-to-medium strength and stiffness with high elongation at failure and relatively good drainage characteristics. The high elongation characteristic gives them superior ability to deform around stones and sticks.

**geotextiles (woven)** Slit polymer tapes, monofilament fibers, fibrillated yarns, or multifilament yarns simply woven into a mat. Woven geotextiles generally have relatively high strength and stiffness and, except for the monofilament wovens, relatively poor drainage characteristics.

**glass beads** Small glass spheres used in highway pavement markings to provide the necessary retroreflectivity.

**gore** The area downstream from the intersection of the shoulders of the main line and exit ramp. Although generally referring to the area between a main line and an exit ramp, the term may also be used to refer to the area between a main line and an entrance ramp.

**gore nose** At an exit ramp, the point at the end of the gore area where the paved shoulders of the main line and the ramp separate (see [Chapter 1360](#)) or the beginning of traffic barrier, not including any impact attenuator. Also, the similar point at an entrance ramp.

## H

**hearing** An assembly to which the public is invited and at which participation is encouraged. Types of hearings include:

- **administrative appeal hearing** A formal process whereby a property owner may appeal WSDOT's implementation of access management legislation. The appeal is heard by an administrative law judge (ALJ), who renders a decision. (See [Chapter 540](#) for administrative appeal hearing procedures.)
- **combined hearing** A hearing held when there are public benefits to be gained by combining environmental, corridor, design, and/or limited access subjects.
- **corridor hearing** A formal or informal hearing that presents the corridor alternatives to the public for review and comment before a commitment is made to any one route or location. This type of hearing is beneficial for existing corridors with multiple Improvement projects programmed over a long duration.
- **design hearing** A formal or informal hearing that presents the design alternatives to the public for review and comment before the selection of a preferred alternative.
- **environmental hearing** A formal or informal hearing documenting that social, economic, and environmental impacts have been considered and that public opinion has been solicited.
- **formal hearing format** A hearing conducted by a moderator using a formal agenda, overseen by a hearing examiner, and recorded by a court reporter, as required by law. Limited access hearings require the use of the formal hearing format (see [Chapter 210](#)).
- **informal hearing format** A hearing where oral comments are recorded by a court reporter, as required by law. An informal hearing often uses the "open house" format (see [Chapter 210](#)). A formal agenda and participation by a hearing examiner are optional.
- **limited access hearing** A formal hearing that gives local public officials, owners of abutting properties, and other interested persons an opportunity to be heard about the limitation of access to the highway system.

**hearing agenda** An outline of the actual public hearing elements, used with formal hearings. (See [Chapter 210](#) for contents.)

**Hearing Coordinator** The Development Services & Access Manager within the HQ Access and Hearings Section: (360) 705-7251.

**hearing examiner** An administrative law judge from the Office of Administrative Hearings, or a WSDOT designee, appointed to moderate a hearing.

**hearing script** A written document of text to be presented orally by department representatives at a hearing.

**hearing summary** Documentation prepared by the region and approved by Headquarters that summarizes environmental, corridor, and design hearings. (See [Chapter 210](#) for content requirements.)

**hearing transcript** A document prepared by the court reporter that transcribes verbatim all oral statements made during the hearing, including public comments. This document becomes part of the official hearing record.

**high-occupancy toll (HOT) lane** A managed lane that combines a high-occupancy vehicle lane and a toll lane.

**high-occupancy vehicle (HOV)** A vehicle that meets the occupancy requirements of the facility as authorized by [WAC 468-510-010](#).

**high pavement type** Portland cement concrete pavement or hot mix asphalt (HMA) pavement on a treated base.

**high-speed roadway** A roadway with a posted speed of 45 mph or higher.

**highway** A general term denoting a street, road, or public way for the purpose of vehicular travel, including the entire area within the right of way.

**Highway Construction Program (HCP)** A comprehensive multiyear program of highway Improvement and Preservation projects selected by the Legislature.

**Highway System Plan (HSP)** A WSDOT planning document that addresses the state highway system element of the Washington Transportation Plan (WTP). The HSP defines the service objectives, action strategies, and costs to maintain, operate, preserve, and improve the state highway system for 20 years. The HSP is the starting point for the state highway element of the CIPP and the state Highway Construction Program. It is periodically updated to reflect completed work and changing transportation needs, policies, and revenues. It compares highway needs to revenues, describes the “constrained” costs of the highway programs, and provides details of conceptual solutions and performance in the improvement program.

**HOV direct access ramp** An on- or off-ramp exclusively for the use of HOVs that provides access between a freeway HOV lane and a street, transit support facility, or another freeway HOV lane without weaving across general-purpose lanes.

**HOV facility** A priority treatment for HOVs.



---

**I**

**impact attenuator system** A device that acts primarily to bring an errant vehicle to a stop at a deceleration rate tolerable to the vehicle's occupants or to redirect the vehicle away from a fixed feature.

**incorporated city or town** A city or town operating under [RCW 35](#) or [35A](#).

**inscribed circle** The outer edge of the circulating roadway.

**inscribed circle diameter (ICD)** The diameter of the inscribed circle (see [Chapter 1320](#)).

**intelligent transportation systems (ITS)** An integrated system of advanced sensor, computer, electronics, and communication technologies and management strategies, used to increase the safety and efficiency of the surface transportation system.

**interchange** A system of interconnecting roadways, in conjunction with one or more grade separations, providing for the exchange of traffic between two or more intersecting highways or roadways.

**Interchange Justification Report (IJR)** The document used to propose a revision to limited access freeways.

**intermediate pavement type** Hot mix asphalt pavement on an untreated base.

**intersection** An at-grade access point connecting a state highway with a road or street duly established as a public road or public street by the local governmental entity.

**intersection angle** The angle between any two intersecting legs at the point the centerlines intersect.

**intersection area** The area of the intersecting roadways bounded by the edge of traveled ways and the area of the adjacent roadways to the farthest point: (a) the end of the corner radii, (b) through any marked crosswalks adjacent to the intersection, (c) to the stop bar, or (d) 10 feet from the edge of shoulder of the intersecting roadway (see [Chapter 1310](#)).

**intersection at grade** The general area where a roadway or ramp terminal is met or crossed at a common grade or elevation by another roadway.

- **four-leg intersection** An intersection formed by two crossing roadways.
- **split tee** A four-leg intersection with the crossroad intersecting the through roadway at two tee intersections offset by at least the width of the roadway.
- **tee (T) intersection** An intersection formed by two roadways where one roadway terminates at the point it meets a through roadway.
- **wye (Y) intersection** An intersection formed by three legs in the general form of a "Y" where the angle between two legs is less than 60°.

**intersection control beacon** (also flashing beacon) A secondary control device, generally suspended over the center of an intersection, that supplements intersection warning signs and stop signs. One display per approach may be used; however, two displays per approach are desirable. Intersection control beacons are installed only at intersections that control two or more directions of travel.

**intersection leg** Any one of the roadways radiating from and forming part of an intersection.

- **entrance leg** The lanes of an intersection leg for traffic entering the intersection.
- **exit leg** The lanes of an intersection leg for traffic leaving the intersection.

**Note:** Whether an intersection leg is an entrance leg or an exit leg depends on which movement is being analyzed. For two-way roadways, each leg is an entrance leg for some movements and an exit leg for other movements.

**intersection sight distance** The length of roadway visible to the driver of a vehicle entering an intersection.

**Interstate System** A network of routes designated by the state and the Federal Highway Administration (FHWA) under terms of the federal-aid acts as being the most important to the development of a national system. The Interstate System is part of the principal arterial system.

**island** A defined area within an intersection, between traffic lanes, for the separation of vehicle movements or for pedestrian refuge.

## J

**justify** Preparing a memo to the DDP identifying the reasons for the decision: a comparison of advantages and disadvantages of all options considered. A more rigorous effort than *document*.

## K

**K-factor** The proportion of AADT occurring in the analysis hour is referred to as the K-factor, expressed as a decimal fraction (commonly called “K,” “K30,” or “K100”). The K30 is the thirtieth (K100 is the one-hundredth) highest peak hour divided by the annual average daily traffic. Normally, the K30 or K100 will be in the range of 0.09 to 0.10 for urban and rural areas. Average design hour factors are available on the web in the Statewide Travel and Collision Data Office’s Annual Peak Hour Report.

## L

**lamp lumens** The total light output from a lamp, measured in lumens.

**lane** A strip of roadway used for a single line of vehicles.

**lane control signal** (reversible lanes) A special overhead signal that permits, prohibits, or warns of impending prohibition of lane use.

**lane width** The lateral design width for a single lane, striped as shown in the [Standard Plans](#) and the [Standard Specifications](#). The width of an existing lane is measured from the edge of traveled way to the center of the lane line or between the centers of adjacent lane lines.

**lateral clearance** The distance from the edge of traveled way to a roadside object.

**lead agency** The public agency that has the principal responsibility for carrying out or approving a project.

**legal road approach** A road approach that complies with the requirements of [Chapter 530](#) for limited access facilities and [Chapter 540](#) for managed access facilities.

**length of need** The length of a traffic barrier used to shield a fixed feature.

**level of service (LOS)** A qualitative measure describing operational conditions within a traffic stream, based on service measures such as speed, travel time, freedom to maneuver, traffic interruptions, comfort, and convenience. Six levels of service are defined for each type of facility that has analysis procedures available. Letters designate each level, from A to F, with LOS A representing the best operating conditions and LOS F the worst. Each level of service represents a range of operating conditions and the driver's perception of those conditions. Safety is not included in the measures that establish service levels.

**life cycle cost** The total cost of a project or item over its useful life. This includes all of the relevant costs that occur throughout the life of a project or item, including initial acquisition costs (such as right of way, planning, design, and construction), operation, maintenance, modification, replacement, demolition, financing, taxes, disposal, and salvage value as applicable.

**limited access (L/A)** Full, partial, or modified access control is planned and established for each corridor and then acquired as the right to limit access to each individual parcel (see [Chapter 520](#)).

- **acquired limited access control** Access rights have been purchased.
- **established limited access control** An access hearing has been held and the Assistant Secretary, Engineering & Regional Operations, has adopted the findings and order, which *establishes* the limits and level of control.
- **planned limited access control** Limited access control is planned for some time in the future; however, no access hearing has been held.

**Limited Access and Managed Access Master Plan** A map of Washington State that shows established and planned limited access highways: [www.wsdot.wa.gov/design/accessandhearings](http://www.wsdot.wa.gov/design/accessandhearings)

**limited access highway** All highways listed as “Established L/A” on the Limited Access and Managed Access Master Plan and where the rights of direct access to or from abutting lands have been acquired from the abutting landowners.

- **full access control** This most restrictive level of limited access provides access, using interchanges, for selected public roads/streets only, and prohibits highway intersections at grade.
- **partial access control** The second most restrictive level of limited access. At-grade intersections with selected public roads are allowed, and there may be some crossings and some driveway approaches at grade. Direct commercial access is not allowed.
- **modified access control** The least restrictive level of limited access. Characteristics are the same as for partial access control except that direct commercial access is allowed.

**local roads** Non-state highways that are publicly owned.

**low pavement type** Bituminous surface treatment (BST).

**low-speed roadway** A roadway with a posted speed of lower than 45 mph.

**lumen** The unit used to measure luminous flux.

**luminaire** A complete lighting unit comprised of a light bulb, wiring, and a housing unit.

**luminance** The quotient of the luminous flux at an element of the surface surrounding the point and propagated in directions defined by an elementary cone containing the given direction, by the product of the solid angle of the cone and area of the orthogonal projection of the element of the surface on a plane perpendicular to the given direction. The luminous flux may be leaving, passing through, and/or arriving at the surface.

**luminous flux** The time rate of the flow of light.

## **M**

**Major Project** A project receiving federal financial assistance (1) with an estimated cost of \$500 million or more, or (2) that has been identified by the Secretary as being "Major" as a result of special interest (23 U.S.C 106 (h)).

**managed access highway** Highways where the rights of direct access to or from abutting lands have not been acquired from the abutting landowners.

**managed lane** A lane that increases efficiency by packaging various operational and design actions. Lane management operations may be adjusted at any time to better match regional goals.

**maximum** The highest design value allowed without a deviation.

**maximum uniformity ratio** The average light level within the design area divided by the minimum light level within the design area (see [Chapter 1040](#)).

**maximum veiling luminance ratio** The maximum veiling luminance divided by the average luminance over a given design area for an observer traveling parallel to the roadway centerline (see [Chapter 1040](#)).

**mcd/m<sup>2</sup>/lux** Pavement marking retroreflectivity is represented by the coefficient of retroreflected luminance ( $R_r$ ) measured in millicandelas per square meter.

**median** The portion of a divided highway separating vehicular traffic traveling in opposite directions.

**median opening** An opening in a continuous median for the specific purpose of allowing vehicle movement.

**Memorandum of Understanding (MOU)** There is one MOU (*Highways Over National Forest Lands*) between the United States Forest Service (USFS) and WSDOT that requires the USFS to obtain a road approach permit for new access to a state highway that is crossing Forest Service land.

**metering signal** A signal used to control the predominant flow rate of traffic at an at-grade facility.

**Methods and Assumptions Document** A mandatory document developed at the beginning of the IJR phase to record IJR assumptions, methodologies, criteria, and decisions (see [Chapter 550](#)).

---

**Metropolitan Planning Organization (MPO)** A lead agency designated by the Governor to administer the federally required transportation planning process in a metropolitan area with a population over 50,000. The MPO is responsible for the 20-year long-range plan and Transportation Improvement Program (TIP).

**mil** Unit of measurement equivalent to 0.001 inches.

**minimum** The lowest design value allowed without a deviation.

**minimum average light level** The average of all light intensities within the design area, measured just prior to relamping the system (see [Chapter 1040](#)).

**minimum light level** The minimum light intensity of illumination at any single point within the design area measured just prior to relamping the system (see [Chapter 1040](#)).

**minor arterial system** A rural network of arterial routes linking cities and other activity centers that generate long distance travel and, with appropriate extensions into and through urban areas, form an integrated network providing interstate and interregional service ([RCW 47.05.021](#)).

**minor operational enhancement projects** These projects usually originate from the Q2 component of the Q Program and are quick responses to implement low-cost improvements. They are typically narrow in scope and focus on improvements to traffic operations and modifications to traffic control devices. Guidance on the type of work included in the Q subprograms is in the *Chart of Accounts*.

**monument** As defined in [Chapter 410](#), a monument is any physical object or structure that marks or references a survey point. This includes, but is not limited to, a point of curvature (P.C.), a point of tangency (P.T.), a property corner, a section corner, a General Land Office (GLO) survey point, a Bureau of Land Management (BLM) survey point, and any other permanent reference set by a governmental agency or private surveyor.

**monument removal or destruction** The physical disturbance or covering of a monument such that the survey point is no longer visible or readily accessible.

**mounting height – luminaire** The vertical distance between the surface of the design area and the center of the light source of the luminaire. Note: This is not to be confused with pole height (H1), but is the actual distance that the luminaire is located above the roadway edge line.

**movable bridge signal** (also drawbridge signal) A signal installed to notify traffic to stop when the bridge is opened for waterborne traffic. Movable bridge signals display continuous green when the roadway is open to vehicular traffic.

**multilane approach** An approach that has two or more lanes, regardless of the lane use designation.

**multimodal connection** The point where multiple types of transportation activities occur; for example, where transit buses and van pools drop off or pick up passengers (including passengers with bicycles).

## N

**National Highway System (NHS)** An interconnected system of principal arterial routes that serves interstate and interregional travel; meets national defense requirements; and serves major population centers, international border crossings, ports, airports, public transportation facilities, other intermodal transportation facilities, and other major travel destinations. The Interstate System is a part of the NHS.

**natural vehicle path** The natural path that a driver navigates a vehicle given the layout of the intersection and the ultimate destination.

**need** A statement that identifies the transportation problem(s) that the proposal is designed to address and explains how the problem will be resolved. An existing or anticipated travel demand that has been documented through a study process to require a change in access to the state's limited access freeway system.

**nighttime** The period of time from one-half hour after sunset to one-half hour before sunrise and any other time when persons or objects may not be clearly discernible at a distance of 500 feet ([RCW 46.04.200](#)).

**no-build condition** The baseline, plus state transportation plan and comprehensive plan improvements, expected to exist, as applied to the year of opening or the design year.

**nonconforming road approach** A road approach that does not meet current requirements for location, quantity, spacing, sight distance, or geometric elements.

**nonrecoverable slope** A slope on which an errant vehicle might continue until it reaches the bottom, without having the ability to recover control. Fill slopes steeper than 4H:1V, but not steeper than 3H:1V, are considered nonrecoverable.

**nonseparated HOV lane** An HOV lane that is adjacent to and operates in the same direction as the general-purpose lanes with unrestricted access between the HOV lane and the general-purpose lanes.

**notice of appearance** A form provided by WSDOT for anyone wanting to receive a copy of the findings and order and the adopted *limited access plan* (see [Chapter 210](#)).

**notice of hearing (or hearing notice)** A published advertisement that a public hearing will be held.

**notice of opportunity for a hearing** An advertised offer to hold a public hearing.

## O

**occupancy designation** The minimum number of occupants required for a vehicle to use the HOV facility.

**operating speed** The speed at which drivers are observed operating their vehicles during free-flow conditions. The 85<sup>th</sup> percentile of the distribution of observed speeds is most frequently used.

**order of hearing** The official establishment of a hearing date by the Director & State Design Engineer, Development Division.

**outer separation** The area between the outside edge of traveled way for through traffic and the nearest edge of traveled way of a frontage road or collector-distributor (C-D) road.

**overlapped displays** Overlapped displays allow a traffic movement to operate with one or more nonconflicting phases. Most commonly, a minor street's exclusive right-turn phase is overlapped with the nonconflicting major street's left-turn phase. An overlapped display can be terminated after the parent phase (the main phase the overlap is associated with) terminates. An overlapped display programmed for two or more parent phases continues to display until all of the parent phases have terminated. An overlap is made up of two or more phases—not one phase controlling two movements.

---

**P**

**painted nose** The point where the main line and ramp lanes separate.

**“pass-by” trips** Pass-by trips are intermediate stops between an origin and a primary trip destination; for example, home to work, home to shopping.

**passenger loading zone** An area provided for pedestrians to board/disembark a vehicle.

**passing lane** An auxiliary lane on a two-lane highway used to provide the desired frequency of passing zones.

**passing sight distance** The distance (on a two-lane highway) needed for a vehicle driver to execute a normal passing maneuver based on design conditions and design speed.

**pavement marking** A colored marking applied to the pavement to provide drivers with guidance and other information.

**peak hour** The 60-minute interval that contains the largest volume of traffic during a given time period. If a traffic count covers consecutive days, the peak hour can be an average of the highest hour across all of the days. An a.m. peak is simply the highest hour from the a.m., and the p.m. peak is the highest from the p.m. The peak hour correlates to the DHV, but is not the same. However, it is close enough on items such as intersection plans for approval to be considered equivalent.

**permit holder** The abutting property owner or other legally authorized person to whom an access connection permit is issued by the permitting authority.

**permitted access connection** A connection for which an access connection permit has been issued by a permitting authority.

**permitting authority** The agency that has legal authority to issue managed access connection permits. For access connections in unincorporated areas, the permitting authority is WSDOT; for access connections within corporate limits, the permitting authority is a city or town.

**physical nose** The point, upstream of the gore, with a separation between the roadways of 16 to 22 feet (see [Chapter 1360](#)).

**planning** Transportation planning is a decision-making process required by federal and state law used to solve complex, interrelated transportation and land use problems (see [Chapter 120](#)).

**Plans, Specifications, and Estimates (PS&E)** The project development activity that follows Project Definition and culminates in the completion of contract-ready documents and the engineer’s cost estimate.

**pole height (H1)** The vertical distance from the light source to the pole base. This distance is specified in contracts and used by the pole manufacturers to fabricate the light standard.

**policy point** There are eight policy points addressed in the IJR:

- Need for the Access Point Revision
- Reasonable Alternatives
- Operational & Collision Analyses
- Access Connections & Design
- Land Use & Transportation Plans
- Future Interchanges
- Coordination
- Environmental

**portable traffic signal** A type of conventional traffic signal used in work zones to control traffic. This signal is most commonly used on two-way two-lane highways where one lane has been closed for roadwork. This signal is most commonly operated in pairs, with one signal at each end of the work zone. This eliminates the need for 24-hour flagger control. The traffic signal provides alternating right of way assignments for conflicting traffic movements. The signal has an adjustable vertical support with two three-section signal displays and is mounted on a mobile trailer with its own power source.

**posted speed** The maximum legal speed as posted on a section of highway using regulatory signs.

**prehearing packet** A concise, organized collection of all necessary prehearing data, prepared by the region and approved by the HQ Development Services & Access Manager prior to the hearing (see [Chapter 210](#)).

**preliminary engineering (PE)** A term used to describe the Project Delivery process from project scoping through PS&E review.

**principal arterial system** A connected network of rural arterial routes with appropriate extensions into and through urban areas, including routes designated as part of the Interstate System, that serves corridor movements with travel characteristics indicative of substantial statewide and interstate travel ([RCW 47.05.021](#)).

**priority array** A collection of similar needs identified in the HSP, prioritized based on the methodology adopted by WSDOT to meet the requirements of [RCW 47.05](#).

**Priority Array Tracking System (PATS)** A database that allows tracking of highway needs and their solutions. The system is designed to ensure WSDOT addresses the highest-ranked transportation needs. Deficiencies are tracked for each strategy in the HSP.

**product or service** Any element of a project from concept through maintenance and operation. In all instances, the required function should be achieved at the lowest life cycle cost based on requirements for performance, maintainability, safety, environment, and aesthetics.

**project** A portion of a highway that WSDOT or a public authority proposes to construct, reconstruct, or improve as described in the preliminary design report or applicable environmental document. A project is roadway/highway improvement within the logical termini identified in the environmental document and may consist of several contracts, or phases of a project or contract, that are implemented over several years.



**Project Analysis** Documentation that justifies a change in design level and/or decisions to include, exclude, or modify design elements specific to a project only (see also [Chapter 1100](#)).

**Project Change Request Form** A form used to document and approve revisions to project scope, schedule, or budget from a previously approved Project Definition (see [Project Summary](#)). Include copies in the Design Documentation Package.

**Project Control and Reporting (PC&R)** The Headquarters (HQ) Project Control and Reporting Office is responsible for monitoring, tracking, and reporting delivery of the Highway Construction Program in coordination with the Program Management offices in each of the six WSDOT regions and the Urban Corridors Office.

**Project Definition** (see [Project Summary](#))

**Project Development Approval** Final approval of all project development documents by the designated representative of the approving organization prior to the advertisement of a capital transportation project (see [Chapter 300](#)).

**Project Engineer** This term applies to WSDOT personnel. Wherever “Project Engineer” appears in this manual, the design-builder shall deem it to mean “Engineer of Record.”

**Project File (PF)** A file containing all documentation and data for all activities related to a project (see [Chapter 300](#)).

- **Design Documentation Package (DDP)** The portion of the Project File, including Design Approval and Project Development Approval, that will be retained long term in accordance with WSDOT document retention policies. Depending on the scope of the project, it contains the Project Summary and some or all of the other documents discussed in [Chapter 300](#). Technical reports and calculations are part of the Project File, but they are not designated as components of the DDP. Include estimates and justifications for decisions made in the DDP (see [Chapter 300](#)). The DDP explains how and why the design was chosen and documents approvals.

**project management plan** A formal, approved document that defines how the project is executed, monitored, and controlled. It may be in summary or detailed form and may be composed of one or more subsidiary management plans and other planning documents. For further information, see the *Project Management Online Guide*: [www.wsdot.wa.gov/Projects/ProjectMgmt/PMOG.htm](http://www.wsdot.wa.gov/Projects/ProjectMgmt/PMOG.htm)

**Project Scoping** See [Chapter 300](#).

**Project Summary** A set of documents consisting of the Design Decisions (DD), Environmental Review Summary (ERS), and Project Definition (PD). The Project Summary is part of the design documentation required to obtain Design Approval and is ultimately part of the design documentation required for Project Development Approval (see [Chapter 300](#)).

- **Design Decisions (DD)** A document that records major design decisions regarding roadway geometrics, roadway and roadside features, and other issues that influence the project scope and budget.
- **Environmental Review Summary (ERS)** A document that records the environmental classification (class of action) and considerations (consequences of action) for a specific project.
- **Project Definition (PD)** A document that records the purpose and need of the project, along with program level and design constraints.

**proposal** The combination of projects/actions selected through the study process to meet a specific transportation system need.

**public art** An enhancement to a functional element, feature, or place within a transportation facility to provide visual interest. The enhancement could be an addition to a functional element, integrated into a design, or for purely aesthetic purposes. An element is considered “public art” if it is beyond WSDOT standard practice for architectural treatment.

**public involvement plan** A plan to collaboratively involve the public in decision making, tailored to the specific needs and conditions of a project and the people and communities it serves. It is often part of a broader communications plan.

**public transportation** Passenger transportation services available to the public, including buses, ferries, rideshare, and rail transit.

**purpose** General project goals such as improve safety, enhance mobility, or enhance economic development.

## Q

**queue cutter traffic signal** A traffic signal used at highway-rail grade crossings where the queue from a downstream traffic signal is expected to extend within the Minimum Track Clearance Distance. It is used to keep vehicles from an adjacent signalized intersection from queuing on the railroad tracks.

## R

**ramp connection** The pavement at the end of a ramp, connecting to a main lane of a roadway.

**ramp (in relation to a roadway)** A short roadway connecting a main lane of a highway with another facility, such as a road, parking lot, or transit stop, for vehicular use.

**ramp meter** A traffic signal at a freeway entrance ramp that allows a measured or regulated amount of traffic to enter the freeway.

**ramp terminal** An intersection at the end of a ramp.

**Record of Decision (ROD)** Under the National Environmental Policy Act, the Record of Decision accompanies the Final Environmental Impact Statement; explains the reasons for the project decision; discusses alternatives and values considered in selection of the preferred alternative; and summarizes mitigation measures and commitments that will be incorporated in the project.

**recoverable slope** A slope on which the driver of an errant vehicle can regain control of the vehicle. Slopes of 4H:1V or flatter are considered recoverable.

**recovery area** The minimum target value used in highway design when a fill slope between 4H:1V and 3H:1V starts within the Design Clear Zone.

**Recreational Vehicle Account** In 1980 the RV account was established for use by the department of transportation for the construction, maintenance, and operation of recreational vehicle sanitary disposal systems at safety rest areas ([RCW 46.68.170](#)). A recreational vehicle sanitary disposal fee is required for registration of a recreational vehicle ([RCW 46.17.375](#)). Adjustments to the recreational vehicle fee by the department of transportation may be implemented after consultation with the citizens’ representatives of the recreational vehicle user community ([RCW 47.01.460](#)).

**Regional Transportation Planning Organization (RTPO)** A planning organization authorized by the Legislature in 1990 as part of the Growth Management Act. The RTPO is a voluntary organization with representatives from state and local governments that are responsible for coordinating transportation planning activities within a region.

**relocation assistance program** A program that establishes uniform procedures for relocation assistance that will ensure legal entitlements and provide fair, equitable, and consistent treatment to persons displaced by WSDOT-administered projects, as defined in the [Right of Way Manual](#).

**Request for Proposal (RFP)** The document package issued by WSDOT requesting submittal of proposals for the project and providing information relevant to the preparation and submittal of proposals, including the instructions to proposers, contract documents, bidding procedures, and reference documents.

**rest area** An area to the side of a path.

**résumé** An official notification of action taken by WSDOT following adoption of a findings and order (see [Chapter 210](#)).

**retroreflection** The phenomenon of light rays striking a surface and being returned directly back to the source of light.

**retroreflectometer** An instrument used to measure retroreflectivity.

**right of way (R/W)** A general term denoting land or interest therein, acquired for or designated for transportation purposes. More specifically, lands that have been dedicated for public transportation purposes or land in which WSDOT, a county, or a municipality owns the fee simple title, has an easement devoted to or required for use as a public road/street and appurtenant facilities, or has established ownership by prescriptive right.

**right of way and limited access plan (R/W and L/A plan)** A right of way plan that also shows limited access control details.

**road approach** An access point, other than a public road/street, that allows access to or from a limited access highway on the state highway system.

**road approach design template** The design geometric criteria for a road approach based on the usage, types of vehicles, and traffic volume.

**roadside park** A roadside user facility for safe vehicular parking off the traveled way and separated from the highway by some form of buffer. These sites might be equipped with features or elements such as points of interest, picnic tables, and/or vault toilet buildings. Unlike a safety rest area, a roadside park does not always provide a permanent restroom building.

**roadway** The portion of a highway, including shoulders.

**roadway luminance** The light projected from a luminaire that travels toward a given area, represented by a point on the pavement surface, and then back toward the observer, opposite to the direction of travel. The units of roadway luminance are footcandles.

**roundabout** A circular intersection at grade with yield control of all entering traffic, channelized approaches with raised splitter islands, counter-clockwise circulation, and appropriate geometric curvature to force travel speeds on the circulating roadway generally to less than 25 mph.

**rumble strips** Rumble strips are grooves or rows of raised pavement markers placed perpendicular to the direction of travel to alert inattentive drivers.

**rural design area** An area that meets none of the conditions to be an urban design area.

**rural intersection** An intersection in a rural design area (see [Chapter 1140](#)).

## S

**safety rest area (SRA)** A roadside facility equipped with permanent restroom building(s), a parking area, picnic tables, refuse receptacles, illumination, and other ancillary services. SRAs typically include potable water and might include traveler information and telephones.

**Safety Rest Area Strategic Plan** Developed in 2008 under a stakeholder-coordinated effort of executive and advisory team members, this plan provides guidance for current and future management of the SRA program.

**sawtooth berth** A series of bays that are offset from one another by connecting curb lines, constructed at an angle from the bus bays. This configuration minimizes the amount of space needed for vehicle pull in and pull out.

**scoping phase** The first phase of project development for a specific project, the scoping phase follows identification of the need for a project and precedes detailed project design. It is the process of identifying the work to be done and developing a cost estimate for completing the design and construction. The Project Summary, engineering and construction estimates, and possibly several technical reports (geotechnical, surfacing, bridge condition, and so on) are developed during this phase.

**security lighting** A minimal amount of lighting used to illuminate areas for public safety or theft reduction. Security lighting for walkways is the lighting of areas where shadows and horizontal and vertical geometry obstruct a pedestrian's view.

**"select zone" analysis** A traffic model run, where the related project trips are distributed and assigned along a populated highway network. This analysis isolates the anticipated impact on the state highway network created by the project.

**separated HOV facility** An HOV roadway that is physically separated from adjacent general-purpose lanes by a barrier or median, or is on a separate right of way.

**service life** The service life of a pavement marking is the time or number of traffic passages required for its retroreflectivity to decrease from its initial value to a minimum threshold value indicating that the marking needs to be refurbished or replaced.

**shared roadway** A roadway that is open to both bicycle and motor vehicle travel. This may be a new or existing roadway/highway, a street with wide curb lanes, or a road with paved shoulders.

**shared-use landing** A level (0 to 2% grade cross slope and running slope) paved area within the shared-use path, designed to provide turning and maneuvering space for wheelchair users and as a resting place for pedestrians.

**shared-use path** A facility physically separated from motorized vehicular traffic within the highway right of way or on an exclusive right of way with minimal crossflow by motor vehicles. Shared-use paths are primarily used by bicyclists and pedestrians, including joggers, skaters, and pedestrians with disabilities, including those who use nonmotorized or motorized wheeled mobility devices. With appropriate design considerations, equestrians may also be accommodated by a shared-use path facility.

**shoulder** The portion of the roadway contiguous with the traveled way, primarily for accommodation of stopped vehicles, emergency use, lateral support of the traveled way, and where allowed, use by pedestrians and bicycles.

**shoulder width** The lateral dimension of the shoulder, measured from the edge of traveled way to the edge of roadway or the face of curb.

**shy distance** The distance from the edge of the traveled way beyond which a roadside object might not be perceived by a typical driver as an immediate feature to be avoided to the extent that the driver will change the vehicle's placement or speed.

**sight distance** The length of highway visible to a driver.

**Signal Maintenance Management System (SIMMS)** A database used for traffic signals, illumination, and Intelligent Transportation Systems (ITS). SIMMS is used to establish an inventory base, enter work reports, print timesheets, and store maintenance records for electrical/electronics systems within WSDOT right of way.

**signed shared roadway** A shared roadway that has been designated by signing as a route for bicycle use.

**single-lane roundabout** A roundabout having single-lane entries at all legs and one circulating lane.

**single-occupant vehicle (SOV)** Any motor vehicle other than a motorcycle carrying one occupant.

**site** A parcel of land bounded by a property line or a designated portion of a public right of way.

**slip base** A mechanical base designed to allow the light standard to break away from the fixed foundation when hit by a vehicle traveling at the design speed.

**slip lane** A lane that separates heavy right-turn movements from the roundabout circulating traffic (see [Chapter 1320](#)).

**slip ramp** A connection between legs of an intersection that allows right-turning vehicles to bypass the intersection or a connection between an expressway and a parallel frontage road. These are often separated by an island.

**slow-moving vehicle turnout** A shoulder area widened to provide room for a slow-moving vehicle to pull out of the through traffic, allow vehicles to pass, and then return to the through lane.

**spacing** The distance in feet measured on centerline between adjacent luminaires.

**speed limit sign beacon** A beacon installed with a fixed or variable speed limit sign. The preferred display is two flashing yellow indications.

**splitter island** The raised island at each two-way leg between entering and exiting vehicles, designed primarily to control the entry and exit speeds by providing deflection. They also discourage wrong-way movements, and provide pedestrian refuge.

**spraying** A procedure for applying marking material to a surface as a jet of fine liquid particles.

**state highway system** All roads, streets, and highways designated as state routes in compliance with [RCW 47.17](#).

**Statewide Transportation Improvement Program (STIP)** A planning document that includes all federally funded projects and other regionally significant projects for a three-year period.

**static scale** A scale that requires a vehicle to stop for weighing.

**stopping sight distance** The distance needed for a driver to stop a vehicle traveling at design speed based on design conditions.

**stop sign beacon** A beacon installed above a stop sign. The display is a flashing red indication.

**study area** The transportation system area to study in the study process and for an IJR. The study area is a minimum of one interchange upstream and downstream from the proposal. The study area shall also include the intersecting roadway in the area to the extent necessary to ensure its ability to collect and distribute traffic to and from the interchange. The study area should be expanded as necessary to capture operational impacts of adjacent interchanges in the vicinity that are, or will be, bottlenecks or chokepoints that influence the operations of the study interchange.

**study plan** A term associated with environmental procedures, this plan proposes an outline or “road map” of the environmental process to be followed during the development of a project that requires complex NEPA documentation (see [Chapter 210](#) and the [Environmental Procedures Manual](#)).

**suburban area** A term for the area at the boundary of an urban design area. Suburban settings may combine higher speeds common in rural design areas with activities more common to urban settings.

**superelevation** The rotation of the roadway cross section in such a manner as to overcome part of the centrifugal force that acts on a vehicle traversing a curve.

**superelevation runoff** The length of highway needed to accomplish the change in cross slope from a section with adverse crown removed (level) to a fully superelevated section, or vice versa.

**superelevation transition length** The length of highway needed to change the cross slope from normal crown or normal pavement slope to full superelevation.

**support team** An integral part of the IJR process consisting of an assemblage of people from the regions, FHWA (for Interstates), WSDOT HQ Access and Hearings, and other representatives organized to develop and analyze alternatives to meet the need of a proposal, including approval authorities.

**Surface Transportation Program (STP)** A federal program established by Congress in 1991 that provides a source of federal funding for highway and bridge projects.

---

**T**

**tangent runoff** The length of highway needed to change the cross slope from normal crown to a section with adverse crown removed (level).

**temporary traffic signal** A conventional traffic signal used during construction to control traffic at an intersection while a permanent signal system is being constructed. A temporary traffic signal is typically an inexpensive span-wire installation using timber strain poles.

**Total Project Costs** The costs of all phases of a project, including environmental, design, right of way, utilities, and construction.

**traffic barrier** A longitudinal barrier, including bridge rail or an impact attenuator, used to redirect vehicles from fixed features located within an established Design Clear Zone, help mitigate median crossovers, reduce the potential for errant vehicles to travel over the side of a bridge structure, or (occasionally) protect workers, pedestrians, or bicyclists from vehicular traffic.

**traffic barrier/longitudinal barrier** A device oriented parallel or nearly parallel to the roadway whose primary function is to contain or safely redirect errant vehicles away from fixed features or to (occasionally) protect workers, pedestrians, or bicyclists from vehicular traffic. Beam guardrail, cable barrier, bridge rail, concrete barrier, and impact attenuators are barriers, and they are categorized as rigid, rigid anchored, unrestrained rigid, semirigid, and flexible. They can be installed as roadside or median barriers.

**traffic calming** Design techniques that have been shown to reduce traffic speeds and unsafe maneuvers. These techniques can be stand-alone or used in combination, and they include lane narrowing, curb extensions, surface variations, and visual clues in the vertical plane.

**traffic paint** A pavement marking material that consists mainly of a binder and a solvent. The material is kept in liquid form by the solvent, which evaporates upon application to the pavement, leaving the binder to form a hard film.

**transit** A general term applied to passenger rail and bus service used by the public.

**transit facility** A capital facility that improves the efficiency of public transportation or encourages the use of public transportation.

**transit flyer stop** A multimodal connection located within the boundaries of a limited access facility.

**transition** A section of barrier used to produce the gradual stiffening of a flexible or semirigid barrier as it connects to a more rigid barrier or fixed object.

**transit lane** A lane for the exclusive use of transit vehicles.

**transit stop** A facility for loading and unloading passengers that is set aside for the use of transit vehicles only.

**transit vehicle** A bus or other motor vehicle that provides public transportation (usually operated by a public agency).

**Transportation Improvement Program (TIP)** A three-year transportation improvement strategy required from MPOs by Congress, which includes all federally funded or regionally significant projects.

**Transportation Information and Planning Support (TRIPS)** A mainframe computer system designed to provide engineering, maintenance, planning, and accounting staff with highway inventory, traffic, and accident data.

**Transportation Management Area (TMA)** Urbanized areas with populations of 200,000 or greater are federally designated as Transportation Management Areas.

**transportation management plan (TMP)** A set of traffic control plans, transportation operations plans, and public information strategies for managing the work zone impacts of a project. A TMP is required for all projects to address work zone safety and mobility impacts.

**Transportation Planning Studies** These studies identify the current functions of a corridor and forecast future demands on the system. Data collection and public involvement are used to forecast future needs that will improve the function of a state route.

**travel demand** The demand travelers will make on the system based on the number and types of trips they will take and the mode and routes they will use. Local travel demand represents short trips that should be made on the local transportation system, such as intracity roads and streets. Regional travel demand represents long trips that are made on the regional transportation system, such as Interstate, regional, and/or intercity/interregional roads, streets, or highways.

**traveled way** The portion of the roadway intended for the movement of vehicles, exclusive of shoulders and lanes for parking, turning, and storage for turning.

**traveler information** Commercial and noncommercial information that informs and orients the traveling public. This includes access information for food, gas, lodging, local attractions, regional tourist attractions, roadway conditions, and construction schedules.

**traveling public** Motorists, motorcyclists, bicyclists, pedestrians, and pedestrians with disabilities.

**trips** Short trips are normally local. Long trips are normally interstate, regional, or interregional.

**truck apron** The optional mountable portion of the central island of a roundabout between the raised nontraversable area of the central island and the circulating roadway (see [Chapter 1320](#)).

**turning radius** The radius that the front wheel of the design vehicle on the outside of the curve travels while making a turn (see [Chapter 1320](#)).

**turning roadway** A curve on an open highway, a ramp, or the connecting portion of the roadway between two intersecting legs of an intersection.

**two-way left-turn lane (TWLTL)** A lane, located between opposing lanes of traffic, to be used by vehicles making left turns from either direction, from or onto the roadway.

## U

**undivided multilane** A roadway with two or more through lanes in each direction on which left turns are not controlled.

**uniformity ratio** The ratio of the minimum average light level on the design area to the minimum light level of the same area (see [Chapter 1040](#)).



**urban area** An area designated by the Washington State Department of Transportation (WSDOT) in cooperation with the Transportation Improvement Board (TIB) and Regional Transportation Planning Organizations (RTPO), subject to the approval of the Federal Highway Administration (FHWA).

**urban design area** An area where urban design criteria are appropriate, that is defined by one or more of the following:

- An urban area.
- An area within the limits of an incorporated city or town.
- An area characterized by intensive use of the land for the location of structures, that receives urban services such as sewer, water, and other public utilities, as well as services normally associated with an incorporated city or town. This may include an urban growth area defined under the Growth Management Act (see [RCW 36.70A](#), Growth management – Planning by selected counties and cities), but outside the city limits.
- An area with not more than 25% undeveloped land.

**urban intersection** An intersection in an urban design area (see [Chapter 1140](#)).

**urbanized area** An urban area with a population of 50,000 or more.

**usable shoulder** The width of the shoulder that can be used by a vehicle for stopping.

## V

**Value Engineering (VE) Analysis** The systematic process of reviewing and assessing a project, during the planning and design phases, by a multidisciplinary team not directly involved in the planning and design phases of the project, that follows the VE Job Plan and is conducted to provide recommendations for:

- Providing the needed functions, considering community and environmental commitments, safely, reliably, efficiently, and at the lowest overall life cycle cost.
- Improving the value and quality of the project.
- Reducing the time to develop and deliver the project.

**Value Engineering Change Proposal (VECP)** A construction contract change proposal submitted by the construction contractor based on a VECP provision in the contract. The intent of these types of proposals is to (1) improve the project's performance, value, and/or quality, (2) lower construction costs, or (3) shorten the delivery time, while considering their impacts on the project's overall life-cycle cost and other applicable factors.

**Value Engineering (VE) Job Plan** A systematic and structured action plan (see [Chapter 310](#)) for conducting and documenting the results of the VE analysis. While each VE analysis shall address each phase in the VE Job Plan, the level of analysis conducted and effort expended for each phase should be scaled to meet the needs of each individual project. The VE Job Plan shall include and document the following seven phases:

1. Information Phase: Gather project information, including project commitments and constraints.
2. Function Analysis Phase: Analyze the project to understand the required functions.
3. Creative Phase: Generate ideas on ways to accomplish the required functions, which improve the project's performance, enhance its quality, and lower project costs.
4. Evaluation Phase: Evaluate and select feasible ideas for development.
5. Development Phase: Develop the selected alternatives into fully supported recommendations.
6. Presentation Phase: Present the VE recommendation to the project stakeholders.
7. Resolution Phase: Evaluate, resolve, document, and implement all approved recommendations.

Post-analysis Job Plan activities include the implementation and evaluation of the outcomes of the approved recommendations. These post-analysis phases are conducted in accordance with the policies stated below and as described in paragraph 4f of FHWA Order 1311.1A, FHWA Value Engineering Policy.

**veiling luminance** The stray light produced within the eye by light sources produces a veiling luminance that is superimposed on the retinal image of the objects being observed. This stray light alters the apparent brightness of an object within the visual field and the background against which it is viewed, thereby impairing the ability of the driver to perform visual tasks. Conceptually, veiling luminance is the light that travels directly from the luminaire to the observer's eye.

**viewpoint** A roadside stopping opportunity with a view of some point of interest or area scenery. This area is not typically separated from the traveled way by some form of highway buffer.

**violation rate** The total number of violators divided by the total number of vehicles on an HOV facility.

**Visitor Information Center (VIC)** A staffed or nonstaffed booth or separate building that displays and dispenses free tourist travel maps and brochures. These are typically located at border-entry SRAs to provide travel information to highway users as they enter the state.

## W

**warning beacon** A beacon that supplements a warning or regulatory sign or marking. The display is a flashing yellow indication. These beacons are not used with STOP, YIELD, or DO NOT ENTER signs or at intersections that control two or more lanes of travel. A warning identification beacon is energized only during those times when the warning or regulation is in effect.

**warrant** A minimum condition for which an action is authorized. Meeting a warrant does not attest to the existence of an unsafe or undesirable condition. Further justification is required.

**Washington State Pavement Management System (WSPMS)** A computer system that stores data about the pavement condition of all the highways in the state. Information available includes the latest field review and past contracts for every main line mile of state highway. Calculations are used to determine whether a given section of pavement is a past due, due, or future due preservation need.

**Washington Transportation Plan (WTP)** A WSDOT planning document developed in coordination with local governments, regional agencies, and private transportation providers. The WTP addresses the future of transportation facilities owned and operated by the state as well as those the state does not own but in which it has an interest. It identifies needed transportation investments, which are defined by service objectives and specific desired outcomes for each transportation mode.

**weaving section** A length of highway over which one-way traffic streams cross by merging and diverging maneuvers.

**weigh in motion (WIM)** A scale facility capable of weighing a vehicle without the vehicle stopping.

**wet film thickness** Thickness of a pavement marking at the time of application without glass beads.

**work zone** An area of a highway with construction, maintenance, or utility work activities. A work zone is identified by the placement of temporary traffic control devices that may include signs, channelizing devices, barriers, pavement markings, and/or work vehicles with warning lights. It extends from the first warning sign or high-intensity rotating, flashing, oscillating, or strobe lights on a vehicle to the END ROAD WORK sign or the last temporary traffic control device ([MUTCD](#)).

**work zone impact** Highway construction, maintenance, or utility work operations in the traveled way, adjacent to the traveled way, or within the highway's right of way that creates safety and mobility concerns for workers or the traveling public.

**work zone traffic control** The planning, design, and preparation of contract documents for the modification of traffic patterns due to work zone impacts.

**wye (Y) connection** An intersecting one-way roadway, intersecting at an angle less than 60°, in the general form of a "Y."

## Y

**yield-at-entry** The requirement that vehicles on all entry lanes yield to vehicles within the circulating roadway.

**yield point** The point at which entering traffic must yield to circulating traffic before entering the circulating roadway (see [Chapter 1320](#)).

