

PANEL ASSESSMENT OF INTERSTATE BRIDGES SEISMIC VULNERABILITIES

Draft Technical Report

December 18, 2006





Title VI

The Columbia River Crossing project team ensures full compliance with Title VI of the Civil Rights Act of 1964 by prohibiting discrimination against any person on the basis of race, color, national origin or sex in the provision of benefits and services resulting from its federally assisted programs and activities.

Americans with Disabilities Act (ADA) Information

If you would like copies of this document in an alternative format, or are deaf or hard of hearing, please call the Columbia River Crossing Project office at (360) 737-2726 or (503) 256-2726.

TABLE OF CONTENTS

1. EXECUTIVE SUMMARY	1-1
2. INTRODUCTION	2-1
2.1 Use of an Expert Review Panel as a First Screening Step.....	2-1
2.2 Relevant Background Information of the Structures	2-3
2.3 Previous Seismic Study.....	2-4
3. SEISMIC RETROFIT CRITERIA	3-1
3.1 Study Events – Return Periods	3-2
4. APPROACH TO EVALUATION	4-1
4.1 Conceptual Retrofit.....	4-1
5. COST OPINIONS	5-1
6. NEXT STEPS	6-1
6.1 Other issues for consideration.....	6-1
7. SUMMARY	7-1
APPENDIX A – MEETING SUMMARY	A-1
APPENDIX B – SEISMIC PANEL PRESENTATION, AUGUST 29, 2006	B-1
APPENDIX C – RESULTS OF WSDOT LIQUEFACTION ANALYSIS	C-1

List of Figures

Figure 4-1. Foundation and Pier Retrofit Alternative 1	4-2
Figure 4-2. Foundation and Pier Retrofit Alternative 2	4-3

List of Tables

Table 2-1 Seismic Expert Panel Members	2-2
Table 2-2 Others Attending All or Parts of Meetings	2-2

This page intentionally left blank.

1. Executive Summary

The Columbia River Crossing (CRC) project convened a panel of bridge and geotechnical engineers (the Panel) with relevant seismic design and retrofit experience to consider and discuss critical issues concerning the seismic vulnerability and retrofit possibilities of the existing I-5 Interstate Bridges.

The Panel was asked by the CRC project team to specifically address three questions. The questions and the responses from the Panel are as follows:

1. *Is it feasible to retrofit the existing structures? If so, how?*

Yes, it is technically feasible to retrofit the existing bridges to the current seismic safety standards. The Panel identified expected vulnerable elements of the bridges and discussed potential retrofit concepts to address these vulnerabilities. Retrofit concepts could include strengthening or replacing significant portions of the existing bridges.

2. *How would a retrofit affect the existing structure with regard to 4(f) sensitivities?*

For the purpose of protecting the structures' historic significance, the design effort can minimize changes in the structures' appearance. Examples of this include:

- Foundation and pier strengthening could follow the outline of the existing bridge elements, and although the resulting elements would be larger, there would be minimal visual impact.
- Bearing retrofit or replacement would be virtually unnoticeable to the untrained eye.
- If truss member strengthening and tower reconstruction is required, member shapes could be reasonably replicated.

3. *What is the cost to seismically upgrade the existing bridges?*

The Panel discussed and developed their opinion of estimated raw bridge construction costs to retrofit both bridges. This opinion ranges from \$88 million to \$190 million. This opinion of cost increases from \$125 million to \$265 million when design, permitting, right-of-way, construction inspection and management, agency oversight, and contingencies are added. (Note: The Expert Panel determined an opinion on ranges of construction costs and did not estimate the added costs.)

Discussion of these issues and others, including recommended next steps for more clearly defining the retrofit, if needed, are developed in more detail in the body of this report.

This page intentionally left blank.

2. Introduction

As part of the Alternatives Analysis, the CRC project team will recommend which alternatives to drop and which to carry forward into the Draft Environmental Impact Statement (DEIS). These recommendations will include narrowing the river crossing options, with a key choice being whether to remove or keep the existing bridges over the Columbia River. The “replacement” alternatives would remove the existing I-5 bridges and build new structures. The “supplemental” alternatives would keep the existing bridges in addition to building a new structure.

One of the key factors in considering the "reuse" of the existing bridges (in the Supplemental Alternatives) will depend on the required level of seismic upgrading to withstand loss or significant damage from a major earthquake, and meet the current standards for highway bridges. Questions that need to be answered include:

1. What is the seismic vulnerability of the existing bridges?
2. Is it feasible to retrofit them to current seismic safety standards?
3. What retrofit would be needed for the various uses (interstate, arterial, Bus Rapid Transit, Light Rail, bike/pedestrian)?
4. How would these upgrades change the bridges' appearance?
5. What is the cost to seismically upgrade the existing bridges?

Limited existing information is available to answer these questions. In 1995, ODOT contracted with DGES, Inc. to perform a limited seismic vulnerability study which concentrated on the lift spans, truss span pier foundations, and the typical span bearings. This study did not include subsurface investigation or foundation analysis. Cost estimates were based on information developed in the study and simple extrapolation to the entire structure. This gross approximation of the vulnerability is considered in the Panel’s discussions and referenced occasionally in this report.

2.1 Use of an Expert Review Panel as a First Screening Step

The CRC project team convened a Panel of experts with relevant experience in seismic retrofit projects to conduct a “reasonableness” response to the above questions. CRC project team members from David Evans and Associates, Inc. (DEA) and Parsons Brinckerhoff (PB), under Professional Services Consultant Agreement No. Y 9245 with the Oregon Department of Transportation (ODOT) and the Washington Department of Transportation (WSDOT), organized and assembled the Panel members.

In a two-day workshop held August 28 and 29, 2006, the Panel considered the potential and expected seismic risks and provided conceptual retrofit solutions and an opinion of the construction costs associated with the concepts. To estimate the construction costs for the Alternatives Analysis, approximations of member size, extent of retrofitting, and unit cost averages from similar retrofit projects were used.

The Panel members and their role in the project are listed in Table 2-1. Table 2-2 lists workshop attendees who were observers.

Table 2-1 Seismic Expert Panel Members

Participants	ROLE	ORGANIZATION
Jugesh Kapur, P.E., S.E.	State Bridge Engineer	Washington DOT
Bruce Johnson, P.E., S.E.	State Bridge Engineer	Oregon DOT
Bill Hegge, P.E.	Geotechnical Engineer	Washington DOT
Jan Six, P.E.	Geotechnical Engineer	Oregon DOT
Tim Rogers, P.E.	FHWA Bridge Engineer	OR-FHWA
Mark Hirota, P.E.	Chief CRC Bridge Engineer	Columbia River Crossing/PB
Frieder Seible, P.E.	Panel Consultant, Bridge Engineer	David Evans & Assoc.
Steve Thoman, P.E., S.E.	Panel Consultant, Bridge Engineer	David Evans & Assoc.
Farid Nobari, P.E.	Panel Consultant, Bridge Engineer	Parsons Brinckerhoff
Joe Wang, P.E.	Panel Consultant	Parsons Brinckerhoff
Thomas Cooper, P.E.	River Crossing Bridge Design Engineer	Columbia River Crossing/PB

Table 2-2 Others Attending All or Parts of Meetings

ATTENDEES	ROLE	ORGANIZATION
Kris Strickler, P.E.	Deputy Project Director	CRC
Lynn Rust, P.E.	Engineering Manager	CRC
Frank Green, P.E.	Assistant Engineering Manager	CRC
Jay Lyman, P.E.	Project Manager	CRC/DEA
Ron Anderson, P.E.	Deputy Project Manager	CRC/DEA
Tom Hildreth, P.E.	CRC Engineering Manager	CRC/PB
John Horne, P.E.	Geotechnical Engineer	PB
Matt Deml, P.E.	Senior Bridge Engineer	CRC/PB

This report documents the results of the Panel’s discussions during the workshop and summarizes the conclusions and recommendations of the Panel.

2.2 Relevant Background Information of the Structures

The northbound bridge was built in 1917, originally with a flat grade. It was the first bridge built across the Columbia River and is listed in the National Register of Historic Structures. The through-truss superstructure is comprised of laced steel members, which are typical for structures of that era.

The southbound bridge, which is similar to the 1917 bridge, was built in 1958. Instead of laced steel members, the superstructure consists of perforated steel plates. This was also typical for structures of this era. At the same time, the 1917 structure was revised to provide for a better (higher and wider) ship channel. This reconstruction work included replacing two short spans with one long span and adding the hump, to make the older structure configurations compatible with the southbound structure.

Both bridges include an operable vertical lift span at the northern end near the Vancouver shore. The bridges' superstructures are supported on rocker bearings, concrete piers, and timber piles that extend into the alluvium river bed material, but not to rock.

There is little to no information available for the foundation and pier construction of the 1917 bridge. As a result, there is little or no information regarding the pile capacity and pile tip elevations. There is also little or no data on reinforcement in the piers, so the level of seismic performance can only be estimated from the reinforced concrete jacket applied during the 1958 retrofit. Pile records were available for the 1958 bridge and the remedial pile foundation work performed on the 1917 bridge at this time. These records include "As-Constructed" pile tip elevations and this information was very useful in evaluating the effects of liquefaction on the lateral stability of both existing bridges.

As a part of the regular ODOT bridge inspection process, some investigation of the existing footings/scour holes has been done. These investigations include the following observations:

- Pile caps (underwater) have 3 feet to 27 feet of exposure.
- There is no visible undermining of the pile caps.
- No piles are exposed.

Potential Alternatives for the Columbia River Crossing Project

The Alternatives Analysis has identified 12 Alternatives for crossing the Columbia River. Alternatives 1 and 2 consider no action or only Transportation System Management (TSM) improvements and do not include any structural modifications. Alternatives 3 through 7 keep and reuse the existing structures in some capacity – either for carrying mainline I-5 (Alternative 3) or in conjunction with a supplemental structure to carry some portion of I-5 traffic and/or other modes of transportation such as light rail, buses, pedestrians, local roadway, etc. Only Alternative 3 places all of the mainline I-5 traffic on the existing structures.

Alternatives 8 through 12 call for removal of the existing structures and replacement with new structures to carry all modes of transportation required.

2.3 Previous Seismic Study

In 1995, ODOT commissioned David Goodyear Engineering Services, Inc. (DGES, Inc.) to carry out an abbreviated and simplified study of the seismic performance of the bridges. The scope of the study did not include liquefaction assessment, soil structure interaction, and non-linear behavior of members within seismic load paths, and was conducted for an earthquake event with a 500-year return period, only. The study only considered the lift span and then extrapolated the analytical results to the fixed spans.

The study identified the following seismic deficiencies in the structure for the 500-year event (it should be noted that ODOT and WSDOT desire a 500-year serviceability and a 1,000-year no-collapse performance criteria for a seismically retrofitted structure of this type and location):

- Bearings are inadequate (stability and shear at anchorages).
- Piles will have uplift forces, yet very limited uplift capacity exists between the pile cap and piles.
- Piles are overloaded in shear.
- Piles were not checked for bending, but are likely overloaded.
- Piers have steel reinforcing ratios below current code requirements (where pier reinforcement data is available).
- Piers do not have ductile details (confinement steel), required for inelastic performance expected in a 1,000-year event.
- Piers have marginal shear capacity for a 500-year event.
- The infill pier walls have little reinforcement and the connections between the piers and wall are inadequate for structural coupling between the bridge piers.
- Lift span tower members are overstressed.

Overloaded truss members include buckling for nearly all “X” bracing members, buckling of lateral cross frames and portal cross frames, inelastic behavior of bottom lateral diagonals, and bending/buckling of truss vertical members.

Based on a traditional retrofit approach, the DGES, Inc. report provides an estimated seismic retrofit cost of \$47 million for the foundations and \$6.3 million for bearings (an isolation system was suggested as part of seismic retrofit strategy, but no analysis of this approach was carried out). The estimates did not include cost for retrofitting the piers, substructure, or lift span mechanical and electrical systems. These cost estimates did not include soft costs such as project administration, design, traffic control, or construction inspection. The estimates were based on 1995 unit costs. Liquefaction (which is now known to be the most significant concern for these structures) was not considered in the retrofit strategy for the foundation retrofit.

The analyses did not include modification of the seismic forces to represent non-linear behavior of members, fusing of bearings, etc. As a result, the forces and displacements determined in the study, while indicative of general behavior and deficiencies, are gross estimates.

Other areas of potential vulnerabilities include: expansion joint performance, buckling of gusset plates, inadequate force transfer between gusset plates and members, strong member/weak connection issues, and lack of diaphragm action of the concrete deck.

Recent Liquefaction Study

Preliminary geotechnical investigations conducted by WSDOT in-house geotechnical staff in August 2006 (that are not part of the DGES, Inc. report) indicate that the site will likely experience liquefaction during a 500-year seismic event (to depths of about 50 feet, and to depths of about 60 feet under the 1,000-year event). The potential for loss of lateral support from such liquefaction will require that major retrofit work be performed on the foundation system (likely a complete supplemental system) should the structure retrofit proceed. This is discussed in detail later in this report.

This page intentionally left blank.

3. Seismic Retrofit Criteria

Foremost in determining the vulnerability and appropriate retrofit measures for any structure is a determination of the appropriate seismic loadings and levels of performance to be expected. For major structures throughout the U.S. and including the retrofit program for the California Toll Bridges, it is common practice to specify dual level earthquake and performance levels (i.e., Serviceability and No-Collapse.)

A Serviceability level can be defined in several ways:

- Require that damage is limited to that which will still allow the structure to function as an evacuation route and an emergency access route for reconstruction.
- Limit damage to only occurring on “secondary” members – those elements that will not impact use of the structure significantly and that can be inspected and repaired in a very brief period (i.e., 24 to 48 hours) or under traffic.
- Prohibit damage entirely by keeping the structural responses within the elastic range for the prescribed seismic event.

Defining the required level of service is important to determining the level of seismic retrofit since it will have a direct relationship to the types and extent of the retrofit. For example, in the case of piers which must remain serviceable and free of major repair following a design earthquake, the allowable strain in the pier reinforcement and concrete must be limited to prohibit permanent damage. Higher levels of allowable damage (and hence higher levels of repair following the design earthquake) will result in a “lesser” level of retrofit, or even a different approach to retrofitting.

A retrofit strategy that only results in a “no-collapse” level of performance can permit significant damage as long as collapse is prevented and there are no types of damage which could pose a threat to public safety.

In addition to the levels of performance, the Seismic Design Criteria must also define the level of design earthquakes to be considered, typically in terms of return period. This is commonly referred to as the Seismic Hazard. Two dominant sources contribute to the seismic hazard along the Bridge Influence Area:

- Portland Hills Fault (PHF) Zone (along the base of the West Hills).

The PHF is 6 km from the bridge site. The Maximum Credible Earthquake (MCE) on this fault is M 6.8. This event can result in peak ground (rock) accelerations (PGA) of 0.4 g to 0.7 g.

- Cascadia Subduction Zone (CSZ) off the Pacific Coast.

The CSZ is 100 km from the bridge site (along the coast). The MCE on this fault is M 9.0. Because of the distance from the site and the subsequent attenuation of the ground motions, the PGA is only 0.1 to 0.2 g. However, because of the type of fault (subduction zone),

more than one (1) minute of strong motion shaking can be expected and the resulting liquefaction potential may be roughly equivalent to that caused by the closer PHF.

No active faults are known to traverse the Bridge Influence Area. The United States Geologic Survey (USGS) 2002 PSHA reveals the following rock PGAs for the Bridge Influence Area:

- 0.42 g for 2,500-year recurrence.
- 0.27 g for 1,000-year recurrence.
- 0.19 g for 500-year recurrence.

No additional sources are expected to be added to the next iteration of USGS maps that would affect the seismic hazard along the Bridge Influence Area. It is unclear how the attenuation model changes in the next generation of USGS maps, and how it will affect the hazard along the Bridge Influence Area.

3.1 Study Events – Return Periods

Based on the input of ODOT and WSDOT State Bridge Engineers and with concurrence of the Panel, three sets of earthquake loading-performance goals were considered in evaluation of potential retrofit scenarios. These corresponded to the following return periods and service levels:

1. 100-year serviceability with 500-year non-collapse performance criterion.
2. 500-year serviceability with 1,000-year non-collapse performance criterion.
3. 500-year serviceability with 2,500-year non-collapse performance criterion.

For the CRC project alternatives that use the existing structures for arterial, pedestrian and bicycle, or transit (i.e., the Supplemental alternatives with Agency oversight), the 500-year serviceability with 1,000-year no-collapse performance criterion was selected since it is consistent with the criteria for other retrofitted structures in Oregon and Washington.

For Alternative 3, ODOT and WSDOT State Bridge Engineers stated that the 500-year serviceability with 1,000-year non-collapse performance criterion would also be appropriate since it is consistent with existing seismic retrofit criteria, even though construction of a new or supplemental bridge would require the application of the 2,500-year event, which was selected by the Agencies for the “No Collapse” service level for the new structures. The Panel does not concur with this approach for defining the Design Criteria for Alternative 3 because they view it as not consistent with the level of performance for the new structures.

The 100-year serviceability with 500-year non-collapse performance criterion was reserved as lower bound criteria for use only if the cost of retrofit to the 1,000-year event was excessive. However, based on the Panel study, the difference between the 500-year no-collapse and 1,000-year no-collapse criteria was estimated not to be excessive. Even though the 500-year no-collapse is used in Washington as a retrofit criterion for typical bridges, the importance and critical nature of this crossing was found to justify the higher 1,000-year criteria.

4. Approach to Evaluation

In evaluating the retrofit options, the Panel considered the previous (though limited) seismic evaluation conducted in 1995, the eras in which the structures were designed and constructed, past similar vulnerability and retrofit studies of other major river crossing structures, and most importantly, the liquefaction analysis results recently completed by WSDOT.

Based on the results of the liquefaction analysis and the expected levels of shaking for the design events, one must assume that the subsequent loss of lateral (and possibly also vertical) foundation support associated with liquefaction at the depths noted will result in overall instability of the structures. For this reason, the Panel considered full retrofit of the foundations and a commensurate retrofit of the piers to provide the strength and ductility required for the target performance.

In order to achieve serviceability in the superstructure and bearings, these elements were also considered for retrofit. Retrofit strategies and techniques that were successful on other similar projects were considered as likely options for the retrofits on the Interstate Bridges.

4.1 Conceptual Retrofit

Foundation and Pier Retrofit: The foundations will comprise the largest element and cost of the retrofit. Two alternatives were considered: one that retrofits the foundations at the pile cap level and below and one that constructs a new pile cap at or above the water level. For costing purposes, both options assumed pile groups that consist of large (8 feet to 12 feet) diameter shafts around each pier, and that the piles would be up to 200 feet long, reaching far below the liquefaction layers and to or nearly to the Troutdale formation (rock).

Having the new pile cap at or above the water level could eliminate the need for cofferdams. The lower range of values reflects this alternative. The higher-end costs include a cofferdam and work below the water line.

For the retrofit of the piers, primarily to provide additional ductility, the concept assumes that #8 welded hoops are placed at 6-inch spacing along the entire face of the pier. This includes drilling through the in-fill walls between the columns and running the hoops through the drilled holes. The entire pier would then be encased in a shotcrete jacket either 6 inches or 12 inches thick. These concepts are shown in Figures 4-1 and 4-2.

Figure 4-1. Foundation and Pier Retrofit Alternative 1

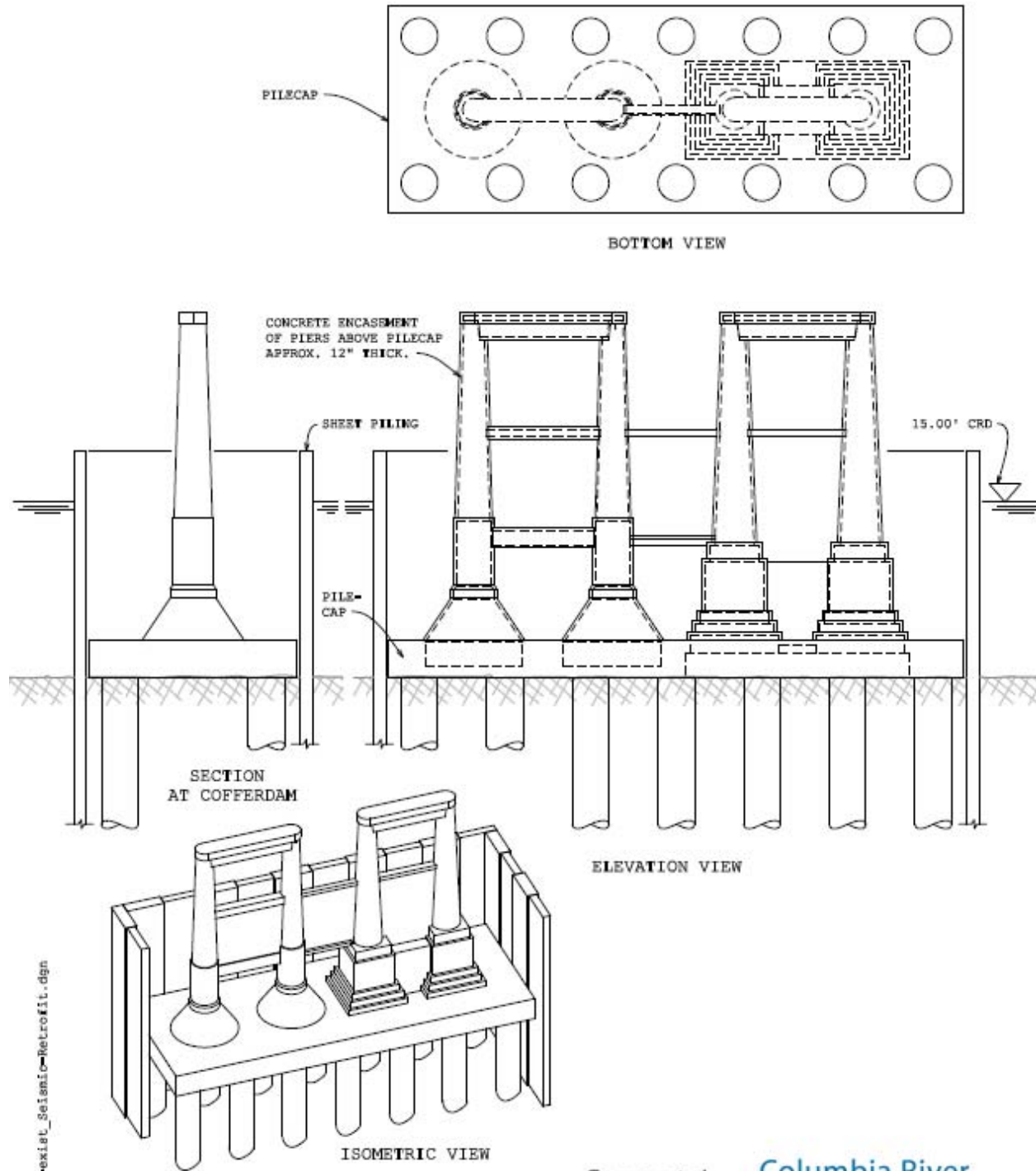

CRC-exist_SeismicRetrofit.dgn
1:40
10/12/2006

Concept 1
Existing Structure Seismic Retrofit



Figure 4-2. Foundation and Pier Retrofit Alternative 2

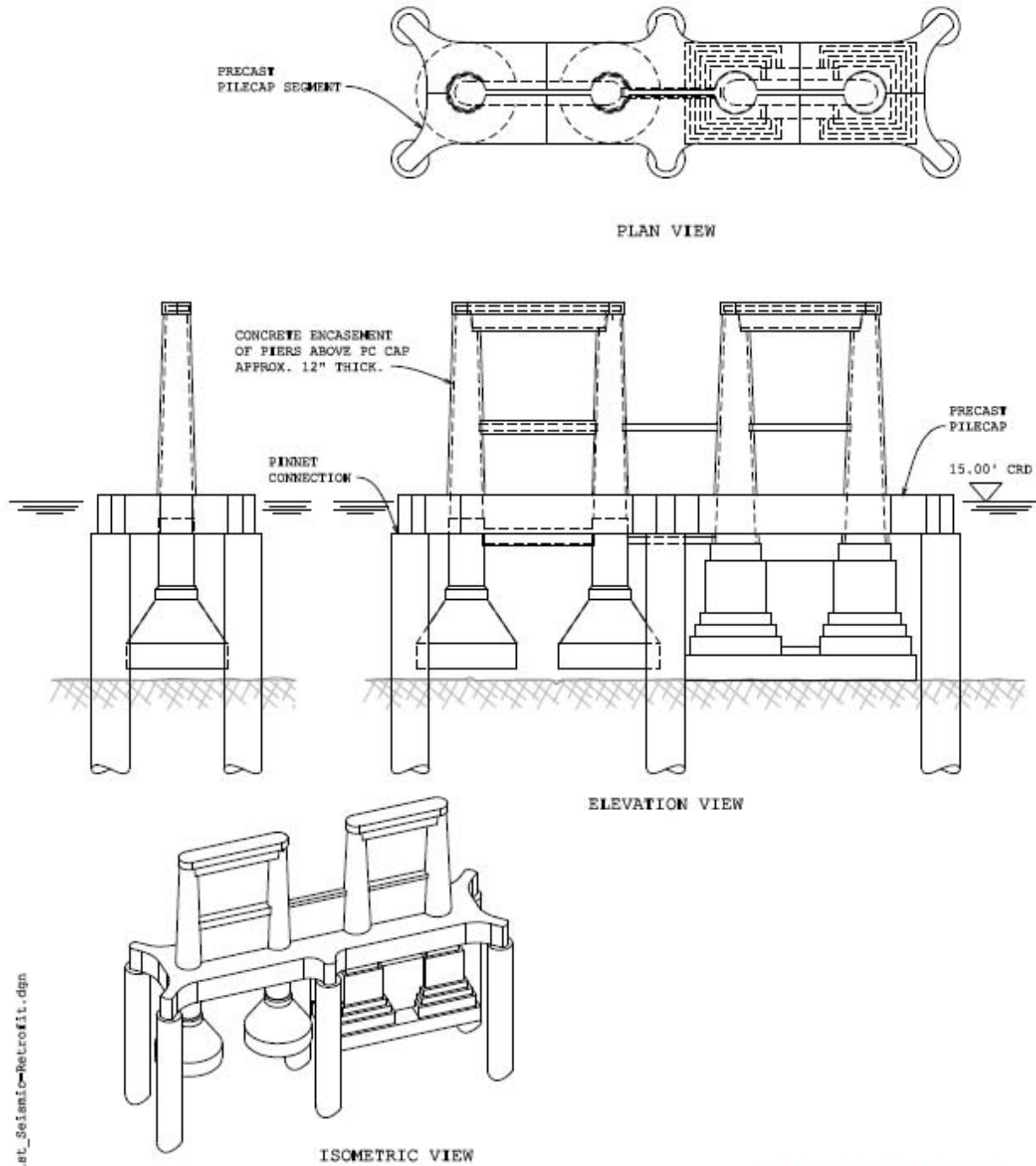

CSC-exist_Seismic-Retrofit.dgn

1:40
10/12/2006

Concept 2
Existing Structure Seismic Retrofit



Bearings

Bearings are assumed to be replaced or retrofitted for strength. The cost opinions reflect both of these alternatives. No relevant data was available to the Panel to determine optimum bearing types and/or sizes.

Vertical catcher/jacking blocks were assumed to be added at all piers, as were lateral and longitudinal restrainer assemblies.

Superstructure

A minimum level of member replacement and retrofit was assumed to be required to provide for a superstructure that would not experience damage. A weight of additional superstructure steel was estimated at 10 pounds per square foot of deck based primarily on the retrofits of major steel truss bridges in California; namely, the I-80 Carquinez, I-580 Richmond-San Rafael, and I-680 Benicia Martinez toll bridges.

The Lift Span Towers were assumed to be replaced in parts and phases, as there are several deficiencies related to the up position of the counterweights and/or the lift spans. The costs of mechanical and electrical modifications or upgrades were not considered.

5. Cost Opinions

A range of cost opinions is provided below for the concept retrofit for each element. The range of costs was determined by very rough approximations using element sizes and costs from previous retrofits and experience and has been escalated (roughly) to 2006 dollars.

Seismic Design Criteria		Performance Level			
		Cost Range – Serviceable		Cost Range – No-Collapse	
		Low	High	Low	High
100y – Serviceability & 500y – No-Collapse	Foundation	\$50	\$100	\$50	\$100
	Pier	\$10	\$30	\$10	\$30
	Bearing	\$6	\$6	\$6	\$6
	Superstructure	\$22	\$31	\$22	\$31
Subtotal		\$88	\$167	\$88	\$167
500y – Serviceability & 1,000y – No-Collapse	Foundation	\$55	\$105	\$55	\$105
	Pier	\$10	\$30	\$10	\$30
	Bearing	\$9	\$9	\$9	\$9
	Superstructure	\$26	\$36	\$26	\$36
Subtotal		\$100	\$180	\$100	\$180
500y – Serviceability & 2,500y – No-Collapse	Foundation	\$60	\$110	\$60	\$110
	Pier	\$10	\$30	\$10	\$30
	Bearing	\$13	\$13	\$13	\$13
	Superstructure	\$29	\$40	\$29	\$40
Subtotal		\$112	\$193	\$112	\$193

(Note: Values are in million dollars)

Lifecycle costs were not considered explicitly by the Panel, though in determining the real cost of keeping the existing structures, a complete LC cost analysis would be prudent.

Qualifiers

Due to the limited available data and seismic analyses as well as the short duration of the workshop, the Panel makes no guarantees as to the accuracy of the raw construction cost estimates/opinions provided. Only raw bridge construction costs were considered, which do not include soft costs such as project administration, design, traffic control, or construction inspection. Values shown are in 2006 dollars.

This page intentionally left blank.

6. Next Steps

The panel identified the following steps which are recommended to determine a more reliable understanding of the vulnerabilities and potential retrofits and construction cost estimate, which would be necessary as part of the DEIS should the alternatives that include keeping the existing structures move into the DEIS phase.

- Simple push-over analysis can be conducted to get a better idea of the seismic load paths, deficiencies, and rehabilitation that would be required at the foundations/piers.
- Compare similar projects (e.g., California toll bridges) and the DGES, Inc. reports to calibrate and adjust for this site and to determine the superstructure and bearing retrofits.
- Perform preliminary design verification of retrofit schemes for foundation and pier elements.
- Estimate the bearing replacement size and reconstruction requirements.
- Compare lbs/sf cost for steel retrofit based on California toll bridges.
- Perform quantity takeoff for cost estimates, given the cases in the table above, and expand for each bridge.
- Review the bid tabs from similar projects (e.g., California toll bridges) to use as a cross check for reasonability of the estimates derived above.
- Complete the ongoing geotechnical study to validate the preliminary findings presented in this report.
- Prepare a tech memo (or report) summarizing the tasks above.

6.1 Other issues for consideration

Impact of pier modifications on navigation channel:

Significant retrofit to the existing piers could impact the available width of the navigation channels.

Aesthetics and importance of maintaining historical perspective:

Similar structures with historic significance have been retrofitted, both in the superstructure and substructure, to comply with the requirements for preservation of historic structures. If approached with care and consideration of these requirements, the retrofit can be accomplished without severe (though still “significant”) impacts to the historic character of the structures.

This page intentionally left blank.

7. Summary

The primary hazard posed to the bridge is liquefaction of the supporting soils during a seismic event. A seismic retrofit of the existing I-5 Interstate Bridges is not only feasible, but is also recommended for any future use of the bridges. Retrofit strategies can be developed which would have minimal effect on the appearance of the bridge. A conceptual cost opinion of \$88 million to \$190 million for raw construction was determined by the Panel, based upon three different seismic hazards and two levels of performance. Although further analysis and refinement of a retrofit scheme and associated cost are needed to get an accurate number, decision makers can use the cost estimates given in Section 5 to gain an appreciation for the magnitude of cost associated with seismic retrofitting of the bridges to different levels of performance.

Further documentation of the workshop proceedings is included in Appendices A, B, and C following.

This page intentionally left blank.

Appendix A – Meeting Summary

MEETING: Seismic Vulnerabilities Study Panel

MEETING DATE: August 28 – 29, 2006

ATTENDEES:	Panel Members	Mark Hirota (Chair) PB, Jugesh Kapur and Bill Hegge- WSDOT, Bruce Johnson and Jan Six-ODOT, Tim Rogers- FHWA, Steve Thoman- DEA, Frieder Seible- UCSD, Tom Cooper, Farid Nobari and Joe Wang-PB
	Guests	Kris Strickler, Lynn Rust, Frank Green- WSDOT, Jay Lyman and Ron Anderson -DEA, John Horne and Matt Deml-PB

FROM: Matt Deml

The following is a meeting summary which includes meeting minutes and subsequent comments expressed by panel members.

Purpose of the Study Panel

The disposition of the existing bridges is unknown at this time.

The purpose of this panel is to consider and respond as well as reasonably possible within the limited time the following questions

- Is it feasible to retrofit the existing structures for seismic loads? If so, how?
- How would retrofit affect the existing structure with regard to 4(f) sensitivities?
- What are the costs associated with retrofitting the structures?
- Within the context of the Environmental process currently being undertaken, what additional steps should be taken to properly address the issue of seismic retrofit of the existing I-5 Interstate Bridges?

Background of the Structures

The Northbound bridge was built in 1917, originally with a flat grade. It was the first crossing of the Columbia River.

The Southbound bridge was built in 1958. At the same time, the 1917 structure was retrofitted to provide a better opening for river traffic. This included replacing two short spans with one long span and modifying piers and bearings to match the profile of the newer structure, increasing the vertical clearance.

Bridges consist of steel through truss superstructures, rocker bearings, concrete piers, timber piles, and lift spans.

Little to no information is known about the foundation and pier construction of the 1917 bridge.

- There is little or no pile information is available regarding the pile capacity and pile tip elevations
- There is little or no data exists on reinforcement in the piers

Some investigation of the existing footings/scour holes has been done.

- Investigations show that footings (underwater) have 3' – 27' of exposure.
- No undermining of the footings was observed.
- No piles are exposed.

Previous Seismic Study

In 1995, ODOT commissioned David Goodyear Engineering Services, Inc (DGES). to study the seismic performance of the bridges on a limited scope and budget agreement.

The study did not take into account liquefaction, soil structure interaction, non-linear behavior of members and system, and was conducted for a 500-year spectra. The study only considered the lift span and then extrapolated the analytical results to the fixed spans.

The following deficiencies were found for a in this study for a 500-year event:

- Bearings are inadequate (stability of the high profile bearings, and shear strength of the anchorages)
- Piles will have uplift forces, yet no uplift capacity between the pile cap and piles. (Note that the pile embedment through the concrete seal will result in potential of rocking of the footing on top of the seal).
- Piles are overloaded in shear.
- Piles were not checked for bending, but are likely overloaded.
- Piers have steel reinforcing ratios below current code requirements (where pier reinforcement data is available.)
- Piers do not have ductile details (confinement steel), required for inelastic performance in a 1000 year event.
- Piers have marginal shear capacity for a 500 year event.
- The infill pier walls have little reinforcement and the connections between the piers and wall are inadequate for structural coupling between bridge piers.
- Lift span towers are overstressed

Overloaded truss members include:

- Buckling for nearly all "X" bracing members,
- Buckling of lateral cross frames and portal cross frames,
- Inelastic behavior of bottom lateral diagonals, and
- Bending/buckling of truss vertical members.

An isolation system was suggested as part of seismic retrofit strategy.

The DGES reports estimated a seismic retrofit cost of \$47 million for the foundations and \$6.3 million for bearings.

The estimates did not include cost for retrofitting the piers, substructure or lift span mechanical and electrical systems. These cost estimates did not include soft costs such as project administration, design, traffic control, or construction inspection and support. The estimates were based on 1995 unit costs. Liquefaction was not considered in the foundation retrofit strategy.

The analyses the study used did not chase the seismic forces to logical conclusions (non-linear behavior of overloaded members, fusing of bearings, etc. were beyond the scope of work). The forces and displacements determined in the study, while indicative of behavior, are gross estimates.

Other areas of potential vulnerabilities include expansion joint performance, buckling of gusset plates, inadequate force transfer between gusset plates and members, strong member/weak connection issues, and lack of diaphragm action of the concrete deck.

Preliminary geotechnical investigations, conducted by the state agencies in August of 2006 (that are not part of the DGES Report), indicate that the site will experience liquefaction almost at a 100 year seismic event. Liquefaction potential will result in major work being performed on the foundation system, likely a complete supplement system. This is believed to be the most significant element of required seismic retrofit, for both structures, for any event larger than a 100 year event.

Seismic Hazard

Two dominant sources contribute to the seismic hazard along the Bride Influence Area (BIA):

- Portland Hills Fault Zone (along the base of the West Hills)
 - 6 km from the bridge site
 - MCE: M 6.8; 0.4 to 0.7g PGA
- Cascadia Subduction Zone
 - 90 km from the bridge site (along the coast)
 - MCE: M 9.0; 0.1 to 0.2g PGA; > 1 minute of strong shaking

No active faults are known to traverse the bridge influence area

USGS 2002 PSHA reveals the following rock PGA's for the BIA:

- 0.40 g for 2,500 year recurrence
- 0.27 g for 1,000 year recurrence
- 0.19 g for 500 year recurrence
- 0.13 g for 250 year recurrence

No additional sources are expected to be added to the next iteration of USGS maps that would affect the hazard along the BIA

It is unclear how the attenuation model changes in the next generation of USGS maps will affect the hazard along the BIA

Current State DOT Policies on Seismic Rehab

ODOT seismic retrofit policy

- Retrofit required for 0.19g or greater
- Phase I retrofit is common
- Phase II retrofit (foundation retrofits) is not common (it has been done on two bridges in the state)

WSDOT seismic retrofit policy

- Retrofit focuses on structures along the I-5 corridor and in the Puget Sound area
- Retrofit is being carried out in phases, began in 1991
 - Phase I – Superstructure retrofit (complete)
 - Phase II – Single column substructures (99% complete)

- Phase III – Multiple column substructures (currently underway)
- No foundation retrofit has been done
- Response Spectrum Analysis (RSA) with a 500-year return period is used for analysis.

Bridge Use Alternatives

Seven alternatives are being investigated in which the existing bridges would be used in some capacity. The panel considered the proposed uses and suggested an appropriate level of service that should be considered for each alternative.

- Alternatives 1 and 2 – No build
 - Structures remain in use as I-5 bridges
 - No seismic retrofit
 - Lifeline route – meet more stringent serviceability requirements
- Alternative 3
 - Structures remain in use as I-5 bridges
 - Lifeline route – meet more stringent serviceability requirements
- Alternative 4
 - SB structure to be used for LRT – meet less stringent serviceability requirements
 - NB structure to be used for arterial traffic – collapse prevention
- Alternatives 5 – 7
 - Structures to be used for arterial traffic – collapse prevention

Geotechnical Conditions (based on best available data to date)

No geotechnical data is available with regard to the 1917 structure. Very little data (rudimentary borehole stick logs) were collected for the 1958 structure.

Current investigation

- Geophysical investigation along the river shows a distinct contact between the alluvium and bedrock. The bedrock (Troutdale formation) is relatively shallow along the Washington shoreline, but is over 200 feet deep at Hayden Island.
- Four boreholes are being drilled along the existing bridge to provide positive confirmation of the Troutdale contact. Holes completed to date generally corroborate the contact revealed by the geophysical study.

Two soils dominate the site

- Troutdale rock formation
 - A conglomerate
 - Shear wave velocity of 2000 – 3000 ft/s base on DOGAMI study (rock like)
 - Driven steel piles are typically designed to develop their full structural capacity in this material
- Alluvial deposits

- Primarily fine sand; clean to silty; some gravel; loose grading to dense at depth
- Preliminary analyses indicate a high liquefaction potential for the 500 year event (up to 50' deep)
- Lateral spreading will be a potential problem especially at the river banks and near the scour holes
- Preliminary analyses indicate the anticipated settlement at the surface would be approximately 1.5' for the 1,000 or 2,500-year event, and 16" for the 500-year event.

Study events – return periods

Three levels of retrofit will be evaluated corresponding to the following return periods and service levels

- 100-year serviceability with 500-year non-collapse performance criterion
- 500-year serviceability with 1000-year non-collapse performance criterion
 - ODOT and WSDOT suggested this might be the preferred retrofit criterion for these bridges.
- 500-year serviceability with 2500-year non-collapse performance criterion
 - This performance level was considered for Alternative 3.

Vulnerabilities and Mitigation measures for bridge components

Foundation

- Generally, the substructure (including foundation, piers, bearings) costs are anticipated to run about 70% - 80% of the total structural retrofit cost

Vulnerabilities

- Liquefaction during a seismic event poses the greatest threat to the bridge's structural systems.
- Existing foundations have too many unknowns associated with their behavior and performance. A seismic retrofit scheme would assume the existing foundations only take the dead load and all group VII (seismic group) loadings would be taken by a new foundation system.

Mitigation

- Option A – additional piling
 - Cofferdam may be required with environmental constraints
 - Drilled shafts with steel casings
- Option B – soil remediation
 - Injection grouting is the most likely solution
 - This has numerous environmental and constructability constraints
 - Vibration around the existing foundations could cause liquefaction if supplemental piles were driven.
 - Too many unknowns about the foundations of the existing structures and injection grouting for this application suggests that soil remediation may not be a viable option

Piers

- Fenders may be required adjacent to the lift span if the piers sizes are increased

Vulnerabilities

- Existing main reinforcement ratio is less than 1%
- Insufficient concrete confinement exists per current seismic design standards.
- Unknown or inadequate reinforcement details

Mitigation

- Confine concrete columns and piers with steel plate, carbon fiber, or reinforced concrete.

Bearings

Vulnerabilities

- Existing high-profile bearings would potentially fail if large displacements occur because of loss of stability due to liquefaction. Unseating of the spans is possible.

Mitigation

- Option A – Replace bearings with isolation bearings
 - Add restrainer assemblies, connecting the superstructure to the piers with a secondary system.
 - Isolation cannot be used for the lift spans since the lift spans and counterweights are locked within the tower assembly. As a result, the entire tower, counterweight, bearings, and lift span have to be strengthened.
- Option B – Retrofit existing bearings
 - Add catcher block and restrainer assemblies

Superstructure

Vulnerabilities

- The counterweights are unrestrained and the towers are structurally inadequate
- Many truss members are overstressed and may need replacement
- Many truss connections have stability issues and may need to be strengthened or replaced.
- Rivets in the old structure are likely to be weak and may need replacement.

Mitigation

- Complete replacement of towers is a possibility.
- Member replacement will need to be determined on a member-by-member basis.
- Deck connection to the floor beams will need to be investigated. A composite deck is preferable to ensure adequate load transfer.
- Gussset plate replacement
- Increasing connection strength compare to member strength
- Bolt replacement
- Addition stiffeners to truss members and gussset plates

Possible Rehabilitation Scheme and Cost Opinions

One possible rehabilitation scheme was developed and some cost opinions were derived based on this scheme. The assumptions used were as follows:

- Foundation assumptions
 - Six 10' diameter drilled reinforced concrete piles (with the casings left in place) per pier (up to 200' long).
 - Pile cap could tie into the pier at or below the water level.
 - Tie-in at the water level could eliminate the need for a cofferdam (See Concept 2). The low-end costs in Table 1 reflect this.
 - The higher costs account for a tie in below water level at the existing pile caps and hence a cofferdam (See Concept 1).
- Pier Jacketing assumptions
 - #8 welded hoops @ 6", drilled through the in-fill walls.
 - 6" shotcrete jacket
- Bearing assumptions
 - Rehabilitate or replace existing bearings
 - Add vertical catcher/jacking blocks
 - Add lateral and longitudinal restrainer assemblies
- Superstructure assumptions
 - Towers to be completely replaced
 - Costs of mechanical and electrical modifications or upgrades are not considered.
 - Structural steel replacement is assumed to be 10 lb/ft² of plan area of deck.
- Other cost opinion assumptions
 - The follow cost opinions are based on contractor bid prices only. They do not include design, management, mobilization, contingency, traffic control, roadway surface improvements, construction inspection, etc...
 - Costs do not reflect analysis. They are based on costs from similar projects.
 - All costs presented are in 2006 dollars.
 - No life cycle costs have been analyzed to taken into account.

Table 1 – Construction Cost Opinions (millions) for Both the 1917 and 1958 Bridges)

		Serviceable		No Collapse	
		Low	High	Low	High
100y - Serv. 500y – Col.	Foundation	50	100	50	100
	Pier	10	30	10	30
	Bearing	6	6	6	6
	Superstructure	22	31	22	31
Subtotal		88	167	88	167
500y – Serv. 1000y – Col.	Foundation	55	105	55	105
	Pier	10	30	10	30
	Bearing	9	9	9	9
	Superstructure	26	36	26	36
Subtotal		100	180	100	180
500y – Serv. 2500y – Col.	Foundation	60	110	60	110
	Pier	10	30	10	30
	Bearing	13	13	13	13
	Superstructure	29	40	29	40
Subtotal		112	193	112	193

General Observations

The construction duration of the retrofit would likely be 3 – 4 years

The 1958 (SB) structure would likely cost less to retrofit than the 1917 (NB) structure.

Key Findings

It is possible to retrofit the existing structures. The levels of seismicity are relatively low compared to other regions on the West Coast where retrofit of major bridges has been undertaken.

Based on the conceptual retrofit strategy developed by the Panel, the anticipated raw construction costs, in 2006 dollars, range from \$88 Million to \$193 Million. For discussion, these can be rounded to \$100 million to \$200 Million.

Liquefaction potential exists to significant depths (based on August 2006 data). This poses the largest potential source of vulnerability to the structures.

A two-level seismic design criteria should be adopted (Serviceability, and Collapse Prevention)

The following areas of the existing structures are potentially vulnerable

- Foundation
- Piers
- Bearings
- Superstructure

Next Steps

The Panel recommends that the following steps be taken if a more accurate cost is deemed necessary. These suggested steps are short of a typical Vulnerability Study for a major bridge seismic retrofit, but would provide results that are more reliable than the conceptual retrofit strategy developed by the panel.

- Perform the following tasks to better understand the cost and issues associated with retrofitting the bridges for earthquake hazards
 - Simple push analysis to get a better idea of the rehabilitation that would be required at the foundations/piers. This analysis would assess, in gross terms, the performance and loads that could be expected from a seismic event.
 - Look at similar projects (California toll bridges and other projects in the U.S.).
 - Consider data regarding the superstructure and bearings from the 1995 DGES reports, noting the abbreviated analytical methods.
 - Perform preliminary design of retrofit schemes for foundation and pier elements.
 - Estimate the bearing replacement size and reconstruction requirements.
 - Use lbs/sf cost for steel retrofit based on (California toll bridges).
 - Perform quantity takeoff for cost estimates given the cases in the table above (and expand for each bridge).
 - Review the bid tabs from similar projects (California toll bridges) to use as a cross check for reasonability of the estimates derived above.
 - Prepare a tech memo (or report) summarizing the tasks above.
- The ongoing geotechnical study should be completed to validate the preliminary findings presented in this report.

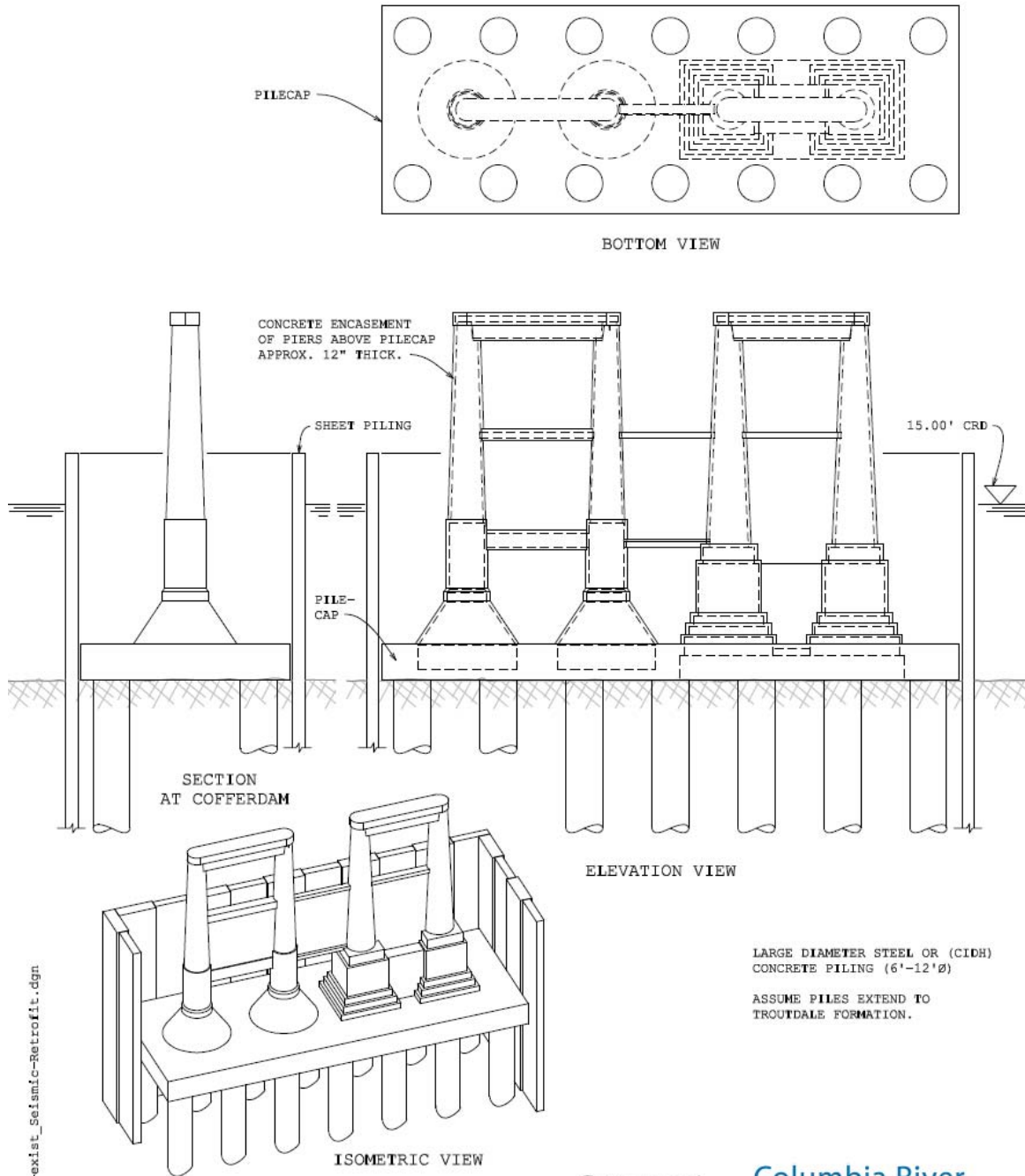

CRC-exist_Seismic-Retrofit.dgn

1:40
9/18/2006

Concept 1 Existing Structure Seismic Retrofit



LARGE DIAMETER STEEL OR (CIDH)
CONCRETE PILING (6'-12'Ø)
ASSUME PILES EXTEND TO
TROUTDALE FORMATION.

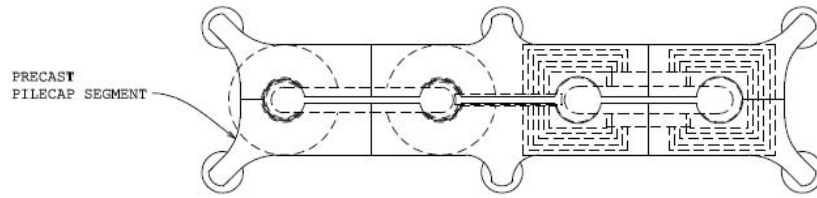

PLAN VIEW

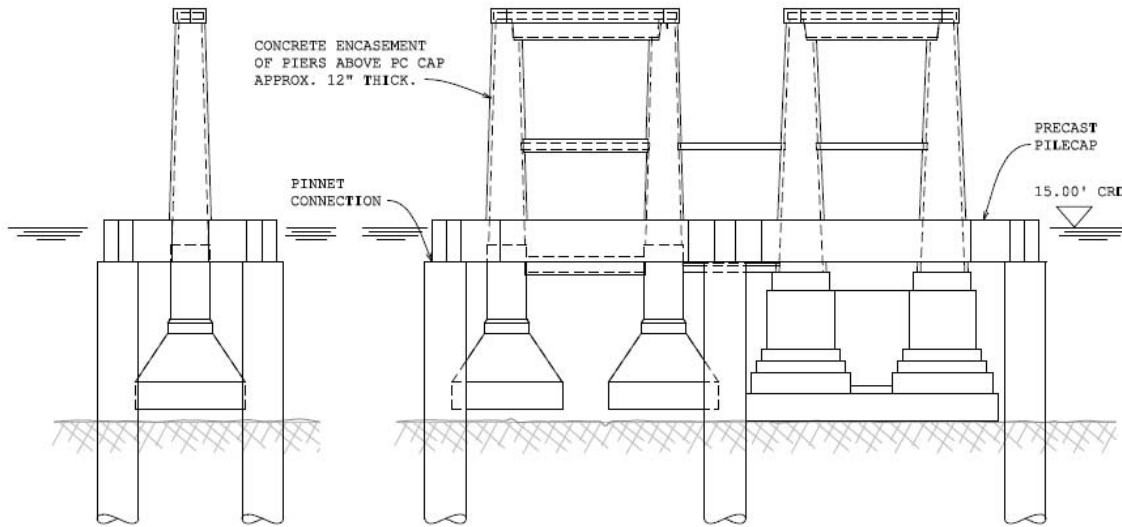

ELEVATION VIEW

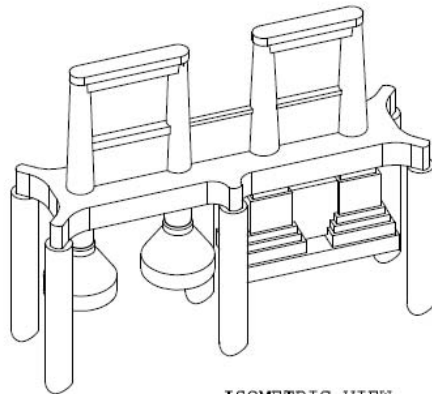

ISOMETRIC VIEW

LARGE DIAMETER STEEL OR (CIDH)
CONCRETE PILING (8'-12'Ø)
ASSUME PILES EXTEND TO
TROUTDALE FORMATION.

CRC-exist_Seismic-Retrofit.dgn

1:40
9/18/2006

Concept 2
Existing Structure Seismic Retrofit



Appendix B – Seismic Panel Presentation, August 29, 2006

Columbia River **CROSSING**

Seismic Panel Presentation

August 28 - 29, 2006

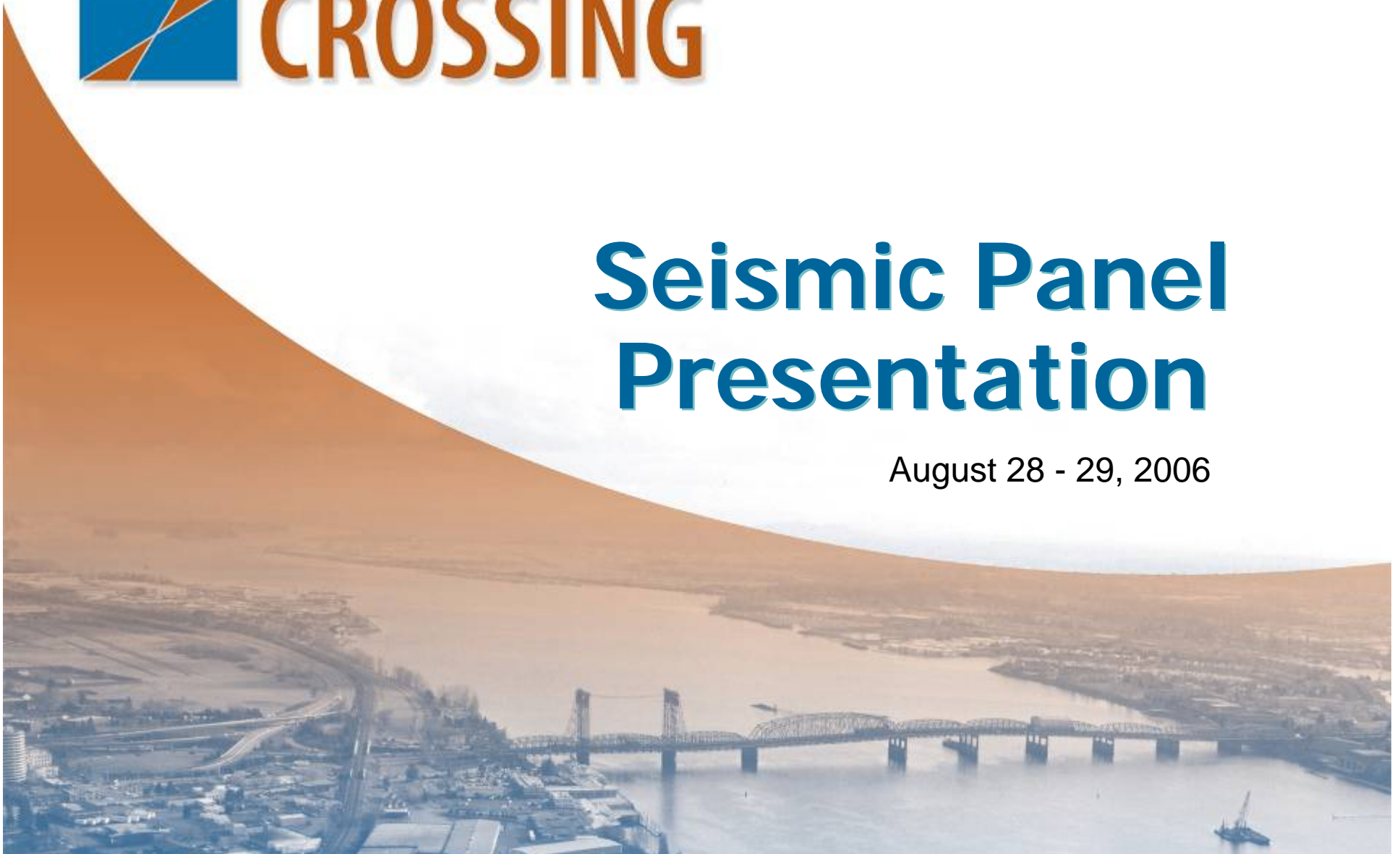

Seismic Panel Key Findings

- Liquefaction to significant depths
- 2 level seismic design criteria
- No Collapse Retrofit – Minimum Required
- Cost Opinions
- Vulnerable Elements / Seismic Strategies
 - Foundations
 - Piers
 - Bearings
 - Superstructure



Seismic Panel Cost Summary



		Serviceable		No Collapse	
		Low	High	Low	High
100y - 500y	Foundation	50	100	50	100
	Pier	10	30	10	30
	Bearing	6	6	6	6
	Superstructure	22	31	22	31
		88	167	88	167

500y - 1000y	Foundation	55	105	55	105
	Pier	10	30	10	30
	Bearing	9	9	9	9
	Superstructure	26	36	26	36
		100	180	100	180

500y - 2500y	Foundation	60	110	60	110
	Pier	10	30	10	30
	Bearing	13	13	13	13
	Superstructure	29	40	29	40
		112	193	112	193

Foundation - Add Large Dia Steel Caissons / Reinforced Concrete

Pier - Column Jacket + Wall Reinf

Bearing - Ret Bearing / Isolate

Superstructure - Connection & Member Strength @ Piers and Tower / or Isolation System

Key Structural Elements

- Foundations
- Piers
- Bearings
- Superstructure



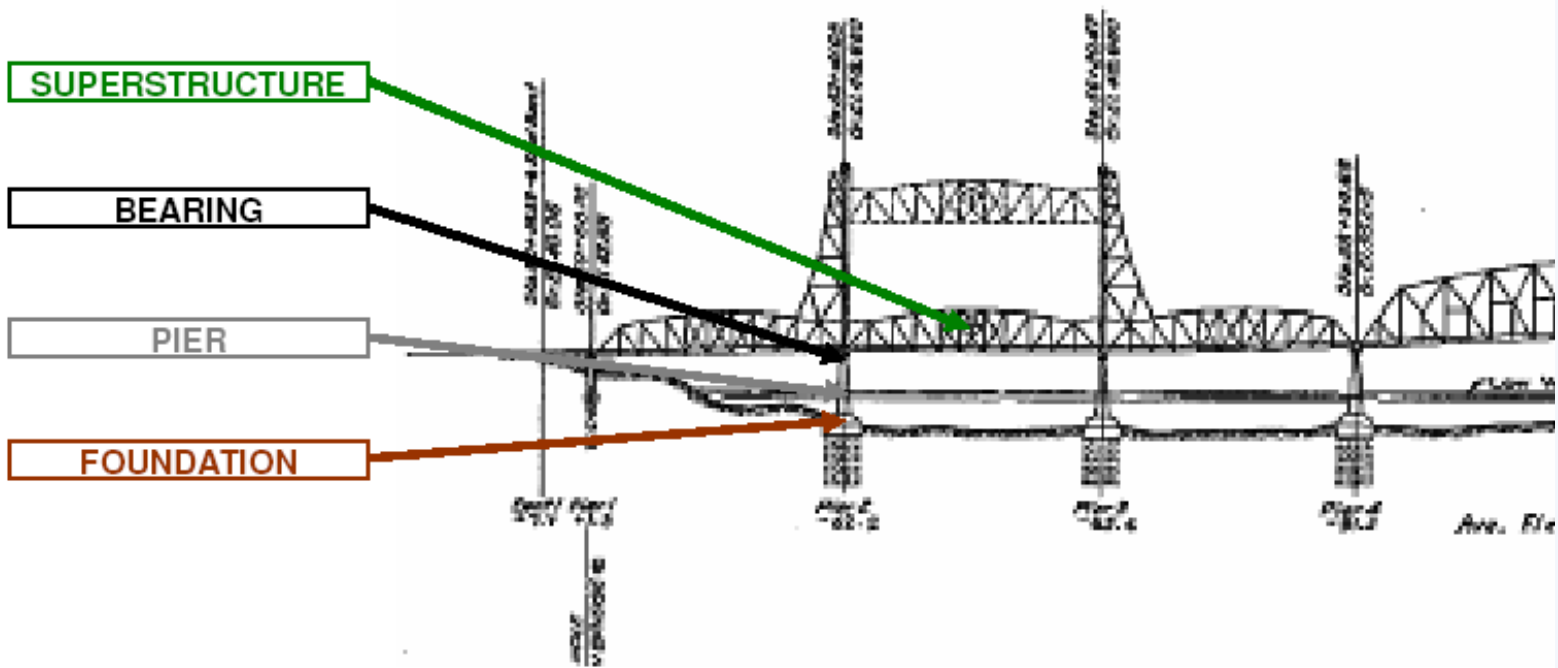

Key Structural Elements

- **Foundations (50 – 110)**
- Piers
- Bearings
- Superstructure



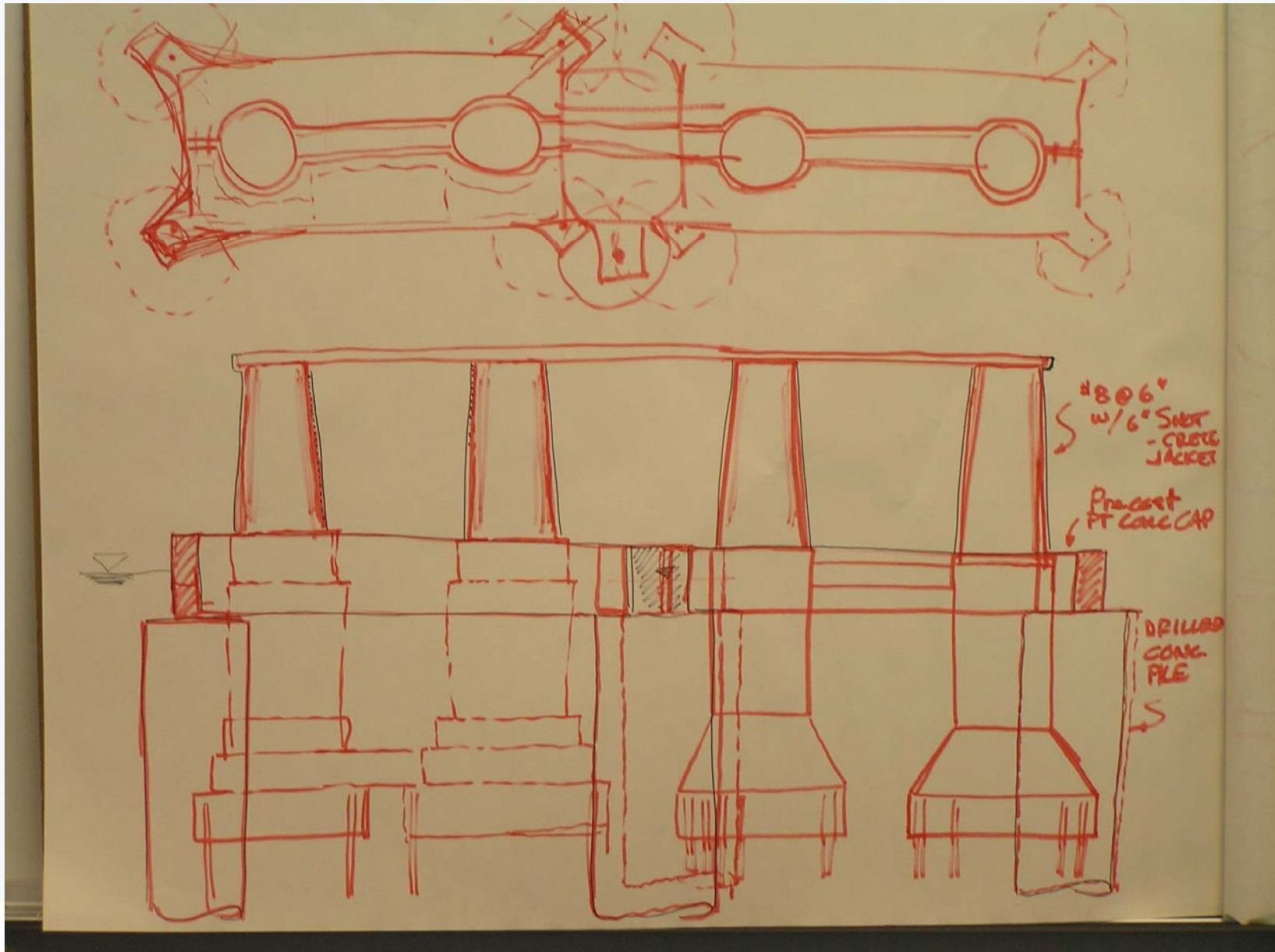

Key Structural Elements

- Foundations
- **Piers (10 – 30)**
- Bearings
- Superstructure



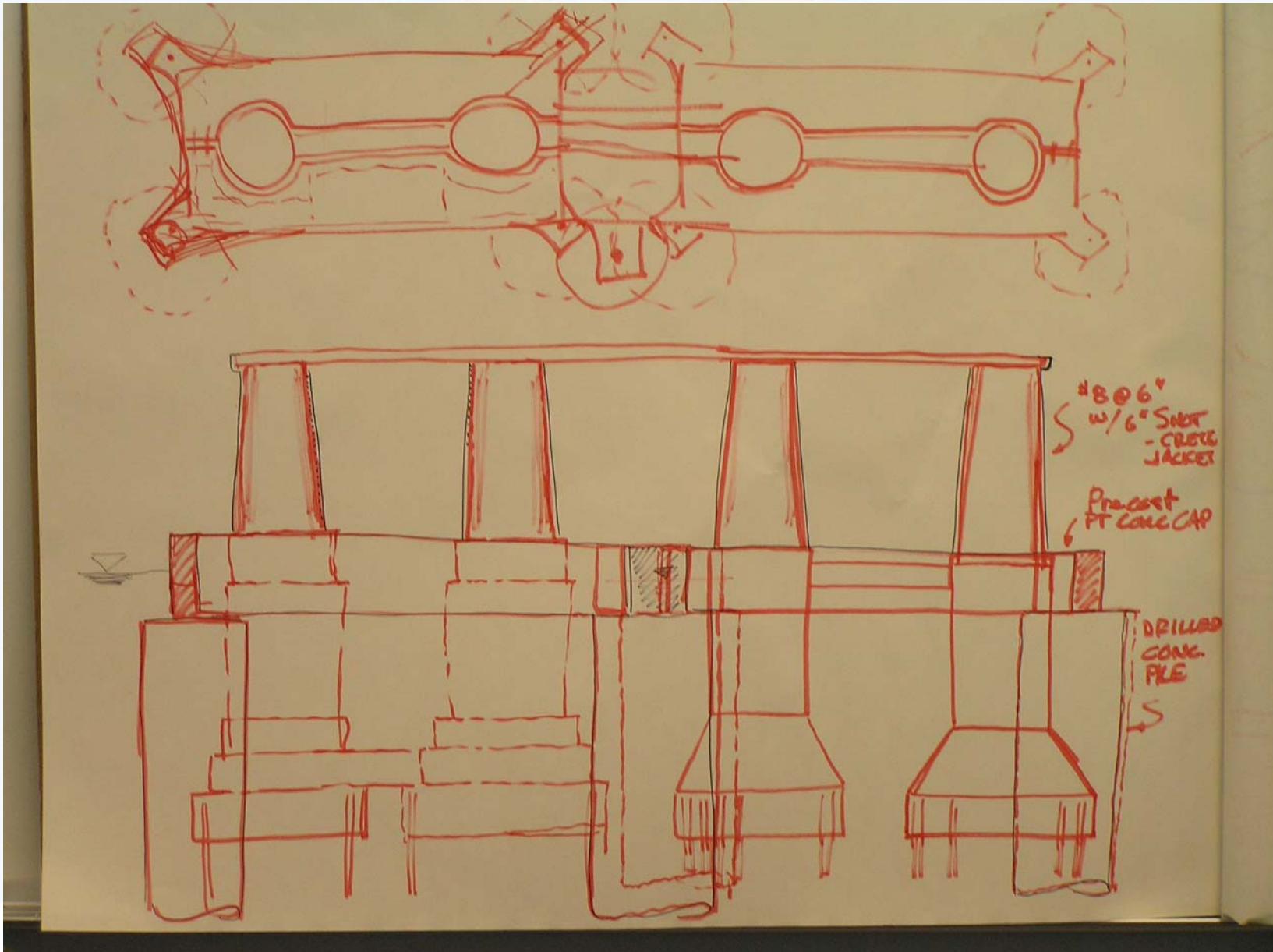

Key Structural Elements

- Foundations
- Piers
- **Bearings (6 – 13)**
- Superstructure



Bearings Repair/Retrofit/Replacement

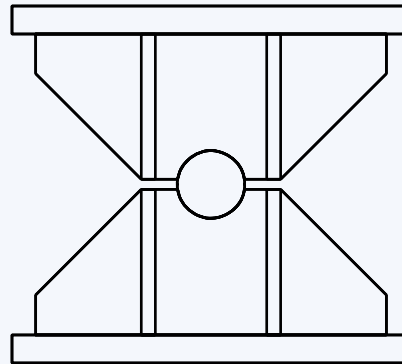

\$14 to \$20 million Range
(Based on CA toll Retrofit data)

Lateral Stiffening of High-Profile Rocker Bearings

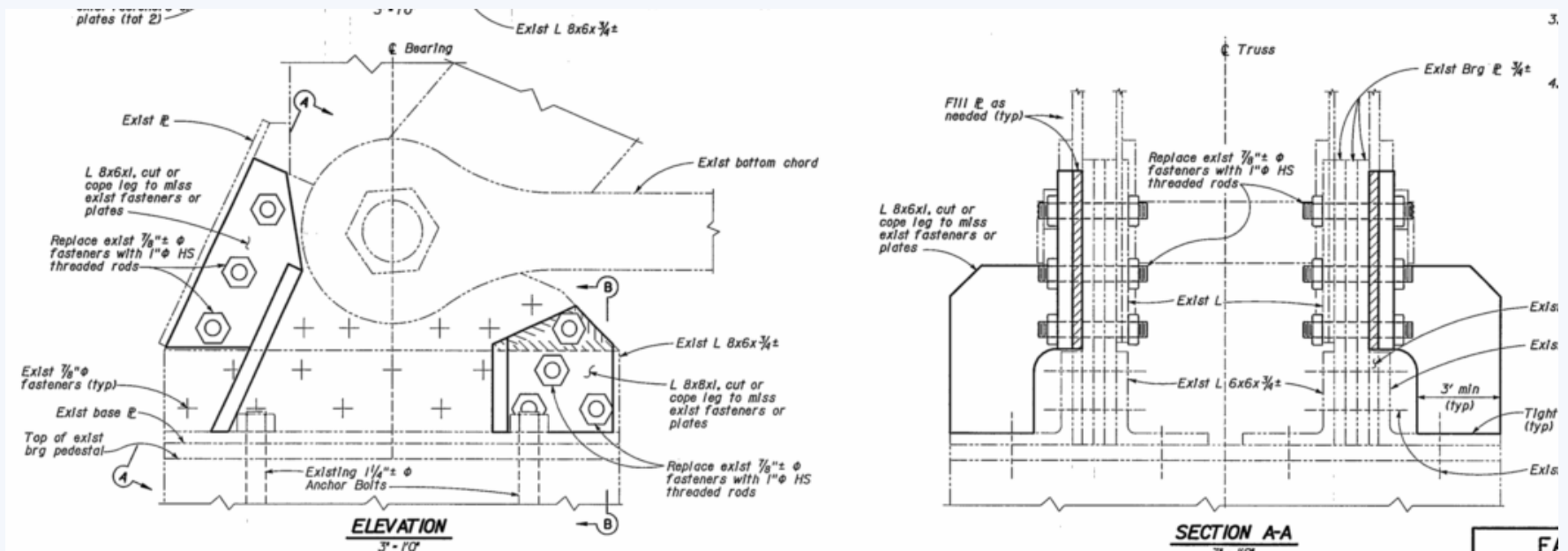

\$20000 Each Typical locations

Excluding 8 Custom replacement for Lift Span Bearings

Isolation Bearings

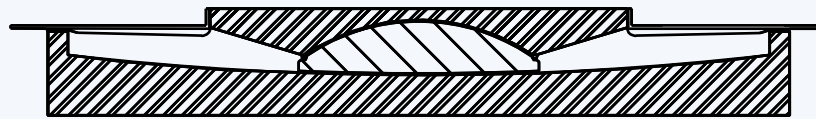
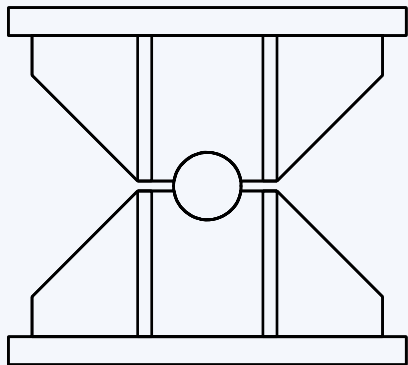

\$75000 + \$15000

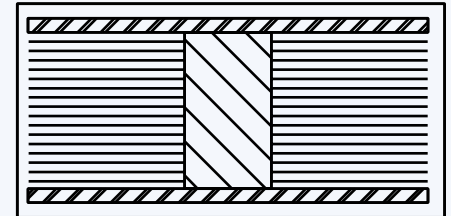

\$25000 + \$15000

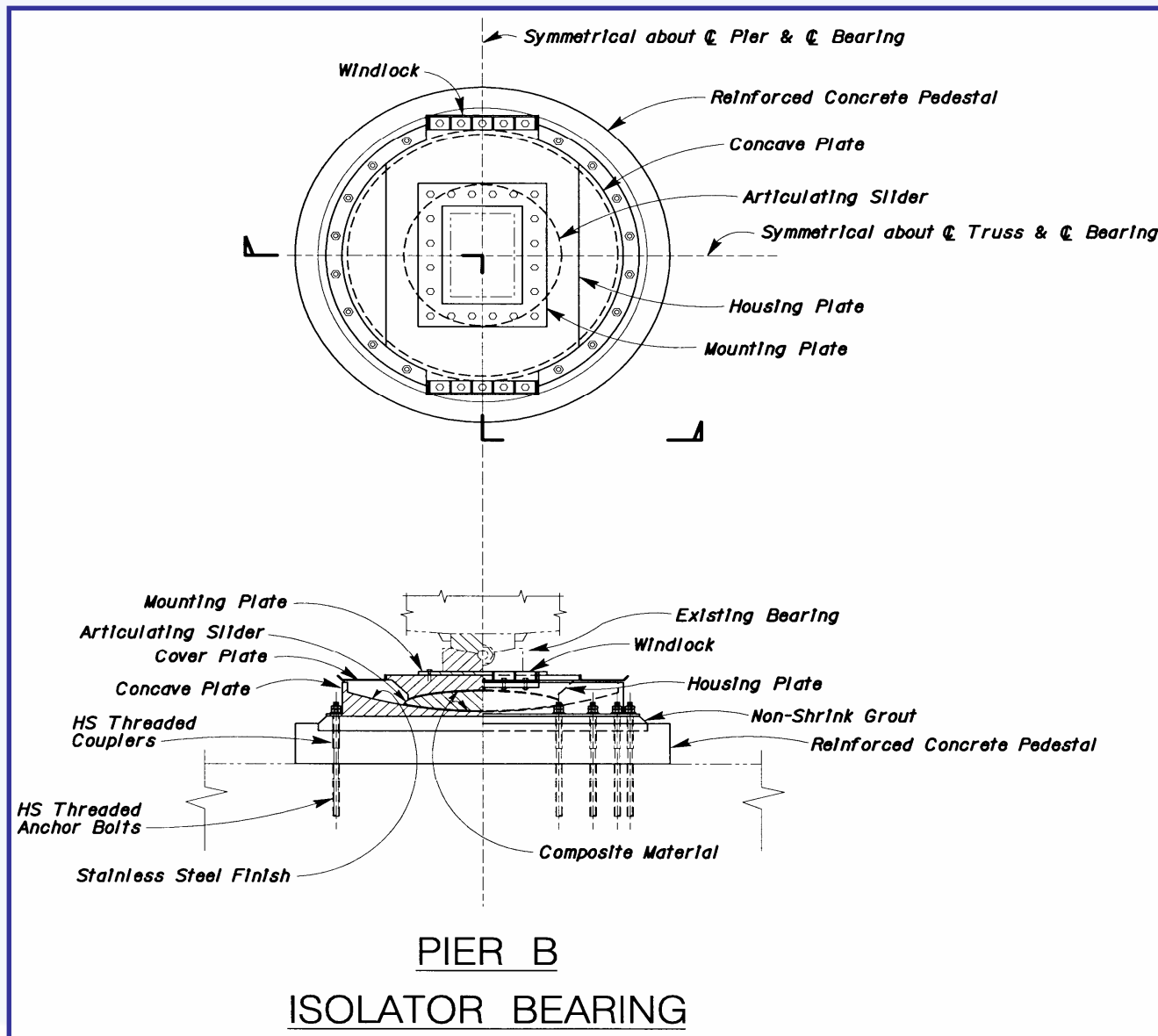

Lateral Stopper Blocks

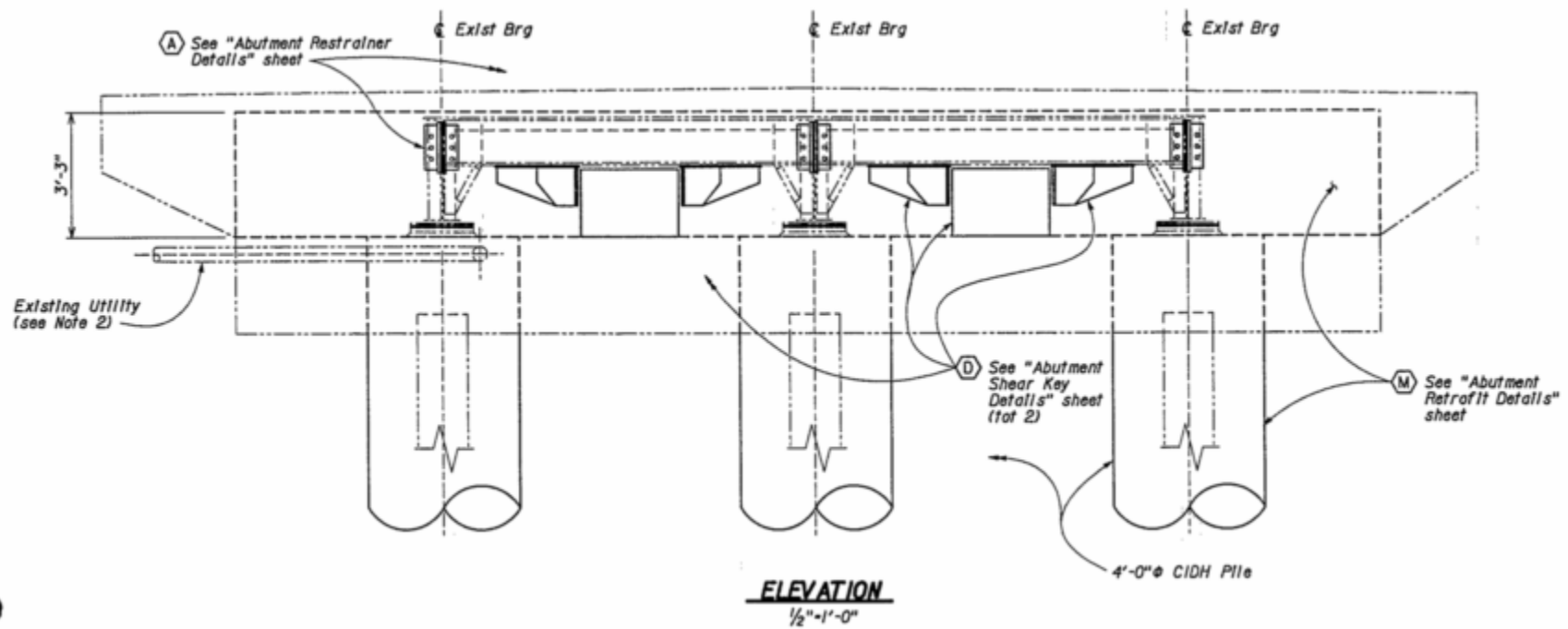

Vertical Catcher Blocker/Future Jacking Assembly

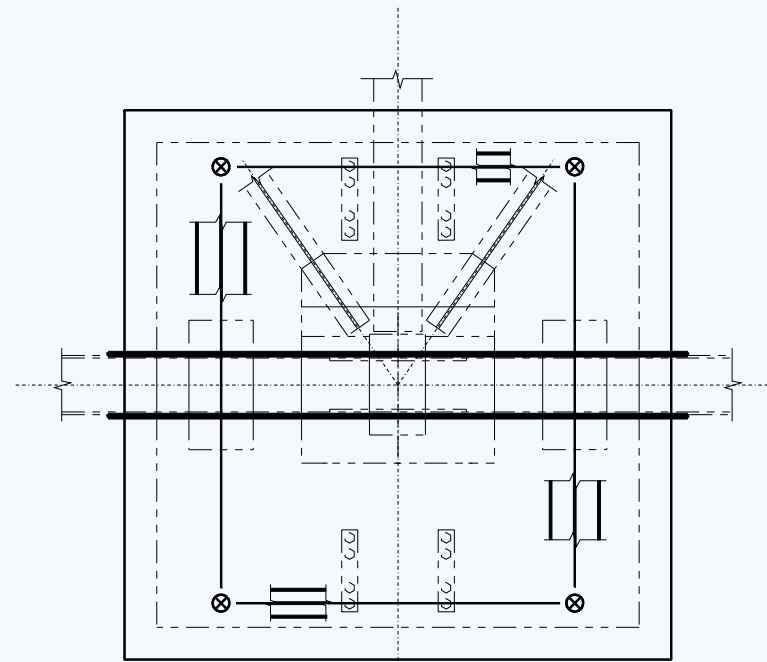
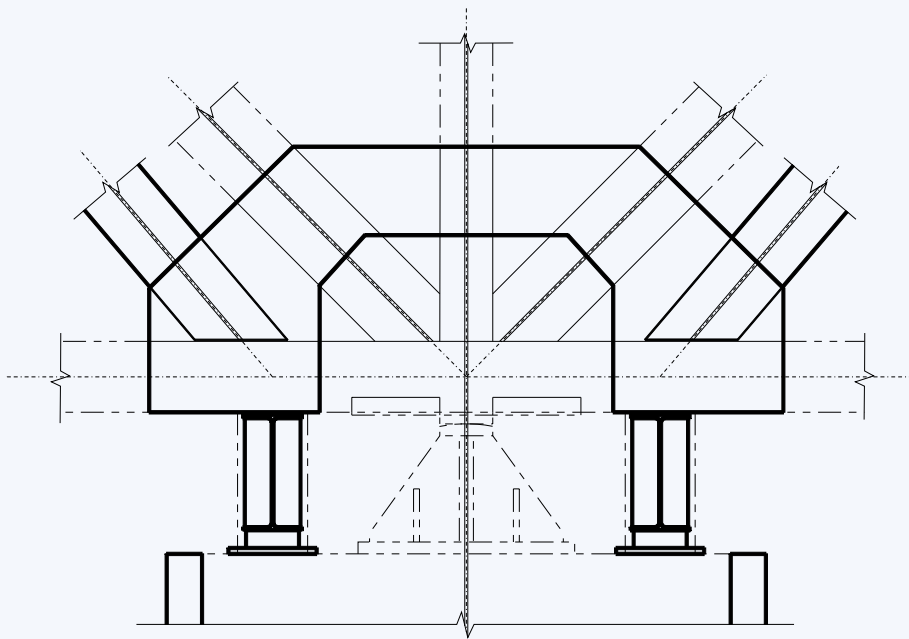

\$5000

Key Structural Elements

- Foundations
- Piers
- Bearings
- **Superstructure (29 – 40)**



Steel Member Retrofit

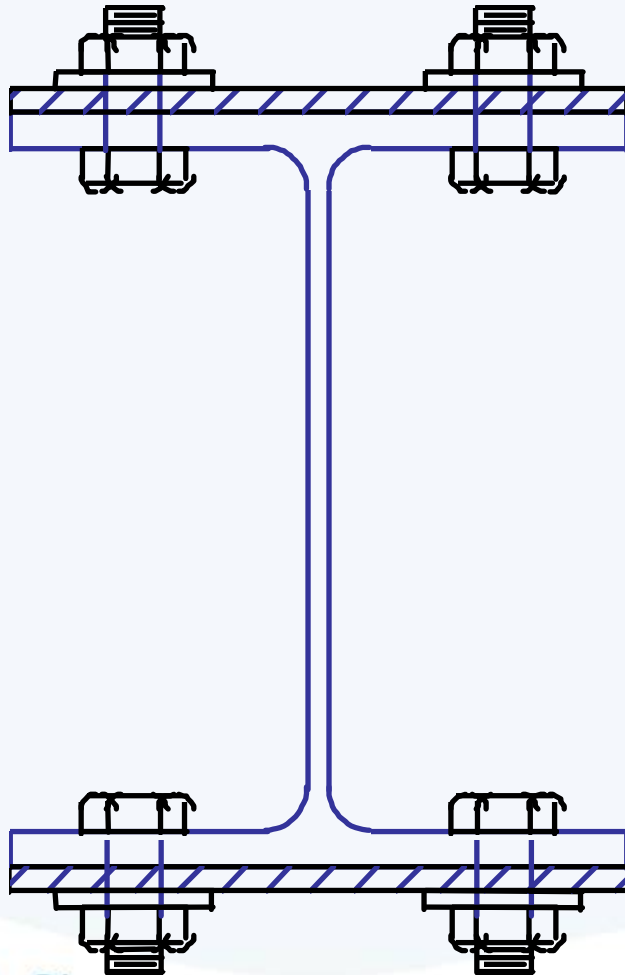

Retrofit Measures

- Add angles and plates to chords
- Strengthen portal cross frames
- Strengthen diagonal members
- Strengthen lateral bracing
- Replace towers
- Deck connections to beams
- Gusset plate replacement
- Stiffening gusset plates
- Connection strengthening
- Rivet and bolt replacements
- Replace of laced members
- Mechanical System
- Electrical System

Seismic Panel Cost Summary



General Seismic Performance Goals

	Performance	
Level I EQ	Service after Short Period Inspection	
Level II EQ		Safety No Collapse

		Serviceable		No Collapse	
		Low	High	Low	High
100y - 500y	Foundation	50	100	50	100
	Pier	10	30	10	30
	Bearing	6	6	6	6
	Superstructure	22	31	22	31
		88	167	88	167
500y - 1000y	Foundation	55	105	55	105
	Pier	10	30	10	30
	Bearing	9	9	9	9
	Superstructure	26	36	26	36
		100	180	100	180
500y - 2500y	Foundation	60	110	60	110
	Pier	10	30	10	30
	Bearing	13	13	13	13
	Superstructure	29	40	29	40
		112	193	112	193

Foundation - Add Large Dia Steel Caissons / Reinforced Concrete

Pier - Column Jacket + Wall Reinf

Bearing - Ret Bearing / Isolate

Superstructure - Connection & Member Strength @ Piers and Tower / or Isolation System

Seismic Panel Cost Caveats

- No cofferdam on lower bound foundation / pier costs
- Costs are bridge construction costs only
- No roadway surface improvements
- Little sub-structure & pier data for the Northbound Structure
- Costs do not reflect analysis but similar project costs
- Does not include life cycle costs
- All costs are present day costs
- Does not include:
 - Navigation considerations
 - Functional obsolescence

Seismic Panel Recommendations

- Analysis effort to advance retrofit concepts and tighten cost ranges
- Cost analysis of similar projects

Next Steps

- Complete current geotechnical analysis

Columbia River **CROSSING**

Questions and Discussion



Appendix C – Results of WSDOT Liquefaction Analysis



November 17, 2006

TO: Doug Ficco /Lynn Rust
Columbia River Crossing Project, S15

FROM:  Tony Allen/William Hegge
E&EP Geotechnical Division, 47365

SUBJECT: I-5, XL 1273, MP 0.0 to 3.0
Columbia River Crossing Project
Liquefaction, Lateral Spreading and Drilled Shaft Design
Preliminary Geotechnical Recommendations

1. INTRODUCTION

At your request, we have prepared the following technical memorandum that summarizes the results of our preliminary geotechnical recommendations for the proposed Columbia River Crossing project. Specifically, the purpose of this study is to evaluate the potential for liquefaction and lateral spreading at select locations along the project alignment to evaluate feasible drilled shaft capacities to support the proposed I-5 replacement bridges over the Columbia River as shown on the Vicinity Map and Site Plan (Figure 1 in Appendix A).

The analyses, conclusions, and recommendations provided in this report are based on the project description, and the site conditions existing at the time of our site visits. The exploratory borings are assumed to be representative of the subsurface conditions at the locations of the borings. If during construction, subsurface conditions differ from those described in the explorations, we should be advised immediately so that we may reevaluate our recommendations and provide assistance.

2. PROJECT DESCRIPTION

The proposed Columbia River Crossing project consists of replacing one or both of the existing north and south bound I-5 bridges over the Columbia River as well as other bridges and structures along the I-5 corridor north and south of the Columbia River bridges. At the present time the scope of the proposed project as well as the details of the proposed construction (to include the location of the replacement bridges over the Columbia River) are still under development.

3. SITE CONDITIONS

3.1. Topography

The existing bridges over the Columbia River along I-5 extend from Portland, Oregon to Vancouver, Washington within the Portland Basin sub-province. A hydrographic and geophysical investigation was conducted by David Evans and Associates, Inc to determine the river bottom bathymetry in the vicinity of the existing and proposed bridge alignments. Their February 2006 report titled "Columbia River Crossing: Hydrographic and Geophysical Investigation" contains the results of the bathymetry study. Cross sections at existing bridge piers and river bottom profiles along the existing bridge alignment were subsequently developed based on the results of the bathymetry study.

According to the report by David Evans and Associates, in the main channel of the Columbia River the average depth of the water is approximately 27 feet. Evidence of scouring exists on the upstream side of each existing bridge pier and scour channels extend on the downstream side. The scouring around existing bridge piers ranges is approximately 10 to 15 feet on average, but several piers show scouring of up to 30 feet. There are three notable mounds about 7 feet in height downstream of the existing bridge and one mound just upstream of the existing bridge. Numerous sandwaves are evident and are more distinct downstream of the existing bridge. The sandwaves in the middle of the river are regular and approximately 2 feet to 3 feet in height. The sandwaves on the northern, downstream side of the river are larger and more irregular than in the middle of the river and are about 5 feet in height. The area upstream of the bridge near the north bank is relatively smooth with little or no sandwaves, while the south bank side has irregular sandwaves about 3 feet in height.

3.2. Geology

The project site is located near the north end of the Willamette Valley physiographic province. The Willamette Valley is a broad lowland that separates the Oregon Coast Range on the west from the Cascade Range to the east. Structurally, this lowland has been subdivided into several smaller basins and narrow ridges underlain by 17 to 7 million year old Columbia River Basalt Group flows, including the Portland Basin, Stayton Basin, Tualatin Basin and several others. The project site is located at the western margin of the Portland Basin, just northeast of the northwest trending Tualatin Mountains, which separates the Portland Basin sub-province from the Tualatin Basin sub-province to the west. The Portland Basin is a northwest trending pull-apart basin bound by the Frontal Fault Zone to the east and the Portland Hills-Clackamas River Fault Zone on the west.

Locally, the project site is underlain by Pleistocene soils developed in unconsolidated interbedded silts and sands derived from catastrophic glacial Lake Missoula flood events. Between approximately 15,000 and 12,200 years ago, continental glaciers in Idaho and Montana regularly impounded melt water behind large glacial dams to form large lakes. As water levels became too high, the ice dams burst resulting in large catastrophic floods. Features such as the Channeled Scablands of eastern Washington resulted as the surging waters captured much of the loose sediment. As the floodwaters continued west to the ocean, they filled the Portland Basin and Willamette Valley as far south as Eugene. As the water slowed down, it released its sediment load as broad, level sand, silt and clay deposits. Evidence of at least 40 floods of varying sizes is evident in the sedimentary record. In the

project vicinity, these sediments are up to 100 feet thick. Within the channel of the Columbia River, the flood deposits have been reworked and transported by fluvial processes over approximately the last 10,000 years.

Underlying the flood sediments are semi-consolidated sands and gravels of the Troutdale Formation. The Troutdale Formation resulted from the development of the deposition of sediment from ancestral Columbia River erosion of the Cascade Range. This in turn is underlain by 17 to 7 million year old Columbia River basalts (CRB). The CRB were deposited over much of northwest and eastern Oregon, as well as southwest and eastern Washington. Although not exposed in the project vicinity, well data indicate that 56 to 34 million year old marine sedimentary rocks underlie the CRB, representing some of the oldest rocks in this part of the Pacific Northwest.

3.3. Soils

The subsurface conditions at the site of the proposed replacement bridges over the Columbia River fall into three broad areas of interest, the north abutment, the south abutment and within the river. This memorandum is only concerned with the subsurface conditions within the river.

Subsurface conditions within the river were explored in an exploration program in 2006, which included 3 borings located east (upstream) of the existing bridges. The locations of these borings, designated CRC-01-06 through CRC-03-06, are shown on the Vicinity Map/Site Plan (Figure 1 in Appendix A). Subsurface conditions at the locations within the river explored by WSDOT drill crews in 2006 are shown on the boring logs included in Appendix B. This appendix also includes a detailed discussion of the field exploration program. Boring logs presented herein should be made available to all prospective bidders and included in the contract documents. Appendix C provides a discussion of the laboratory testing program and applicable test results.

The soil deposits encountered in the test borings have been grouped into soil units for geotechnical distinction. The soil units are grouped primarily on the basis of engineering properties and classification, and in general, reflect depositional environments as well. The general project soil units are as follows:

Unit 1 consists of very loose to dense sand that appears to be Pleistocene glacial flood deposits. The upper 30 to 45 feet of this material has been transported and deposited as river alluvium. This material generally increases in density and shear strength with depth, varying from 115 pounds per cubic foot and phi of 30 degrees near the surface to 127 pounds per cubic foot and phi of 35 degrees near the base of this unit.

Unit 2 consists of very dense sand and gravel that is cemented in some areas. This deposit is known as the Troutdale Formation and underlies younger soils across most of the Portland basin. The Troutdale formation at the project site consists of rounded gravels up to 3 inches in diameter within a sand matrix. This matrix is yellowish orange in color and was strong enough to survive the drilling/coring process in CRC-01-06. In CRC-02-06 and CRC-03-06, this matrix is black in color and was not strong enough to survive the drilling/coring process.

3.4. Groundwater

The entire area explored in this phase of the field investigations is located within the Columbia River where the maximum groundwater level is the river level.

4. SEISMOLOGICAL CONSIDERATIONS

4.1 Design Earthquake Parameters

It is our understanding that preliminary seismic design will include the peak ground acceleration and mean earthquake magnitude for the 100, 200, 500, 1000 and 2500 year earthquake events. Peak horizontal bedrock accelerations and mean earthquake magnitude were determined for the site location using the USGS 2002 (updated 2003) deaggregation data, which takes into account the distance, magnitude, and likelihood of activity for various known faults near the site location. Based on the subsurface information contained in borings CRC-RC-001, CRC-RC-002 and CRC-RC-003, the site soils are generally categorized as type E soils according to the NEHRP classification developed by Stewart et al. (2003). Appropriate amplification factors for Class E soils were applied to the peak bedrock acceleration values to estimate the amplified peak ground accelerations. These amplified values of acceleration were used in liquefaction analysis to determine the depth of the liquefiable zones at each boring. A summary of the results of the seismic deaggregation are shown in Table 1 below for the 100, 200, 500, 1000 and 2500 year earthquake design scenarios.

Table 1. Seismic Deaggregation for Design Earthquake Events

Design Seismic Event	Peak Horizontal Bedrock Acceleration	Amplification Factor for Soil Type	Peak Horizontal Ground Acceleration	Mean Earthquake Magnitude (Mw)	Mean Distance (km)
100 Yr. Event	0.08 g	2.0	0.16	6.61	59.5
200 Yr Event	0.13 g	1.5	0.20	6.76	52.2
500 Yr Event	0.19 g	1.3	0.24	6.82	45.4
1000 Yr Event	0.27 g	1.1	0.29	6.81	38.2
2500 Yr Event	0.39 g	0.9	0.34	6.74	29.3

Design response spectra presented in the AASHTO guide specifications for seismic design of highway bridges are considered appropriate for seismic design of the Columbia River Crossing project. A Type II Soil Profile response spectrum, with a Site Coefficient of 1.2 is recommended for seismic design.

4.2. Liquefaction Potential

Soil liquefaction is a phenomenon whereby saturated soil deposits temporarily lose strength and behave as a viscous fluid in response to cyclic loading. Soil types considered at the highest risk of liquefaction during a seismic event are loose sandy soils. Analyses of soils encountered in the test borings indicate that the following areas shown in Table 2 are subject to liquefaction:

Table 2. Liquefiable Soils

Boring	Design Seismic Event	Depth of Liquefiable Zone* (feet)	Elevation of Liquefiable Zone* (feet, NAVD 88 Datum)
CRC-RC-001	100 Year	0 to 46	-21.2 to -67.2
“	200 Year	0 to 56	-21.2 to -77.2
“	500 Year	0 to 73	-21.2 to -94.2
“	1000 Year	0 to 75	-21.2 to -96.2
“	2500 Year	0 to 75	-21.2 to -96.2
CRC-RC-002	100 Year	0 to 13	-18.5 to 31.5
“	200 Year	0 to 22	-18.5 to -40.5
“	500 Year	0 to 26	-18.5 to -44.5
“	1000 Year	0 to 46	-18.5 to -64.5
“	2500 Year	0 to 75	-18.5 to -93.5
CRC-RC-003	100 Year	None	N/A
“	200 Year	None	N/A
“	500 Year	0 to 28	-36.8 to -64.8
“	1000 Year	0 to 37	-36.8 to -73.8
“	2500 Year	0 to 61	-36.8 to -97.8

* Factor of safety against Liquefaction less than 1.2 as determined by the Seed and Idriss Method.

Based upon the available subsurface information, all of the in-water piers for the proposed replacement bridges should be designed to resist the effects of soil liquefaction.

4.3 Lateral Spreading

Lateral spreading is a phenomenon whereby soil deposits that have liquefied move downslope, creating tension cracks, settlement, and slope failure. The scope of our analysis was limited to the bathymetry within the river bottom. We anticipate that the potential for lateral spreading of the river banks on the Washington and the Oregon side of the river will be determined in a future phase of this project. Using river bottom bathymetry provided by the Columbia River Crossing project team, we observed that severe scour at the pier locations has exposed oversteepened slopes adjacent to the piers. Using cross sections at pier locations along the existing Columbia River Crossing alignment provided by the Columbia River Crossing project team, we identified oversteepened slopes that appear to be susceptible to liquefaction induced slope instability that could result in significant lateral displacement during a seismic event.

We analyzed the lateral spreading potential of these oversteepened slopes at the locations of the three existing bridge piers where the scour appears to be the most severe. We concluded that the geometry of the river bottom in the cross section at the location of existing Pier No. 3 provided the highest estimate of lateral displacements. Therefore, the geometry at this pier was used to estimate the lateral displacements which may occur under the 100, 200, 500, 1000 and 2500 year design earthquake scenarios. The results of these analyses are

summarized in Table 3 below. The results shown in Table 3 indicate that significant lateral movements can be expected for all design earthquake scenarios.

Table 3. Liquefaction Induced Horizontal Displacements

Design Seismic Event	Estimated Horizontal Displacement (ft)
100 year	0.3
200 Year	0.8
500 Year	1.2
1000 Year	1.8
2500 Year	2.7

5. GEOTECHNICAL RECOMMENDATIONS

5.1. Scour Potential

Only one design scenario was considered in the development of the geotechnical foundation design parameters. This scenario did not include any scour at the shaft locations. The design scenario used the topographical conditions existing at the time of drilling except for removal of the surface riprap layer observed in CRC-RC-003. This was done because this layer would have to be removed to construct the shafts. This scour potential is important because of the potential for liquefaction and downdrag upon the shafts in the near surface soils. If these soils are left in place, the seismic loading acting on the shafts should include downdrag loads. If some of these soils are removed by scour, some of the downdrag loads acting on the shaft during seismic loading would be reduced. Since we do not have predictions of scour at this time, we have chosen to leave it out of the analyses at this stage of the project.

5.2. Drilled Shaft Axial Capacities

We understand that the bridge structure and substructure design will be performed using Load and Resistance Factored Design (LRFD) methodology. In accordance with this methodology, we have provided axial capacities for nominal strength (ultimate), service and extreme limit states on charts in Appendix D. These charts include nominal capacities for end bearing and skin friction resistance for 10 and 12-foot diameter shafts at the locations of borings CRC-RC-001, CRC-RC-002 and CRC-RC-003. Shaft uplift capacity for the strength and extreme event limit cases can also be taken directly from the capacity charts, where the unit uplift resistance is taken as equal to the unit skin friction. Note that the capacity charts do not account for the net weight of the shafts, which should be added as a separate load when sizing the shafts (for both compression and uplift).

5.2.1. Liquefaction

As a result of liquefaction, skin friction accounted for under static loading cases will no longer be available within the liquefiable layers. Consequently, ultimate shaft capacities should be modified due to the loss of support in the liquefiable zones. The extreme limit

state curves shown on the charts in Appendix D should be reduced by the Q_s values presented in Table 4 below.

Table 4. Ultimate Skin Friction Loss

Boring	Design Seismic Event	Q_s per shaft (kips)	
		10-Foot Shaft	12-Foot Shaft
CRC-RC-001	100 Year	860	1030
"	200 Year	1350	1620
"	500 Year	2180	2610
"	1000 Year	2270	2720
"	2500 Year	2270	2720
CRC-RC-001	100 Year	90	100
"	200 Year	230	270
"	500 Year	360	430
"	1000 Year	1280	1540
"	2500 Year	2750	3300
CRC-RC-001	100 Year	0	0
"	200 Year	0	0
"	500 Year	660	790
"	1000 Year	1070	1280
"	2500 Year	2310	2770

5.2.3. Downdrag

Following the occurrence of liquefaction, consolidation of the liquefiable soil units will be significant enough to mobilize downward movement of the soils around the shafts and cause downdrag loads to develop during an earthquake. Downdrag loads due to liquefaction are provided in Table 5 below for each boring location.

Table 5. Downdrag Loads

Boring	Design Seismic Event	Load per shaft (kips)	
		10-Foot Shaft	12-Foot Shaft
CRC-RC-001	100 Year	860	1030
"	200 Year	1350	1620
"	500 Year	2180	2610
"	1000 Year	2270	2720
"	2500 Year	2270	2720

Table 5. Downdrag Loads (Continued)

Boring	Design Seismic Event	Load per shaft (kips)	
		10-Foot Shaft	12-Foot Shaft
CRC-RC-002	100 Year	90	100
"	200 Year	230	270
"	500 Year	360	430
"	1000 Year	1280	1540
"	2500 Year	2750	3300
CRC-RC-003	100 Year	0	0
"	200 Year	0	0
"	500 Year	660	790
"	1000 Year	1070	1280
"	2500 Year	2310	2770

These loads should be added to the factored bridge loads when evaluating the extreme event limit state for the “pre-scour” scenario only (or existing condition). If scour is included in later analyses, the downdrag from liquefiable soils within the scour zone should not be included in the analyses since this zone of the liquefiable soils would be removed, or scoured away, and consequently no downdrag loading would occur from that soil zone. Based on observation of scouring at the existing bridge piers, we anticipate that downdrag loading within approximately the upper 30 feet may be neglected.

5.2.5 Resistance Factors

Resistance factors for bearing capacity and uplift for service, strength, and extreme limit states are shown in Table 6 below:

Table 6. Drilled Shaft Resistance Factors

Limit State	Resistance Factor ϕ		
	Skin Friction	End Bearing	Uplift
Strength	0.55	0.55	0.45
Service	1.00	1.00	N/A
Extreme	1.00	1.00	0.80

After appropriate factoring (see above table) of the service and extreme event limit states charts shown in Appendix D, 1 inch and 6 inches of settlement, respectively, are required to mobilize these ultimate nominal capacities. Minimum tip elevations should be determined using these capacity charts and the required loading for the appropriate design limit state.

5.2.6. Group Effects

Drilling a hole for a shaft less than 3.0 shaft diameters from an existing shaft reduces the effective stresses against both the side and base of the existing shaft. As a result, the axial capacities of individual drilled shafts within a group tend to be less than the corresponding capacities of isolated shafts. The drilled shafts at this project site are constructed in

cohesionless soil. Therefore, regardless of cap contact with the ground, the individual nominal resistance of each shaft shall be reduced by a factor η for an isolated shaft taken as:

- $\eta = 0.65$ for a center-to-center spacing of 2.5 diameters.
- $\eta = 1.0$ for a center-to-spacing of 6.0 diameters.

For intermediate spacings, the value of n may be determined by linear interpolation.

5.2.7. Minimum Tip Elevations

We understand from our conversations with the WSDOT Bridge & Structures Office that post-construction settlement of the drilled shafts should not exceed 1 inch. To achieve less than 1 inch of settlement, we recommend that the drilled shafts be extended to the depths listed in Table 7 below.

Table 7. Minimum Drilled Shaft Tip Elevations

Boring No.	Minimum Tip Elevation (Feet, NAVD 88 Datum)
CRC-RC-001	-105
CRC-RC-002	-217
CRC-RC-003	-217

5.3 Lateral Analysis of Shafts

5.3.1 Liquefaction Induced Lateral Loading

As described previously, we determined that liquefaction induced slope instability may result in significant lateral displacements at the new pier locations for all design earthquake scenarios. Based on the assumption that a similar extent of scour will develop at new pier locations, the new piers should be designed to resist any additional lateral loading caused by liquefaction induced slope failures under extreme state conditions. Since the pier locations and scour depth have not been determined, we did not attempt to estimate the lateral pressures induced by liquefaction induced slope instability at this time. Estimation of these lateral pressures should occur during a later phase of this project when the pier locations and scour depth have been determined. These lateral pressures should be used in the extreme limit state design of drilled shafts for all design earthquake scenarios.

5.3.2 Lateral Resistance

We understand that lateral analysis of drilled shafts will be evaluated using the DFSAP computer program. Since the pier locations have not been determined, we developed the lateral parameters based on the subsurface conditions in borings CRC-RC-001, CRC-RC-002 and CRC-RC-003. Soil parameters used for DFSAP input at each boring are included in Appendix E for static conditions and seismic conditions under the 100, 500, 1000 and 2500 year design earthquake scenarios. For each design earthquake scenario, we have adjusted the DFSAP parameters to account for the loss of soil strength due to anticipated liquefaction. We anticipate that the condition and strength of the soil units will return to near normal static

conditions within one week after the design earthquake. A scour analysis was not performed as part of this phase of the project. Once the scour depth and pier locations have been determined, the DFSAP parameters should be adjusted to reflect the loss of lateral support above the scour elevation.

6. CONSTRUCTION CONSIDERATIONS

6.1. Drilled Shafts

Casing installation will be difficult. The proposed drilled shaft and casing lengths are very long, in excess of 150 feet. The contractor will likely need casing with a substantial wall thickness to withstand handling, driving and installation stresses. In addition, the tip of the casing will likely require reinforcement or a cutting shoe to maintain the casing shape and enable the casing to be advanced into very dense materials.

Drilled shafts at the project site will require the use of temporary casing at all of the pier locations because of the elevation of the river level and/or the presence of relatively loose sand and gravel deposits that can be susceptible to caving. Since it is not possible to advance casing into intact Troutdale Formation, the temporary casing will have to be seated on top of the intact Troutdale Formation. Therefore, we suggest casing be installed to the minimum tip elevations shown in Table 8 below.

Table 8. Minimum Temporary Casing Tip Elevations

Boring No.	Minimum Casing Tip Elevation (feet, NAVD 88 Datum)
CRC-RC-001	-125
CRC-RC-002	-221
CRC-RC-003	-217

The groundwater and surface water levels encountered at the proposed site will require that the drilled shafts be constructed “in the wet” using a slurry construction method. For shafts constructed “in the wet” cross-hole sonic logging (CSL) tests will be required.

7. Intended Use and Limitations

This report has been prepared to assist the Washington State Department of Transportation in the engineering design and construction of the subject project. It should not be used, in part or in whole for other purposes without contacting the EEP Geotechnical Division for a review of the applicability of such reuse. This report should be made available to prospective contractors for their information or factual data only and not as a warranty of ground conditions.

The conclusions and recommendations contained in this report are based on the Geotechnical Division’s understanding of the project at the time that the report was written and on site conditions that existed at time of the field exploration. If significant changes to the nature, configuration, or scope of the project occur during the design process, the Geotechnical

Division should be consulted to determine the impact of such changes on the recommendations and conclusions presented in this report.

Site exploration and testing describes subsurface conditions only at the sites of subsurface exploration and at the intervals where samples are collected. These data are interpreted by members of the Geotechnical Division who then render an opinion regarding the general subsurface conditions. The distribution, continuity, thickness, and characteristics of identified (and unidentified) subsurface materials may vary considerably from that indicated by the subsurface data. While nothing can be done to prevent such variability, the Geotechnical Division is prepared to work with the Design Team to reduce the impacts of variability on project design, construction, and performance. Periodic geotechnical observation during construction may be beneficial in this respect. This ongoing involvement of the Geotechnical Division throughout the design and project development process will also help to avoid costly mistakes associated with misinterpretation of the contents of this report and resulting shortcomings of project design or contract documents.

The conclusions and recommendations presented in this report assume that surface and subsurface conditions, as observed during field exploration activities are representative of the site conditions throughout the project area. Because of this assumption, these recommendations should be considered preliminary in nature. Actual subsurface conditions can be discovered only during earthwork and construction operations. Accordingly, the Geotechnical Division should be involved in the construction of the project in order to make appropriate observations and recommendations for alteration in design, as appropriate.

TMA/JC:wh

If you have questions or require further information, please contact Tony Allen at (360) 709-5450 or William Hegge at (360) 709-5415.



11/16/06

Chris Heather

Prepared By:
Christopher Heathman.
Geotechnical Engineer

Prepared By:
William S. Hegge P.E.
Senior Foundations Engineer



Reviewed By:
James Cuthbertson P.E.
Chief Foundations Engineer

- TMA/wsh
Appendix A – Figures
Appendix B – Field Explorations
Appendix C – Laboratory Test Results
Appendix D – Axial Capacity Charts for Drilled Shafts
Appendix E – DFSAP Input Parameters

cc: *M. Anderson, OSC Bridge and Structures Office MS 47340*
M. Shekhizadeh, OSC Bridge Construction Office, 47354
P. Kinderman, OSC Bridge and Structures Office MS 47340

APPENDIX A – FIGURES

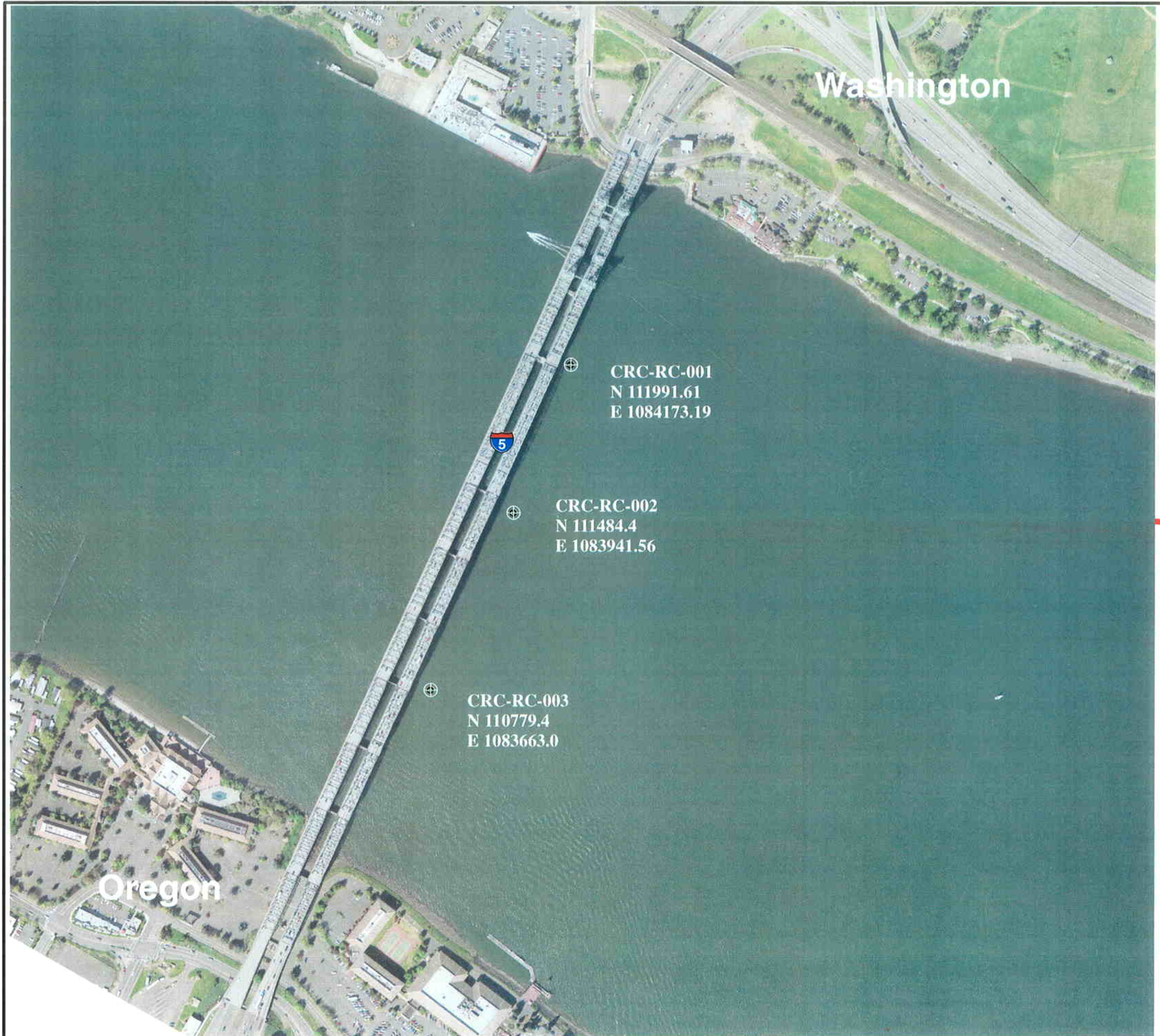

Washington

⊕ CRC-RC-001
N 111991.61
E 1084173.19

⊕ CRC-RC-002
N 111484.4
E 1083941.56

⊕ CRC-RC-003
N 110779.4
E 1083663.0

Oregon

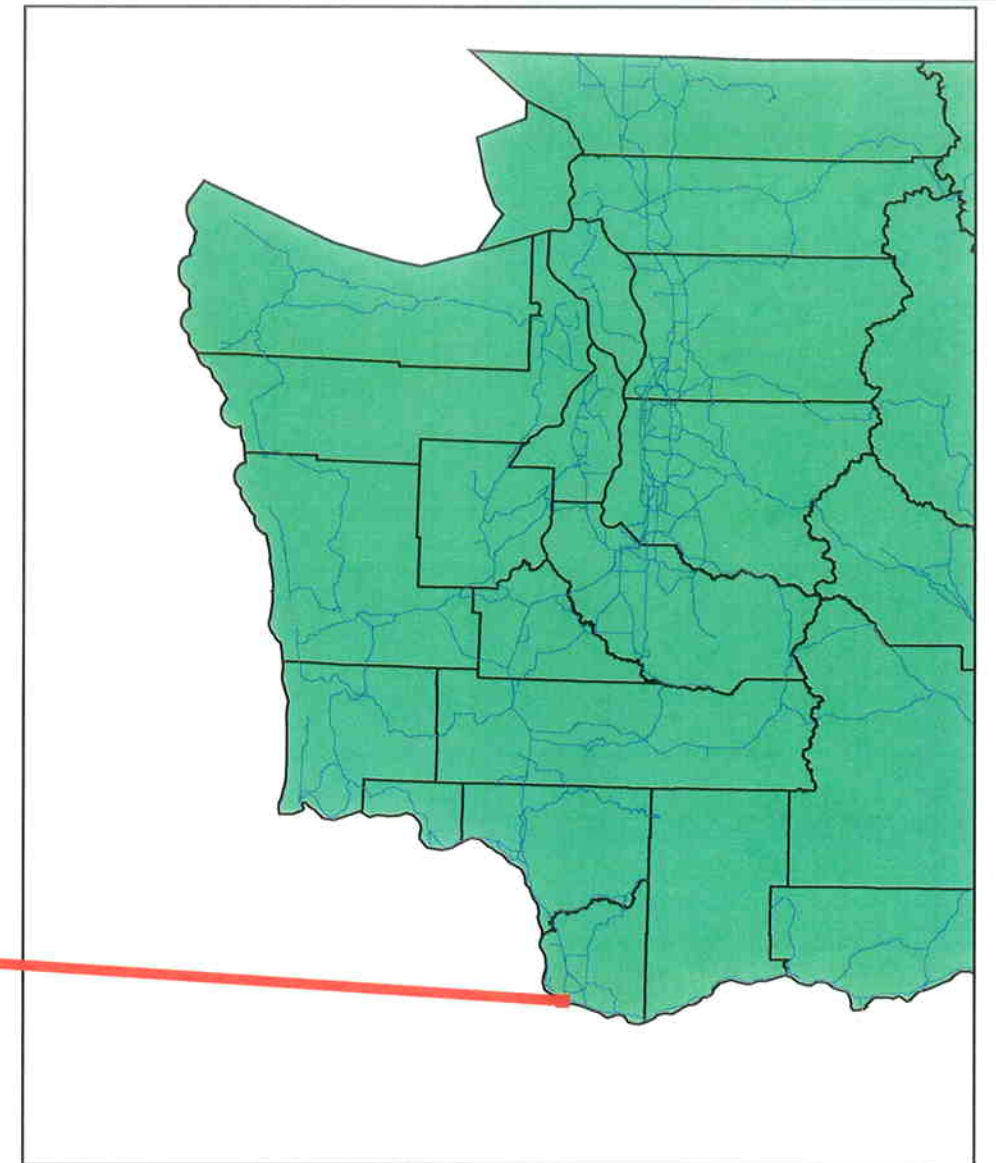

⊕ Borings with designation and NAD 1983 State plane Washington South coordinates

Job XL-2268 SR 5

I-5 Columbia River Crossing



Washington State
Department of Transportation

Geotechnical Division

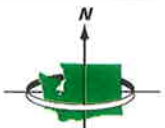

0 62.5 125 250 375 500 Feet

Figure 1: Site and Vicinity Map

APPENDIX B – FIELD EXPLORATION PROGAM

FIELD EXPLORATION PROGRAM

To form a preliminary characterization of the subsurface conditions within the Columbia River in the vicinity of the existing bridges, WSDOT Headquarters drill crews drilled three borings within the Columbia River.

The in-water exploratory borings were drilled using a skid-mounted CME 45 drill rig from a barge. The locations of these borings (as determined through Global Positioning System (GPS) measurements) are shown on the Vicinity Map and Site Plan (Figure 1 in this Appendix). All of the borings were advanced using wet rotary drilling and methods to the depths and elevations described above. Where difficult drilling in gravels was encountered, the boring was advanced using rock-coring techniques. Rock coring techniques were also used to advance the borings into the Troutdale Formation. This rock coring was accomplished using a HQ x 40.0 triple tube wireline coring system powered by the same drill rig. Soil samples were obtained during drilling using a SPT (Standard Penetration Test) sampler, in general accordance with ASTM D-1586. SPT's are obtained by driving a 2-inch outside diameter split-spoon sampler 18 inches into the soil with a 140-pound hammer. The number of blows required to achieve each 6 inches of penetration is recorded and the soil's SPT resistance, or N-value, is calculated as the number of blows required to achieve the final 12 inches of penetration. The skid-mounted drill rig is equipped with an automatic trip hammer to drive the split-spoon sampler. The automatic hammer is rated at approximately 80 percent efficiency, as compared to approximately 60 percent for manual hammers.

Following completion of the drilling program, select soil samples were then submitted to the Headquarters Materials Laboratory for laboratory testing. The soil samples from the SPT's were visually classified in the field then submitted to the Headquarters Materials Laboratory for more detailed classification and testing. Boring logs and a legend of the terms and symbols used or shown on the boring logs are included in this appendix and should be included in the contract documents.

The locations of the borings were determined by Global Positioning System methods. The elevations of the borings were determined by water depth measurements relative to reference points whose locations were determined by survey. The locations of the borings are shown on the Vicinity Map and Site Exploration Plan (Figure 1 in Appendix A).



Test Boring Legend

Sampler Symbols	
	Standard Penetration Test
	Oversized Penetration Test (Dames & Moore, California)
	Shelby Tube
	Piston Sample
	Washington Undisturbed
	Vane Shear Test
	Core
	Becker Hammer
	Bag Sample

Well Symbols	
	Cement Surface Seal
	Piezometer Pipe in Granular Bentonite Seal
	Piezometer Pipe in Sand
	Well Screen in Sand
	Granular Bentonite Bottom Seal
	Inclinometer Casing in Concrete Bentonite Grout

Laboratory Testing Codes	
UU	Unconsolidated Undrained Triaxial
CU	Consolidated Undrained Triaxial
CD	Consolidated Drained Triaxial
UC	Unconfined Compression Test
DS	Direct Shear Test
CN	Consolidation Test
GS	Grain Size Distribution
MC	Moisture Content
SG	Specific Gravity
OR	Organic Content
DN	Density
AL	Atterberg Limits
PT	Point Load Compressive Test
SL	Slake Test
DG	Degradation
LA	LA Abrasion
HT	Hydrometer Test

Soil Density Modifiers			
Gravel, Sand & Non-plastic Silt		Elastic Silts and Clay	
SPT Blows/ft	Density	SPT Blows/ft	Consistency
0-4	Very Loose	0-1	Very Soft
5-10	Loose	2-4	Soft
11-24	Medium Dense	5-8	Medium Stiff
25-50	Dense	9-15	Stiff
>50	Very Dense	16-30	Very Stiff
		31-60	Hard
		>60	Very Hard

Angularity of Gravel & Cobbles	
Angular	Coarse particles have sharp edges and relatively plane sides with unpolished surfaces.
Subangular	Coarse grained particles are similar to angular but have rounded edges.
Subrounded	Coarse grained particles have nearly plane sides but have well rounded corners and edges.
Rounded	Coarse grained particles have smoothly curved sides and no edges.

Soil Moisture Modifiers	
Dry	Absence of moisture; dusty, dry to touch
Moist	Damp but no visible water
Wet	Visible free water

Soil Structure	
Stratified	Alternating layers of varying material or color at least 6mm thick; note thickness and inclination.
Laminated	Alternating layers of varying material or color less than 6mm thick; note thickness and inclination.
Fissured	Breaks along definite planes of fracture with little resistance to fracturing.
Slickensided	Fracture planes appear polished or glossy, sometimes striated.
Blocky	Cohesive soil that can be broken down into smaller angular lumps which resist further breakdown.
Disrupted	Soil structure is broken and mixed. Infers that material has moved substantially - landslide debris.
Homogeneous	Same color and appearance throughout.

HCL Reaction	
No HCL Reaction	No visible reaction.
Weak HCL Reaction	Some reaction with bubbles forming slowly.
Strong HCL Reaction	Violent reaction with bubbles forming immediately.

Degree of Vesicularity of Pyroclastic Rocks	
Slightly Vesicular	5 to 10 percent of total
Moderately Vesicular	10 to 25 percent of total
Highly Vesicular	25 to 50 percent of total
Scoriaceous	Greater than 50 percent of total



Test Boring Legend

Grain Size		
Fine Grained	< 1mm	Few crystal boundaries/grains are distinguishable in the field or with hand lens.
Medium Grained	1mm to 5mm	Most crystal boundaries/grains are distinguishable with the aid of a hand lens.
Coarse Grained	> 5mm	Most crystal boundaries/grains are distinguishable with the naked eye.

Weathered State		
Term	Description	Grade
Fresh	No visible sign of rock material weathering; perhaps slight discoloration in major discontinuity surfaces.	I
Slightly Weathered	Discoloration indicates weathering of rock material and discontinuity surfaces. All the rock material may be discolored by weathering and may be somewhat weaker externally than its fresh condition.	II
Moderately Weathered	Less than half of the rock material is decomposed and/or disintegrated to soil. Fresh or discolored rock is present either as a continuous framework or as core stones.	III
Highly Weathered	More than half of the rock material is decomposed and/or disintegrated to soil. Fresh or discolored rock is present either as discontinuous framework or as core stone.	IV
Completely Weathered	All rock material is decomposed and/or disintegrated to soil. The original mass structure is still largely intact.	V
Residual Soil	All rock material is converted to soil. The mass structure and material fabric is destroyed. There is a large change in volume, but the soil has not been significantly transported.	VI

Relative Rock Strength			
Grade	Description	Field Identification	Uniaxial Compressive Strength approx
R1	Very Weak	Specimen crumbles under sharp blow from point of geological hammer, and can be cut with a pocket knife.	1 to 25 MPa
R2	Moderately Weak	Shallow cuts or scrapes can be made in a specimen with a pocket knife. Geological hammer point indents deeply with firm blow.	25 to 50 MPa
R3	Moderately Strong	Specimen cannot be scraped or cut with a pocket knife, shallow indentation can be made under firm blows from a hammer.	50 to 100 MPa
R4	Strong	Specimen breaks with one firm blow from the hammer end of a geological hammer.	100 to 200 MPa
R5	Very Strong	Specimen requires many blows of a geological hammer to break intact sample.	Greater than 200 MPa

Discontinuities			
Spacing		Condition	
Very Widely	Greater than 3 m	Excellent	Very rough surfaces, no separation, hard discontinuity wall
Widely	1 m to 3 m	Good	Slightly rough surfaces, separation less than 1 mm, hard discontinuity wall.
Moderately	0.3 m to 1 m	Fair	Slightly rough surfaces, separation greater than 1 mm, soft discontinuity wall.
Closely	50 mm to 300 mm	Poor	Slickensided surfaces, or soft gouge less than 5 mm thick, or open discontinuities 1 to 5 mm.
Very Closely	Less than 50 mm	Very Poor	Soft gouge greater than 5 mm thick, or open discontinuities greater than 5 mm.
<p style="text-align: center;">RQD (%)</p> $\frac{100(\text{length of core in pieces} > 100\text{mm})}{\text{Length of core run}}$			

Fracture Frequency (FF) is the average number of fractures per 300 mm of core. Does not include mechanical breaks caused by drilling or handling.

G:\Text\BORLEGROCK 5/6/2003 2:02:33 PM



LOG OF TEST BORING

Start Card S-26251

Job No. XL-2268 SR SR-5 Elevation -21.2 ft

HOLE No. CRC-RC-001

Sheet 1 of 5

Project Columbia River Crossing

Driller Kerry Cooper Lic# 2552

Site Address Vicinity of I-5 @ Columbia River

Inspector Cleo Andrews

Start August 22, 2006 Completion August 23, 2006 Well ID# _____ Equipment CME 55 with Autohammer

Station _____ Offset _____ Hole Dia 4 (inches) Method Wet Rotary

Northing 111991.61 Easting 1084173.19 Latitude _____ Longitude _____

County Clark Subsection NE1/4 of NW1/4 Section 34 Range 1 EWM Township 2

Depth (ft)	Elevation (ft)	Profile	Field SPT (N) Moisture Content RQD	Blows/6" (N) and/or RQD FF	Sample Type Sample No. (Tube No.)	Lab Tests	Description of Material	Groundwater	Instrument
			20 40 60 80				0.0' to 1.0' Rip-Rap.		
							1.0' to 4.0' Sand with Gravel		
5	-25.0		◆	1 1 2 (3)	D-1		Poorly graded SAND, very loose, brownish gray, wet, homogenous, HCl not tested. Length Recovered 0.2 ft. Length Retained 0.2 ft.		
10	-30.0		◆ +	2 2 3 (5)	D-2	GS MC	SP, M.C. = 34% Poorly graded SAND, loose, dark brown, wet, homogenous, HCl not tested. Length Recovered 1.2 ft. Length Retained 1.0 ft.		
15	-35.0		◆ +	4 3 5 (8)	D-3	GS MC	SP, M.C. = 27% Poorly graded SAND, loose, gray with trace of reddish brown sand grains, wet, homogenous, HCl not tested. Length Recovered 0.5 ft. Length Retained 0.5 ft.		
20	-40.0		◆	5	D-4		Poorly graded SAND, loose, brownish gray with trace of		

SOILA XL-2268 SR-5 COLUMBIA RIVER CROSSING.GPJ SOIL GDT 11/16/06 7:45:43 A11



Depth (ft)	Elevation (ft)	Profile	Field SPT (N)				Blows/6" (N) and/or RQD FF	Sample Type	Sample No. (Tube No.)	Lab Tests	Description of Material	Groundwater	Instrument
			20	40	60	80							
							RQD 0.21 FF 23	C-22		Well graded conglomerate GRAVEL cemented with reddish brown sand, subrounded, gray, wet, stratified, HCl not tested. (Troutdale Formation) RQD=0.21, REC=21.67% FF=23			
100							RQD 0 FF 25	C-23		Well graded conglomerate GRAVEL cemented with reddish brown sand, subrounded, gray, wet, stratified, HCl not tested. (Troutdale Formation) RQD=0.0, REC=31% FF=25			
105										End of test hole boring at 104 ft below ground elevation. This is a summary Log of Test Boring. Soil/Rock descriptions are derived from visual field identifications and laboratory test data. Note REF = SPT Refusal			
110													
115													
120													

SOILA XL-2268 SR-5 COLUMBIA RIVER CROSSING GPJ SOIL GDT 11/16/06.7:45:44.A11



LOG OF TEST BORING

Start Card S-26251

Job No. XL-2268 SR SR-5 Elevation -18.5 ft

HOLE No. CRC-RC-002

Sheet 1 of 9

Project Columbia River Crossing

Driller Kerry Cooper Lic# 2552

Site Address Vicinity of I-5 @ Columbia River

Inspector Cleo Andrews

Start August 24, 2006 Completion August 26, 2006 Well ID# _____ Equipment CME 55 with Autohammer

Station _____ Offset _____ Hole Dia 4 Method Wet Rotary
(inches)

Northing 111484.40 Easting 1083941.56 Latitude _____ Longitude _____

County Clark Subsection NE1/4 of NW1/4 Section 34 Range 1 EWM Township 2

Depth (ft)	Elevation (ft)	Profile	Field SPT (N)				Blows/6" (N) and/or RQD FF	Sample Type	Sample No. (Tube No.)	Lab Tests	Description of Material	Groundwater	Instrument
			20	40	60	80							
5	-20.0							D-1			Poorly graded SAND, loose, brown, wet, homogenous, HCl not tested, 0.0' to 3.0' some rip-rap as indicated by drilling. Length Recovered 1.5 ft. Length Retained 1.0 ft.		
10	-25.0							D-2	GS MC		SP, MC=25% Poorly graded SAND, very loose, brown with trace of reddish brown sand grains, wet, homogenous, HCl not tested. Length Recovered 0.5 ft. Length Retained 0.5 ft.		
15	-30.0							D-3	GS MC		SP, MC=24% Poorly graded SAND, loose, dark brown with trace of reddish brown sand grains, wet, homogenous, HCl not tested. Length Recovered 1.5 ft. Length Retained 1.0 ft.		
20	-35.0							D-4			Poorly graded SAND, loose, brownish gray with trace of		

SOILA XL-2268 SR-5 COLUMBIA RIVER CROSSING GPJ SOIL GDT 11/16/06 2:07:26 P11



Depth (ft)	Elevation (ft)	Profile	Field SPT (N)				Blows/6" (N) and/or RQD FF	Sample Type	Sample No. (Tube No.)	Lab Tests	Description of Material	Groundwater	Instrument
			20	40	60	80							
40	-18.5						3 5 (8)				coarser and reddish brown sand grains, wet, homogenous, HCl not tested. Length Recovered 0.5 ft. Length Retained 0.5 ft.		
25	-33.5		◆	+			5 5 6 (11)	D-5	GS MC	SP, MC=24% Poorly graded SAND with trace of mica grains, medium dense, brownish gray, wet, homogenous, HCl not tested. Length Recovered 0.5 ft. Length Retained 0.5 ft.			
30	-38.5		◆	+			5 6 9 (15)	D-6	GS MC	SP, MC=29% Poorly graded SAND with trace of mica grains, medium dense, brownish gray, wet, homogenous, HCl not tested. Length Recovered 1.0 ft. Length Retained 1.0 ft.			
35	-43.5		◆				5 5 10 (15)	D-7		Poorly graded SAND with trace of mica grains, medium dense, brownish gray, wet, homogenous, HCl not tested. Length Recovered 1.5 ft. Length Retained 1.0 ft.			
40	-48.5		◆				5 6 8 (14)	D-8		Poorly graded SAND with trace of mica grains, medium dense, brownish gray, wet, homogenous, HCl not tested. Length Recovered 1.0 ft. Length Retained 1.0 ft.			
45	-53.5		◆										

SOILA XL-2268 SR-5 COLUMBIA RIVER CROSSING GPJ SOIL GDT 11/16/06.2.07.26 P11



Depth (ft)	Elevation (ft)	Profile	Field SPT (N)				Blows/6" (N) and/or RQD FF	Sample Type	Sample No. (Tube No.)	Lab Tests	Description of Material	Groundwater	Instrument
			20	40	60	80							
65	-65		◆				4 5 8 (13)	D-9			Poorly graded SAND with trace of mica grains, medium dense, brownish gray with trace of reddish brown sand grains, wet, homogenous, HCl not tested. Length Recovered 1.0 ft. Length Retained 1.0 ft.		
50	-70		◆	+			6 10 10 (20)	D-10	GS MC		SP, MC=26% Poorly graded SAND with trace of mica grains, medium dense, gray, wet, homogenous, HCl not tested. Length Recovered 1.0 ft. Length Retained 1.0 ft.		
55	-75		◆				7 11 12 (23)	D-11			Poorly graded SAND with traces of gravel and mica grains, medium dense, gray with trace of reddish brown sand grains, wet, homogenous, HCl not tested. Length Recovered 1.2 ft. Length Retained 1.0 ft.		
60	-80		◆				7 9 7 (16)	D-12			Poorly graded SAND with silt and traces of subrounded gravel and mica grains, medium dense, gray with trace of reddish brown sand grains, wet, homogenous, HCl not tested. Length Recovered 1.5 ft. Length Retained 1.0 ft.		
65	-85		◆	+			7 12 18 (30)	D-13	GS MC		SP-SM, MC=24% Poorly graded SAND with silt and trace of mica grains, dense, gray with trace of reddish brown sand grains, wet, homogenous, HCl not tested. Length Recovered 1.5 ft. Length Retained 1.0 ft.		
70	-90												

SOILA XL-2268 SR-5 COLUMBIA RIVER CROSSING GPJ SOIL GDT 11/16/06 2:07:26 P11



Depth (ft)	Elevation (ft)	Profile	Field SPT (N)				Blows/6" (N) and/or RQD FF	Sample Type	Sample No. (Tube No.)	Lab Tests	Description of Material	Groundwater	Instrument
			20	40	60	80							
-90			◆				6 6 10 (16)	D-14			Poorly graded SAND with silt and trace of mica grains, medium dense, gray, wet, homogenous, HCl not tested. Length Recovered 1.5 ft. Length Retained 1.0 ft.		
-95			◆				12 12 12 (24)	D-15			Poorly graded SAND with silt and trace of mica grains, medium dense, gray, wet, homogenous, HCl not tested. Length Recovered 1.5 ft. Length Retained 1.0 ft.		
-100			◆	+			7 12 18 (30)	D-16	GS MC		SP, MC=25% Poorly graded SAND with decayed wood fragments, dense, gray, wet, stratified, HCl not tested. Length Recovered 1.5 ft. Length Retained 1.0 ft.		
-105			◆				4 7 10 (17)	D-17			Poorly graded SAND with silt and trace of mica grains, medium dense, gray, wet, homogenous, HCl not tested. Length Recovered 1.5 ft. Length Retained 1.0 ft.		
-110			+				7 11 16 (27)	D-18	GS MC		SP-SM, MC=28% Poorly graded SAND with silt and trace of mica grains, medium dense, gray, wet, homogenous, HCl not tested. Length Recovered 1.5 ft. Length Retained 1.0 ft.		

SOILA XL-2268 SR-5 COLUMBIA RIVER CROSSING GPJ_SOIL_GDT_11/16/06_2.07.27 P11



Depth (ft)	Elevation (ft)	Profile	Field SPT (N)				Blows/6" (N) and/or RQD FF	Sample Type	Sample No. (Tube No.)	Lab Tests	Description of Material	Groundwater	Instrument
			20	40	60	80							
-115			◆	+			6 2 3 (5)	D-19	GS MC	SP, MC=28% Poorly graded SAND, loose, gray, wet, homogenous, HCl not tested. Length Recovered 1.5 ft. Length Retained 1.0 ft.			
100 -120			◆	+			4 7 7 (14)	D-20	GS MC AL HT	SP-SM, MC=30, PI=NA Poorly graded SAND with silt, with 2" layer of ash, medium dense, gray, wet, stratified, HCl not tested. Length Recovered 1.0 ft. Length Retained 1.0 ft.			
105 -125													
110 -130			◆	+			5 7 10 (17)	D-21	GS MC	SP, MC=30% Poorly graded SAND, medium dense, gray, wet, HCl not tested. Length Recovered 1.0 ft. Length Retained 1.0 ft.			
115 -135													
120			◆				5	D-22		Poorly graded SAND with silt, medium dense, gray, wet,			

SOILA XL-2268 SR-5 COLUMBIA RIVER CROSSING GPJ SOIL GDT 11/16/06 2:07:27 P11



Depth (ft)	Elevation (ft)	Profile	Field SPT (N)				Blows/6" (N) and/or RQD FF	Sample Type	Sample No. (Tube No.)	Lab Tests	Description of Material	Groundwater	Instrument
			20	40	60	80							
	-140						8 10 (18)				HCl not tested. Length Recovered 1.5 ft. Length Retained 1.0 ft.		
	-125						10 10 28 (38)	D-23	GS MC	SP-SM, MC=25% Poorly graded SAND with silt, dense, gray, wet, homogenous, HCl not tested. Length Recovered 1.5 ft. Length Retained 1.0 ft.			
	-145												
	-130												
	-150												
	-135						7 12 16 (28)	D-24		Poorly graded SAND with silt, dense, gray, wet, homogenous, HCl not tested. Length Recovered 1.0 ft. Length Retained 1.0 ft.			
	-155												
	-140												
	-160												
	-145						11 13	D-25		Poorly graded SAND with silt, dense, gray, wet, homogenous, HCl not tested.			

SOILA_XL-2268_SR-5_COLUMBIA_RIVER_CROSSING_GPJ_SOIL_GDT_11/16/06_2.07.27_P.11



Depth (ft)	Elevation (ft)	Profile	RQD				Blows/6" (N) and/or RQD FF	Sample Type	Sample No. (Tube No.)	Lab Tests	Description of Material	Groundwater	Instrument
			20	40	60	80							
175	-195			40			12 19 21 (40)	D-28	GS MC	SP-SM, MC=22% Poorly graded SAND with silt, with seashells and a single 1 1/2" x 1" piece of gravel, dense, gray, wet, stratified, HCl not tested. Length Recovered 1.0 ft. Length Retained 1.0 ft.			
185	-205			40			14 20 21 (41)	D-29		Poorly graded SAND with silt, with a 2" layer of subrounded gravel, dense, gray, wet, stratified, HCl not tested. Length Recovered 1.0 ft. Length Retained 1.0 ft.			

SOILA XL-2268 SR-5 COLUMBIA RIVER CROSSING GPJ SOIL.GDT 11/16/06 2:07:28 P-11



Depth (ft)	Elevation (ft)	Profile	Field SPT (N) Moisture Content RQD	Blows/6" (N) and/or RQD FF	Sample Type Sample No. (Tube No.)	Lab Tests	Description of Material	Groundwater	Instrument
			20 40 60 80						
-215			◆◆	5 11 24 (35)	D-30	GS MC	SP-SM, MC=29% Poorly graded SAND with silt, with a 2" layer of seashells, wood debris, dense, gray with trace of reddish brown sand grains, wet, stratified, HCl not tested. Length Recovered 1.5 ft, Length Retained 1.0 ft.		
200				RQD 0.27 FF 24	C-31		Well graded GRAVEL, with cobbles and boulders, subrounded, stratified, HCl not tested. (Troutdale formation) Length Recovered 2.5 ft, Length Retained 2.5 ft.		
-220				RQD 66 FF 7	C-32		Well graded conglomerate GRAVEL cemented with sand, subrounded to subangular, very dense, gray, wet, stratified, HCl not tested. (Troutdale formation). Length Recovered 5.0 ft, Length Retained 5.0 ft.		
205							End of test hole boring at 205 ft below ground elevation.		
-225							This is a summary Log of Test Boring. Soil/Rock descriptions are derived from visual field identifications and laboratory test data.		
210							Note REF = SPT Refusal		
-230									
215									
-235									
220									



LOG OF TEST BORING

Start Card S-26251

Job No. XL-2268 SR SR-5 Elevation -23.8 ft

HOLE No. CRC-RC-003

Sheet 1 of 11

Project Columbia River Crossing

Driller Kerry Cooper Lic# 2552

Site Address Vicinity of I-5 @ Columbia River

Inspector Cleo Andrews

Start August 27, 2006 Completion September 9, 2006 Well ID# _____ Equipment CME 55 with Autohammer

Station _____ Offset _____ Hole Dia 4 (inches) Method Wet Rotary

Northing 110779.40 Easting 1083663.00 Latitude _____ Longitude _____

County Clark Subsection NE1/4 of NW1/4 Section 34 Range 1 EWM Township 2

Depth (ft)	Elevation (ft)	Profile	Field SPT (N)				Blows/6" (N) and/or RQD FF	Sample Type	Sample No. (Tube No.)	Lab Tests	Description of Material	Groundwater	Instrument
			20	40	60	80							
-25.0													
5													
-30.0													
10													
-35.0													
15													
-40.0													
20													

SOILA XL-2268 SR-5 COLUMBIA RIVER CROSSING GPJ SOIL GDT 11/16/06.3:43:12.P11



Depth (ft)	Elevation (ft)	Profile	Field SPT (N)				Blows/6" (N) and/or RQD FF	Sample Type	Sample No. (Tube No.)	Lab Tests	Description of Material	Groundwater	Instrument
			20	40	60	80							
25	-45		◆	+			3 3 5 (8)	D-6	GS MC	SP-SM, MC=31% Poorly graded SAND with silt and trace of mica grains, loose, gray with trace of reddish brown sand grains, wet, homogenous, HCl not tested. Length Recovered 1.0 ft. Length Retained 1.0 ft.			
30	-50		◆	+			3 3 8 (11)	D-7	GS MC	SP-SM, MC=28% Poorly graded SAND with silt, with a layer of silty sand with ash lenses, medium dense, gray, wet, stratified, HCl not tested. Length Recovered 1.0 ft. Length Retained 1.0 ft.			
35	-55		◆	+			7 9 9 (18)	D-8	GS MC	SP-SM, MC=30% Poorly graded SAND with silt, with a layer of wood debris, medium dense, gray with trace of reddish brown sand grains, wet, homogenous, HCl not tested. Length Recovered 1.5 ft. Length Retained 1.0 ft.			
40	-60		◆				3 3 4 (7)	D-9		Poorly graded SAND with silt, with a layer of decayed wood fragments, loose, gray, wet, homogenous, HCl not tested. Length Recovered 1.0 ft. Length Retained 1.0 ft.			
45	-65		◆	+			4 8 9 (17)	D-10	GS MC	SP, MC=26% Poorly graded SAND with trace of mica grains, medium dense, gray with trace of reddish brown sand grains, wet, homogenous, HCl not tested.			

SOILA XL-2268 SR-5 COLUMBIA RIVER CROSSING GPJ SOIL GDT 11/16/06.3 43 12 P11



Depth (ft)	Elevation (ft)	Profile	Field SPT (N)				Blows/6" (N) and/or RQD FF	Sample Type	Sample No. (Tube No.)	Lab Tests	Description of Material	Groundwater	Instrument
			20	40	60	80							
-70													
50			◆										
							4 6 8 (14)	D-11			Length Recovered 1.0 ft. Length Retained 1.0 ft.		
-75													
55			◆										
							6 8 10 (18)	D-12			Poorly graded SAND with trace of mica grains, medium dense, gray with trace of reddish brown sand grains, wet, homogenous, HCl not tested. Length Recovered 1.5 ft. Length Retained 1.0 ft.		
-80													
60			◆										
							5 10 14 (24)	D-13			Poorly graded SAND, medium dense, gray, wet, homogenous, HCl not tested. Length Recovered 1.5 ft. Length Retained 1.0 ft.		
-85													
65			◆										
			◆										
							5 12 12 (24)	D-14	GS MC	SP, MC=26% Poorly graded SAND, medium dense, gray, wet, homogenous, HCl not tested. Length Recovered 1.0 ft. Length Retained 1.0 ft.			
-90													
70			◆										
							6 8	D-15			Poorly graded SAND, medium dense, gray, wet, homogenous, HCl not tested.		

SOILA XL-2268 SR-5 COLUMBIA RIVER CROSSING GPJ SOIL GDT 11/16/06.3.43.12 P11



Depth (ft)	Elevation (ft)	Profile	Field SPT (N) Moisture Content RQD	Blows/6" (N) and/or RQD FF	Sample Type Sample No. (Tube No.)	Lab Tests	Description of Material	Groundwater	Instrument
			20 40 60 80						
	-145			15 (23)			trace of reddish brown sand grains, wet, homogenous, HCl not tested. Length Recovered 1.0 ft. Length Retained 1.0 ft.		
125	-150								
	-155			9 10 6 (16)	D-24	GS MC AL HT	ML, M.C.=43%, LL=25, PL=NP Sandy SILT, with 0.5' of poorly graded sand with thin seams of organic material, medium dense, gray, wet, stratified, HCl not tested. Length Recovered 1.5 ft. Length Retained 1.5 ft.		
130	-160								
135	-165			15 16 17 (33)	D-25	GS MC	SM, MC=25% Silty SAND, with a 1 1/2 inch thick layer of fine grained silt, dense, gray, wet, stratified, HCl not tested. Length Recovered 1.5 ft. Length Retained 1.0 ft.		
140	-165								
145									

SOILA XL-2268 SR-5 COLUMBIA RIVER CROSSING GPJ SOIL GDT 11/16/05 3:43:13 P11



Depth (ft)	Elevation (ft)	Profile	Field SPT (N)				Blows/6" (N) and/or RQD FF	Sample Type	Sample No. (Tube No.)	Lab Tests	Description of Material	Groundwater	Instrument
			20	40	60	80							
-195													
175													
-200													
180													
-205													
185													
-210													
190													
-215													
195													

SOILA XL-2268 SR-5 COLUMBIA RIVER CROSSING.GPJ SOIL_GDT 11/17/06.7:18:02.A11

Length Recovered 1.5 ft. Length Retained 1.0 ft.

Poorly graded SAND, with a layer of subrounded gravel, dense, gray, wet, homogenous, HCl not tested, with one piece of 1-inch diameter subrounded gravel. Length Recovered 1.5 ft. Length Retained 1.0 ft.

SP, MC=27%
Poorly graded SAND, with a layer of seashells, wood fragments and sand, very dense, gray, wet, homogenous, trace mica grains and one piece of 1 inch diameter subrounded gravel and occasional some mica grains, HCl not tested. Length Recovered 1.5 ft. Length Retained 1.0 ft.

GP, MC=10%
Poorly graded GRAVEL with sand, subrounded, very dense, gray, wet, homogenous, trace of silt, HCl not tested. Encountered gravel at 192.5' as indicated by drilling.

11
19
23
(42)

D-29

8
25
30
(55)

D-30

GS
MC

50/4"
(REF)

D-31
C-32



Depth (ft)	Elevation (ft)	Profile	Field SPT (N)				Blows/6" (N) and/or RQD FF	Sample Type	Sample No. (Tube No.)	Lab Tests	Description of Material	Groundwater	Instrument
			20	40	60	80							
	-220							C-33		Length Recovered 0.3 ft. Length Retained 0.3 ft. Well graded GRAVEL with sand, subrounded, very dense, gray, wet, homogenous, HCl not tested.(Troutdale formation)			
								C-34		Length Recovered 2.0 ft. Length Retained 2.0 ft. Well graded GRAVEL with sand, subrounded, very dense, gray, wet, homogenous, HCl not tested.(Troutdale formation)			
200	-225							C-35		Length Recovered 2.0 ft. Length Retained 2.0 ft. Well graded GRAVEL, subrounded, very dense, gray, wet, homogenous, HCl not tested.(Troutdale formation)			
205	-230							C-36		Length Recovered 2.0 ft. Length Retained 2.0 ft. Well graded GRAVEL, subrounded, very dense, gray, wet, homogenous, HCl not tested.(Troutdale formation)			
	-235							C-37		Length Recovered 1.5 ft. Length Retained 1.5 ft. Well graded GRAVEL, with cobbles, subrounded, very dense, gray, wet, stratified, HCl not tested.(Troutdale formation)			
210	-240							C-38		Length Recovered 1.0 ft. Length Retained 1.0 ft. Well graded GRAVEL, subrounded, very dense, gray, wet, homogenous, HCl not tested.(Troutdale formation)			
215													
220													

SOILA XL-2268 SR-5 COLUMBIA RIVER CROSSING GPJ SOIL GDT 11/16/06 3:43:14 P11



Depth (ft)	Elevation (ft)	Profile	Field SPT (N) Moisture Content RQD	Blows/6" (N) and/or RQD FF	Sample Type Sample No. (Tube No.)	Lab Tests	Description of Material	Groundwater	Instrument
			20 40 60 80						
225	-245				C-39		Well graded GRAVEL, subrounded, very dense, gray, wet, homogenous, HCl not tested.(Troutdale formation) Length Recovered 0.8 ft, Length Retained 0.8 ft.		
230	-250				C-40		Well graded GRAVEL, with 2x 1 piece of conglomerate gravel, cemented with sand, subrounded, very dense, gray, wet, stratified, HCl not tested.(Troutdale formation) Length Recovered 1.5 ft. Length Retained 1.5 ft.		
235	-255				C-41		Well graded GRAVEL, with sandy silt and fine grained sand bedding, subrounded, very dense, gray, wet, homogenous. Some sandy silt and fine grained sand cemented on some gravel, HCl not tested. (Troutdale formation) Length Recovered 1.0 ft. Length Retained 1.0 ft.		
240	-260				C-42		Well graded GRAVEL, subrounded, very dense, gray, wet, homogenous, HCl not tested.(Troutdale formation) Length Recovered 1.5 ft. Length Retained 1.5 ft.		
245	-265				C-43		Well graded GRAVEL, subrounded, very dense, gray, wet, homogenous, HCl not tested.(Troutdale formation) Length Recovered 0.8 ft. Length Retained 0.8 ft.		

SOILA XL-2268 SR-5 COLUMBIA RIVER CROSSING GPJ SOIL GDT 11/17/05.7.20.16 A11



LOG OF TEST BORING

Start Card S-26251

Job No. XL-2268

SR SR-5

Elevation -23.8 ft

HOLE No. CRC-RC-003

Sheet 11 of 11

Project Columbia River Crossing

Driller Kerry Cooper

Lic# 2552

Depth (ft)	Elevation (ft)	Profile	Field SPT (N)				Blows/6" (N) and/or RQD FF	Sample Type	Sample No. (Tube No.)	Lab Tests	Description of Material	Groundwater	Instrument
			20	40	60	80							
	-270												
250													
	-275												
255													
	-280												
260													
	-285												
265													
	-290												
270													

End of test hole boring at 244 ft below ground elevation.
This is a summary Log of Test Boring.

Soil/Rock descriptions are derived from visual field
identifications and laboratory test data.

Note REF = SPT Refusal

SOILA XL-2268 SR-5 COLUMBIA RIVER CROSSING GPJ SOIL GDT 11/16/05.3.43.14 P11

APPENDIX C – LABORATORY TEST RESULTS

LABORATORY TESTING

Laboratory testing was performed on selected samples from the field exploration program, including moisture contents, grain size analyses and plasticity characteristics. The tests were done in general accordance with AASHTO guide specifications. The results of these tests are presented on the boring logs in Appendix B and in this appendix. After the testing was complete, the samples were classified in general accordance with the Unified Soil Classification System (USCS).

Depth (ft)	Depth (m)	Sample No.	USCS	Color	Description	MC%	LL	PL	PI
● 9.0	2.74	D-2	SP	See Boring Log	POORLY GRADED SAND	34			
⊠ 14.0	4.27	D-3	SP	See Boring Log	POORLY GRADED SAND	27			
▲ 24.5	7.47	D-5	SP	See Boring Log	POORLY GRADED SAND	26			
★ 30.0	9.14	D-6	SP	See Boring Log	POORLY GRADED SAND	31			
⊙ 40.0	12.19	D-8	SP	See Boring Log	POORLY GRADED SAND	29			

GRADATION FRACTIONS

%Gravel	%Sand	%Fines	Cc	Cu
● 0.1	95.8	4.1	1.3	2.9
⊠ 0.6	96.2	3.2	1.1	1.9
▲ 1.4	95.7	2.9	0.8	3.8
★ 0.2	96.5	3.3	1.1	2.7
⊙ 0.3	97.5	2.2	0.7	2.9

GRADATION VALUES

D60	D50	D30	D20	D10
● 0.304	0.27	0.20	0.17	0.106
⊠ 0.331	0.30	0.25	0.21	0.176
▲ 0.623	0.44	0.29	0.24	0.164
★ 0.355	0.31	0.23	0.19	0.132
⊙ 0.707	0.54	0.35	0.30	0.245

US Sieve Opening In Inches | US Sieve Numbers | Hydrometer Analysis

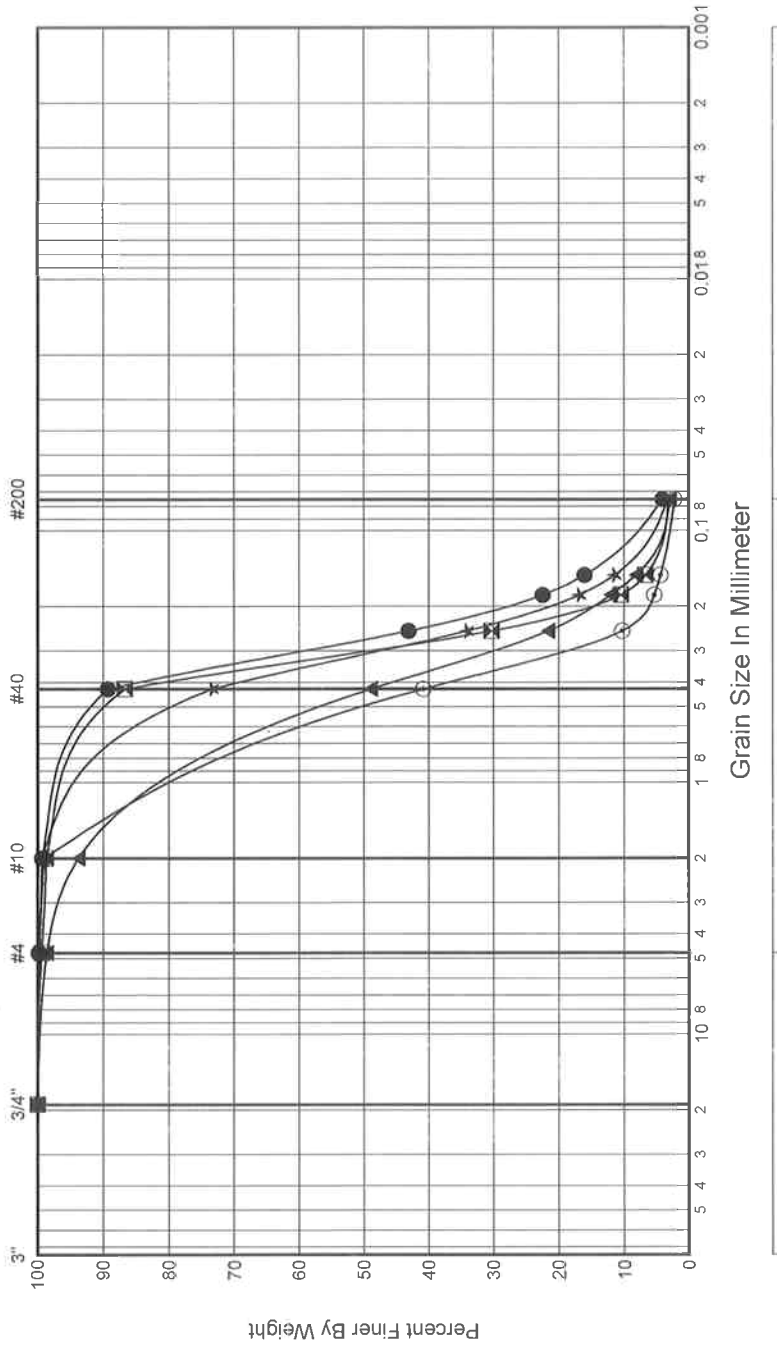

Gravel	Sand			Silt and Clay
	Coarse	Medium	Fine	



Laboratory Summary

Date **November 16, 2006**
Sheet **2** of **2**

Job No. **XL-2268**
Hole No. **CRC-RC-001**
Project **Columbia River Crossing**

Depth (ft)	Depth (m)	Sample No.	USCS	Color	Description	MC%	LL	PL	PI
● 54.5	16.61	D-11	SP	See Boring Log	POORLY GRADED SAND	24			
☒ 68.5	20.88	D-14	SP	See Boring Log	POORLY GRADED SAND	24			
▲ 73.0	22.25	D-15	SP	See Boring Log	POORLY GRADED SAND	29			

GRADATION FRACTIONS

	%Gravel	%Sand	%Fines	Cc	Cu
●	0.1	95.7	4.2	0.8	3.8
☒	1.1	95.3	3.6	0.8	3.9
▲	0.0	96.7	3.3	1.1	1.8

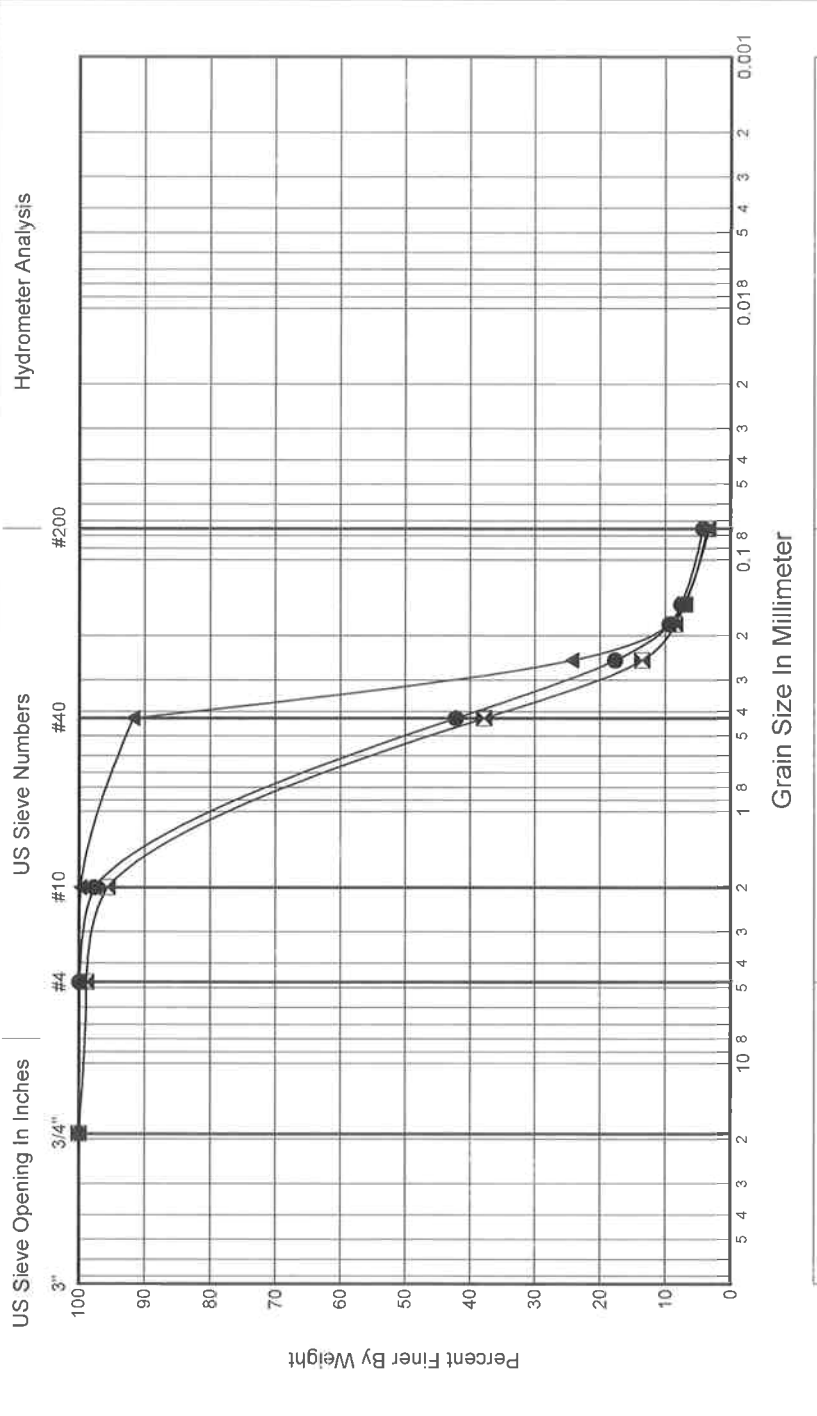

GRADATION VALUES

	D60	D50	D30	D20	D10
●	0.698	0.53	0.33	0.26	0.185
☒	0.769	0.59	0.36	0.29	0.198
▲	0.331	0.31	0.26	0.23	0.182



Laboratory Summary

Date **November 16, 2006**
Sheet **1** of **3**

Job No. **XL-2268**
Hole No. **CRC-RC-002**
Project **Columbia River Crossing**

Depth (ft)	Depth (m)	Sample No.	USCS	Color	Description	MC%	LL	PL	PI
8.0	2.44	D-2	SP	See Boring Log	POORLY GRADED SAND	25			
14.5	4.42	D-3	SP	See Boring Log	POORLY GRADED SAND	24			
24.5	7.47	D-5	SP	See Boring Log	POORLY GRADED SAND	24			
29.5	8.99	D-6	SP	See Boring Log	POORLY GRADED SAND	29			
50.0	15.24	D-10	SP	See Boring Log	POORLY GRADED SAND	26			

GRADATION FRACTIONS

%Gravel	%Sand	%Fines	Cc	Cu
0.1	97.9	2.0	0.8	3.7
3.4	95.5	1.1	1.0	1.9
2.7	94.6	2.7	0.8	3.5
0.0	97.0	3.0	1.0	1.8
0.2	95.2	4.6	1.3	2.6

GRADATION VALUES

D60	D50	D30	D20	D10
0.732	0.56	0.34	0.27	0.199
0.419	0.37	0.30	0.26	0.216
0.548	0.40	0.27	0.21	0.157
0.305	0.28	0.23	0.20	0.166
0.269	0.24	0.19	0.16	0.104

Hydrometer Analysis

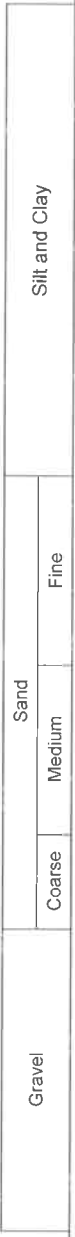
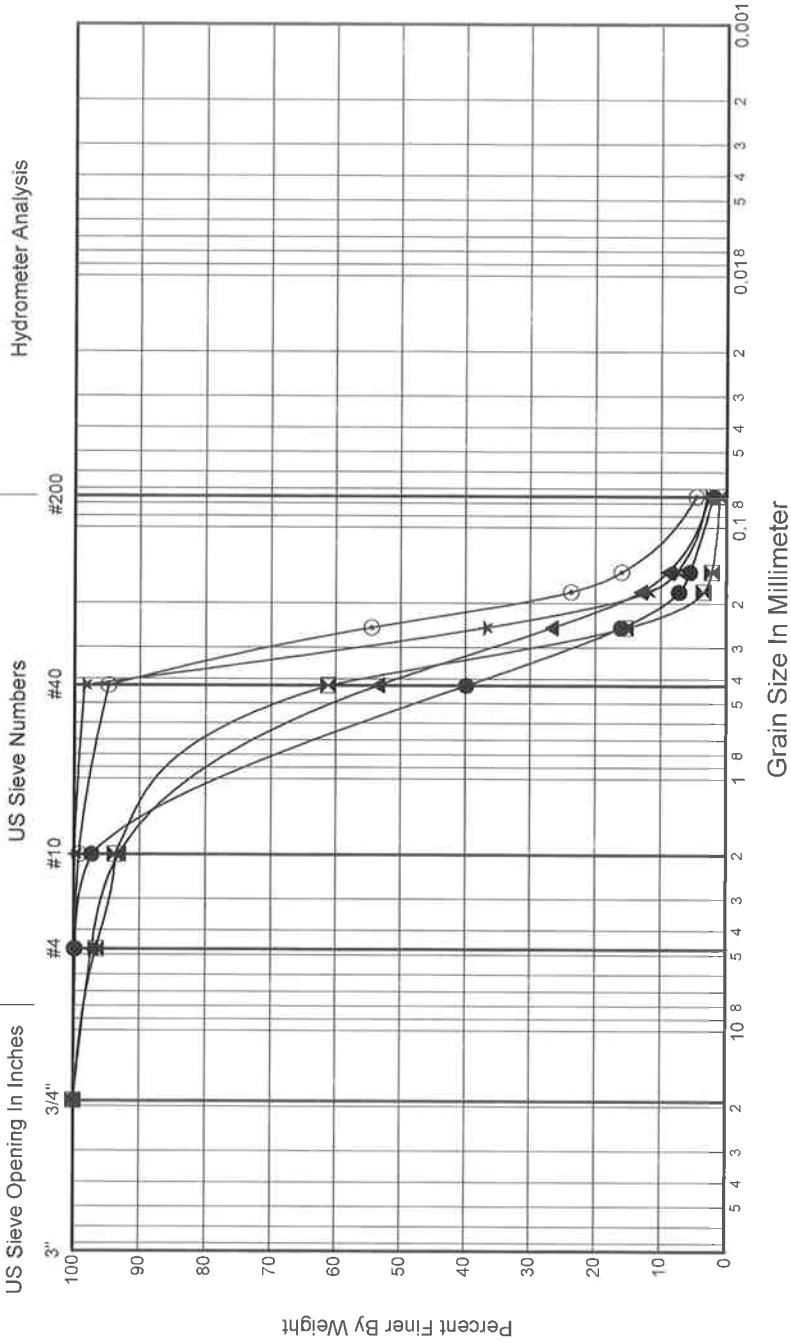

Depth (ft)	Depth (m)	Sample No.	USCS	Color	Description	MC%	LL	PL	PI
65.0	19.81	D-13	SP-SM	See Boring Log	POORLY GRADED SAND with SILT	24			
81.0	24.69	D-16	SP	See Boring Log	POORLY GRADED SAND	25			
91.0	27.74	D-18	SP-SM	See Boring Log	POORLY GRADED SAND with SILT	28			
95.5	29.11	D-19	SP	See Boring Log	POORLY GRADED SAND	28			
100.0	30.48	D-20	SP-SM	See Boring Log	POORLY GRADED SAND with SILT	30			

GRADATION FRACTIONS

%Gravel	%Sand	%Fines	Cc	Cu
0.3	92.2	7.5	1.7	3.2
0.0	95.3	4.7	1.4	2.5
0.0	94.5	5.5	1.3	2.7
0.0	96.5	3.5	1.0	1.9
0.0	91.6	8.4	1.2	2.6

GRADATION VALUES

D60	D50	D30	D20	D10
0.337	0.30	0.24	0.20	0.104
0.324	0.30	0.24	0.20	0.128
0.326	0.29	0.23	0.19	0.120
0.295	0.27	0.22	0.19	0.152
0.204	0.19	0.14	0.10	0.078

Hydrometer Analysis

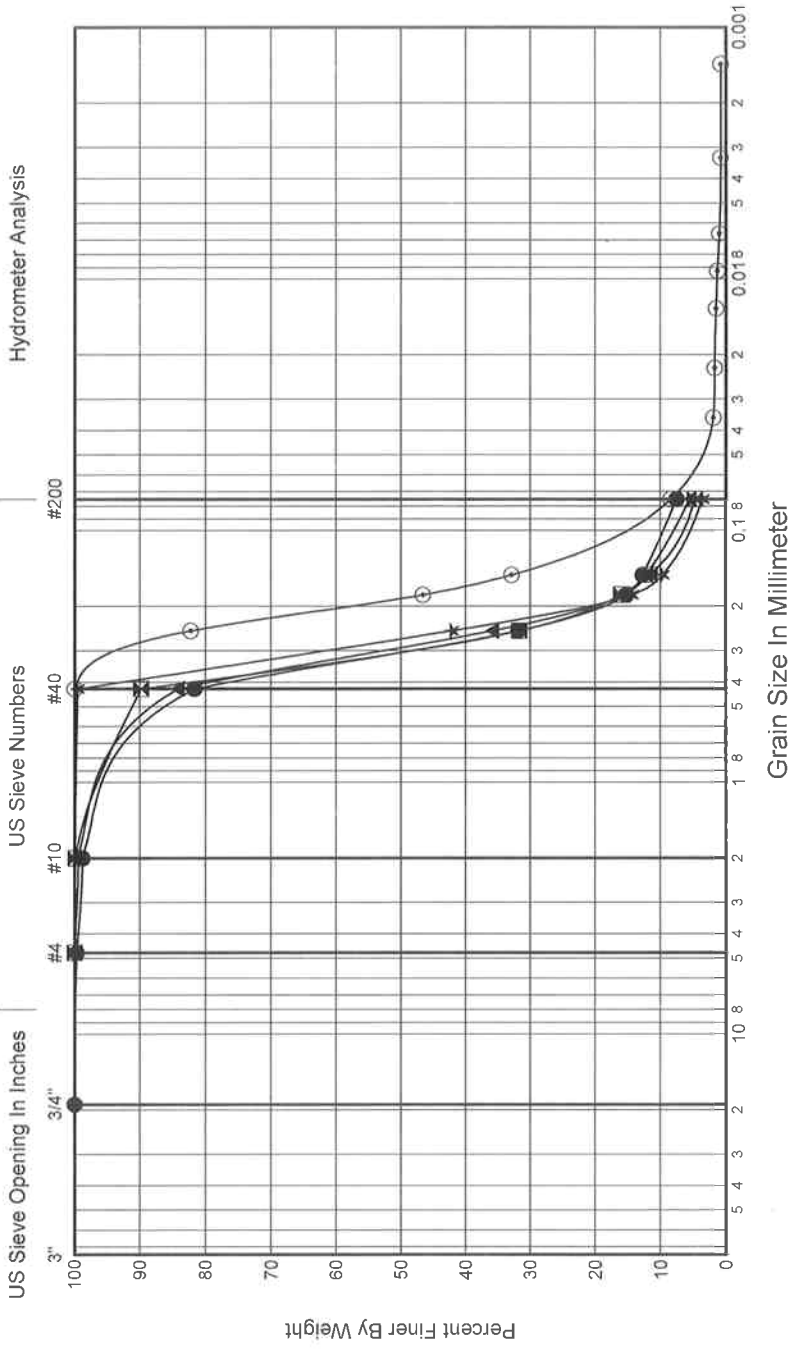

Gravel	Sand			Silt and Clay
	Coarse	Medium	Fine	

Depth (ft)	Depth (m)	Sample No.	USCS	Color	Description	MC%	LL	PL	PI
● 109.0	33.22	D-21	SP	See Boring Log	POORLY GRADED SAND	30			
☒ 124.5	37.95	D-23	SP-SM	See Boring Log	POORLY GRADED SAND with SILT	25			
▲ 154.0	46.94	D-26	SP	See Boring Log	POORLY GRADED SAND	24			
★ 175.0	53.34	D-28	SP-SM	See Boring Log	POORLY GRADED SAND with SILT and shells	22			
○ 195.5	59.59	D-30	SP-SM	See Boring Log	POORLY GRADED SAND with SILT and wood chunks	29			

GRADATION FRACTIONS

	%Gravel	%Sand	%Fines	Cc	Cu
●	0.0	95.1	4.9	1.5	2.3
☒	0.0	92.6	7.4	1.6	2.7
▲	0.0	95.2	4.8	1.3	2.4
★	2.8	91.5	5.7	1.4	2.6
○	0.4	94.2	5.4	1.2	3.9

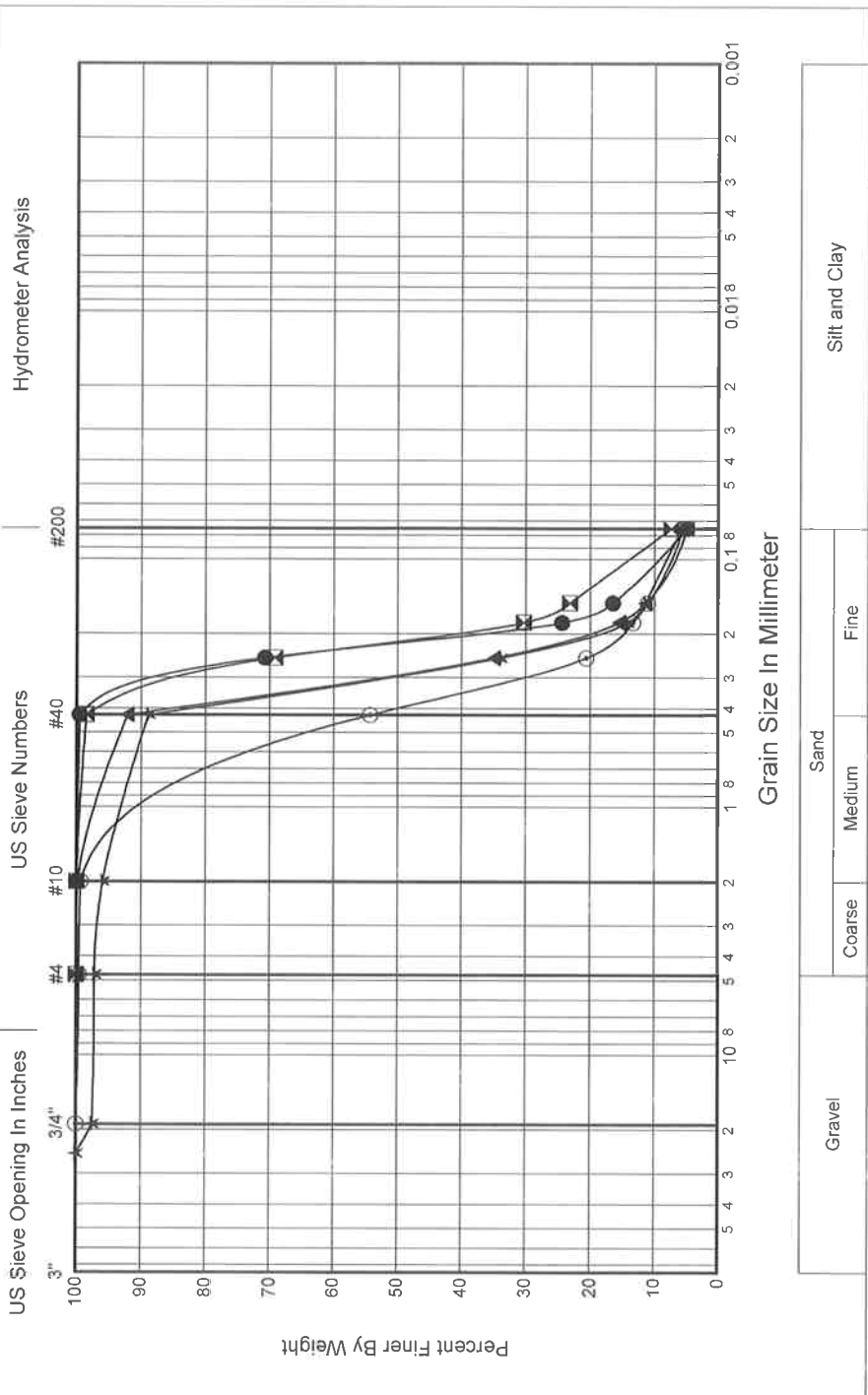

Depth (ft)	Depth (m)	Sample No.	USCS	Color	Description	MC%	LL	PL	PI
●	8.0	D-2	SP	See Boring Log	POORLY GRADED SAND	26			
☒	13.5	D-4	SP	See Boring Log	POORLY GRADED SAND	23			
▲	23.5	D-6	SP-SM	See Boring Log	POORLY GRADED SAND with SILT	31			
★	28.5	D-7	SP-SM	See Boring Log	POORLY GRADED SAND with SILT	28			
◎	33.5	D-8	SP-SM	See Boring Log	POORLY GRADED SAND with SILT and wood chunks	30			

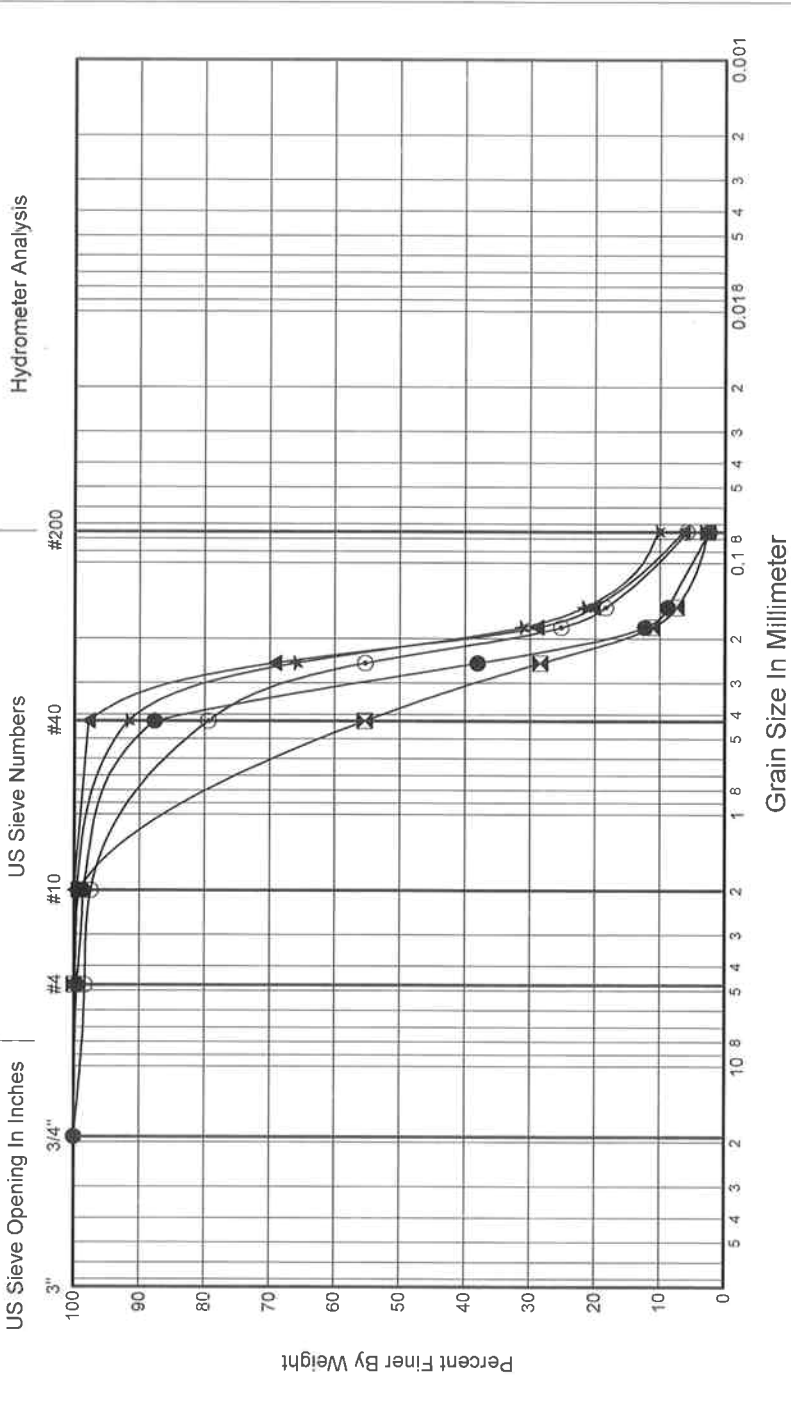

GRADATION FRACTIONS					
%Gravel	%Sand	%Fines	Cc	Cu	
●	0.4	97.2	2.4	1.0	2.0
☒	0.0	97.4	2.6	0.8	2.9
▲	0.0	93.6	6.4	1.6	2.6
★	0.2	89.5	10.3	1.8	3.2
◎	1.7	92.5	5.8	1.4	2.9

GRADATION VALUES				
D60	D50	D30	D20	D10
●	0.316	0.28	0.23	0.20
☒	0.500	0.38	0.26	0.21
▲	0.232	0.21	0.18	0.15
★	0.236	0.21	0.18	0.14
◎	0.277	0.24	0.19	0.16



Job No. **XL-2268**

Date **November 17, 2006**

Hole No. **CRC-RC-003**

Sheet **2** of **4**

Project **Columbia River Crossing**

Laboratory Summary



Washington State
Department of Transportation

Depth (ft)	Depth (m)	Sample No.	USCS	Color	Description	MC%	LL	PL	PI
● 43.5	13.26	D-10	SP	See Boring Log	POORLY GRADED SAND	26			
☒ 64.0	19.51	D-14	SP	See Boring Log	POORLY GRADED SAND	26			
▲ 78.0	23.77	D-17	SP-SM	See Boring Log	POORLY GRADED SAND with SILT	28			
★ 93.5	28.50	D-20	SP-SM	See Boring Log	POORLY GRADED SAND with SILT	25			
◎ 98.5	30.02	D-21	SP	See Boring Log	POORLY GRADED SAND	25			

GRADATION FRACTIONS

	%Gravel	%Sand	%Fines	Cc	Cu
●	0.9	95.4	3.7	1.1	2.1
☒	0.0	95.2	4.8	1.2	2.2
▲	0.3	90.9	8.8	1.6	2.7
★	0.0	93.6	6.4	1.4	2.7
◎	0.3	95.0	4.6	1.1	2.2

GRADATION VALUES

	D60	D50	D30	D20	D10
●	0.282	0.25	0.21	0.19	0.131
☒	0.297	0.27	0.21	0.19	0.132
▲	0.214	0.20	0.16	0.12	0.079
★	0.289	0.26	0.20	0.18	0.106
◎	0.304	0.27	0.22	0.19	0.137

US Sieve Opening In Inches | US Sieve Numbers | Hydrometer Analysis

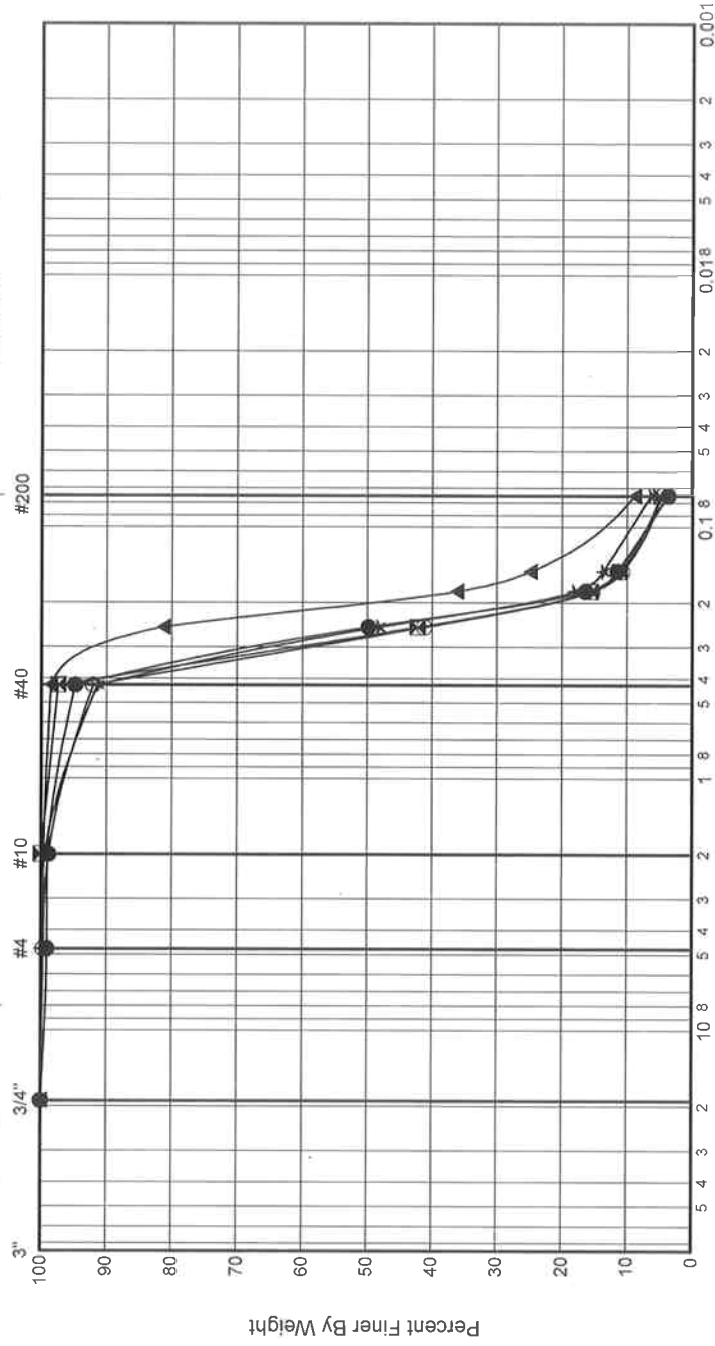

Grain Size In Millimeter

Gravel	Sand		Silt and Clay
	Coarse	Fine	

Job No. **XL-2268**
Hole No. **CRC-RC-003**
Project **Columbia River Crossing**

Date **November 17, 2006**
Sheet **3 of 4**

Laboratory Summary



Washington State
Department of Transportation

Depth (ft)	Depth (m)	Sample No.	USCS	Color	Description	MC%	LL	PL	PI
● 119.0	36.27	D-23	SP	See Boring Log	POORLY GRADED SAND	25			
☒ 129.0	39.32	D-24	ML	See Boring Log	SANDY SILT	43	25	NP	NP
▲ 138.5	42.21	D-25	SM	See Boring Log	SILTY SAND	25			
★ 148.5	45.26	D-26	SP	See Boring Log	POORLY GRADED SAND	24			
◎ 168.5	51.36	D-28	SP-SM	See Boring Log	POORLY GRADED SAND with SILT	22			

GRADATION FRACTIONS

%Gravel	%Sand	%Fines	Cc	Cu
● 0.7	94.8	4.4	1.1	2.3
☒ 0.0	40.6	59.4	0.9	2.1
▲ 2.4	84.0	13.6		
★ 0.0	96.6	3.4	1.1	1.9
◎ 11.5	82.9	5.5	1.2	2.5

GRADATION VALUES

D60	D50	D30	D20	D10
● 0.340	0.30	0.23	0.20	0.146
☒ 0.077	0.07	0.05	0.04	0.037
▲ 0.270	0.24	0.19	0.13	
★ 0.311	0.29	0.23	0.20	0.166
◎ 0.370	0.33	0.26	0.21	0.149

US Sieve Opening In Inches | US Sieve Numbers | Hydrometer Analysis

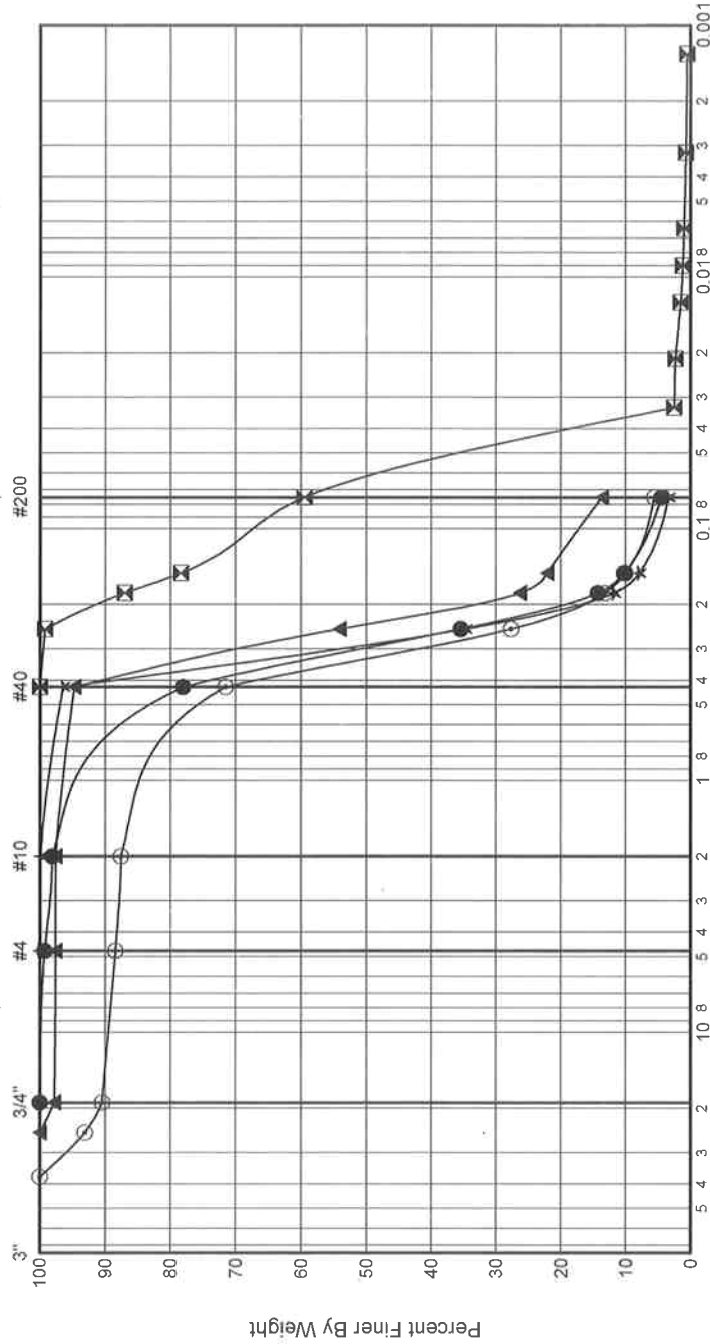

Grain Size In Millimeter

Gravel	Sand		Silt and Clay
	Coarse	Fine	

Laboratory Summary

Job No. **XL-2268**
Hole No. **CRC-RC-003**
Project **Columbia River Crossing**

Depth (ft)	Depth (m)	Sample No.	USCS	Color	Description	MC%	LL	PL	PI
● 189.0	57.61	D-30	SP	See Boring Log	POORLY GRADED SAND	27			
☒ 193.0	58.83	D-31	GP	See Boring Log	POORLY GRADED GRAVEL with SAND	10			

GRADATION FRACTIONS

%Gravel	%Sand	%Fines	Cc	Cu
● 6.2	89.6	4.2	1.1	1.9
☒ 48.4	47.2	4.4	0.3	39.6

GRADATION VALUES

D60	D50	D30	D20	D10
● 0.366	0.34	0.28	0.26	0.189
☒ 8.316	4.20	0.71	0.35	0.210

Hydrometer Analysis

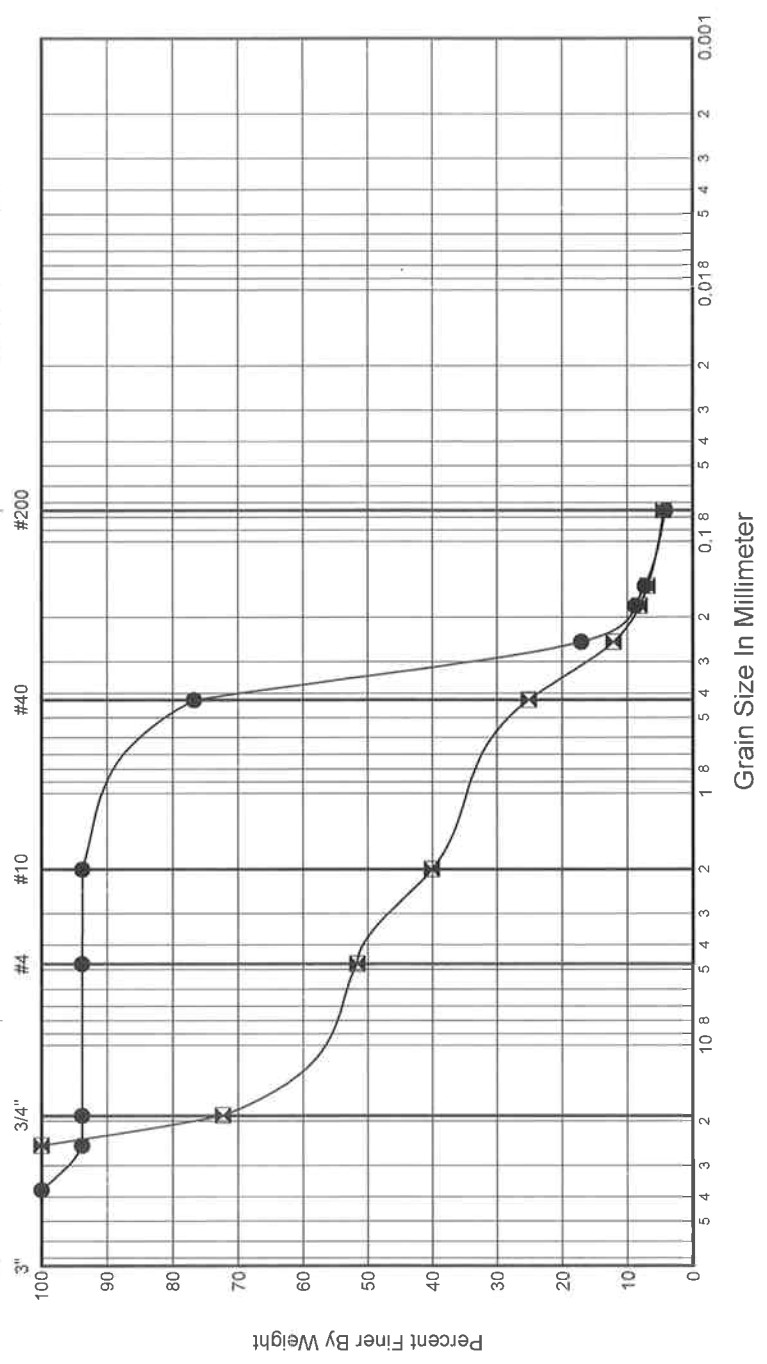

Gravel	Sand			Silt and Clay
	Coarse	Medium	Fine	

APPENDIX D - AXIAL CAPACITY CHARTS FOR DRILLED SHAFTS

Unfactored Skin Friction CRC-RC-001, 10-Foot Diameter Shaft

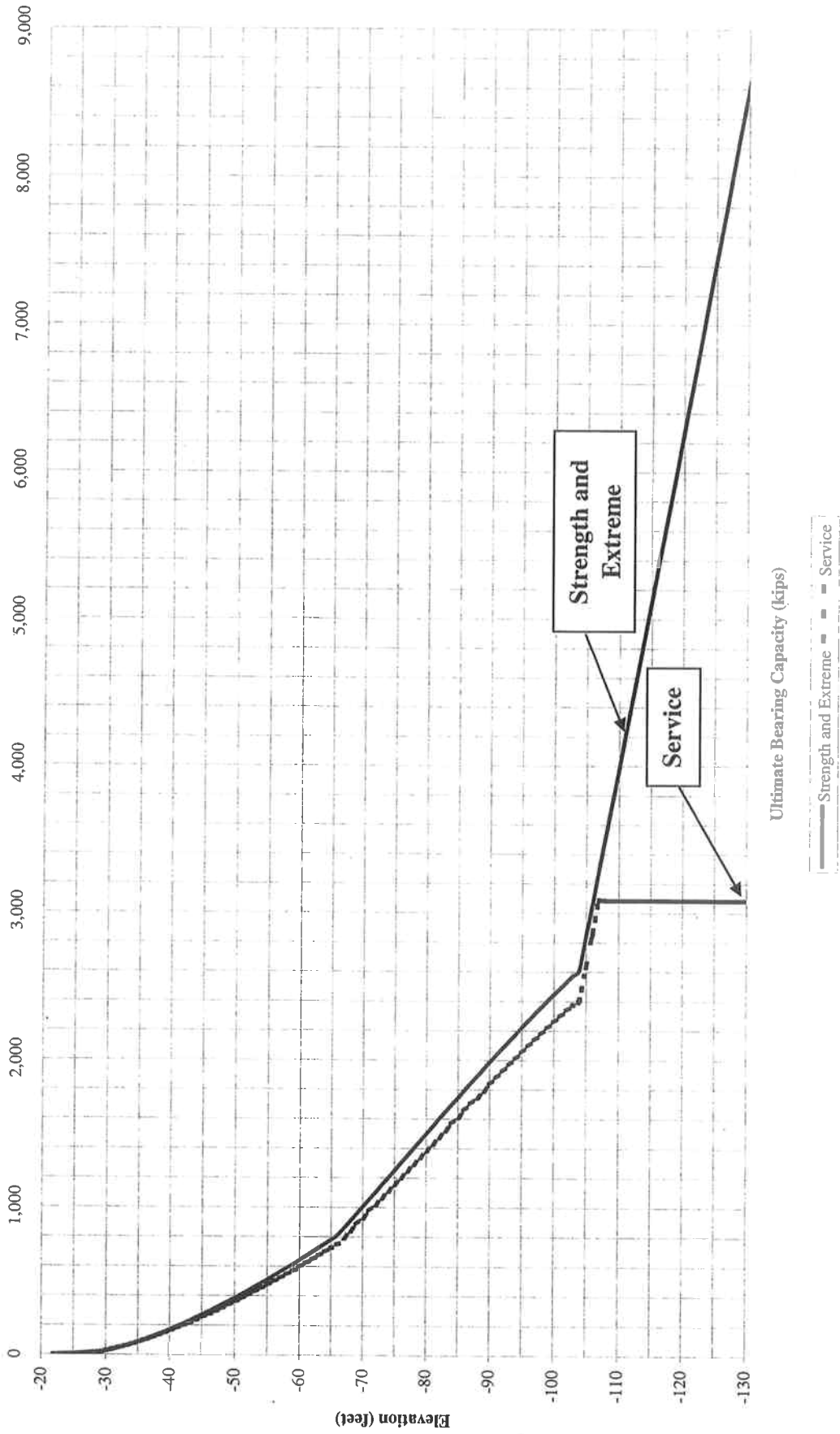

Unfactored End Bearing CRC-RC-001, 10 Foot Diameter Shaft

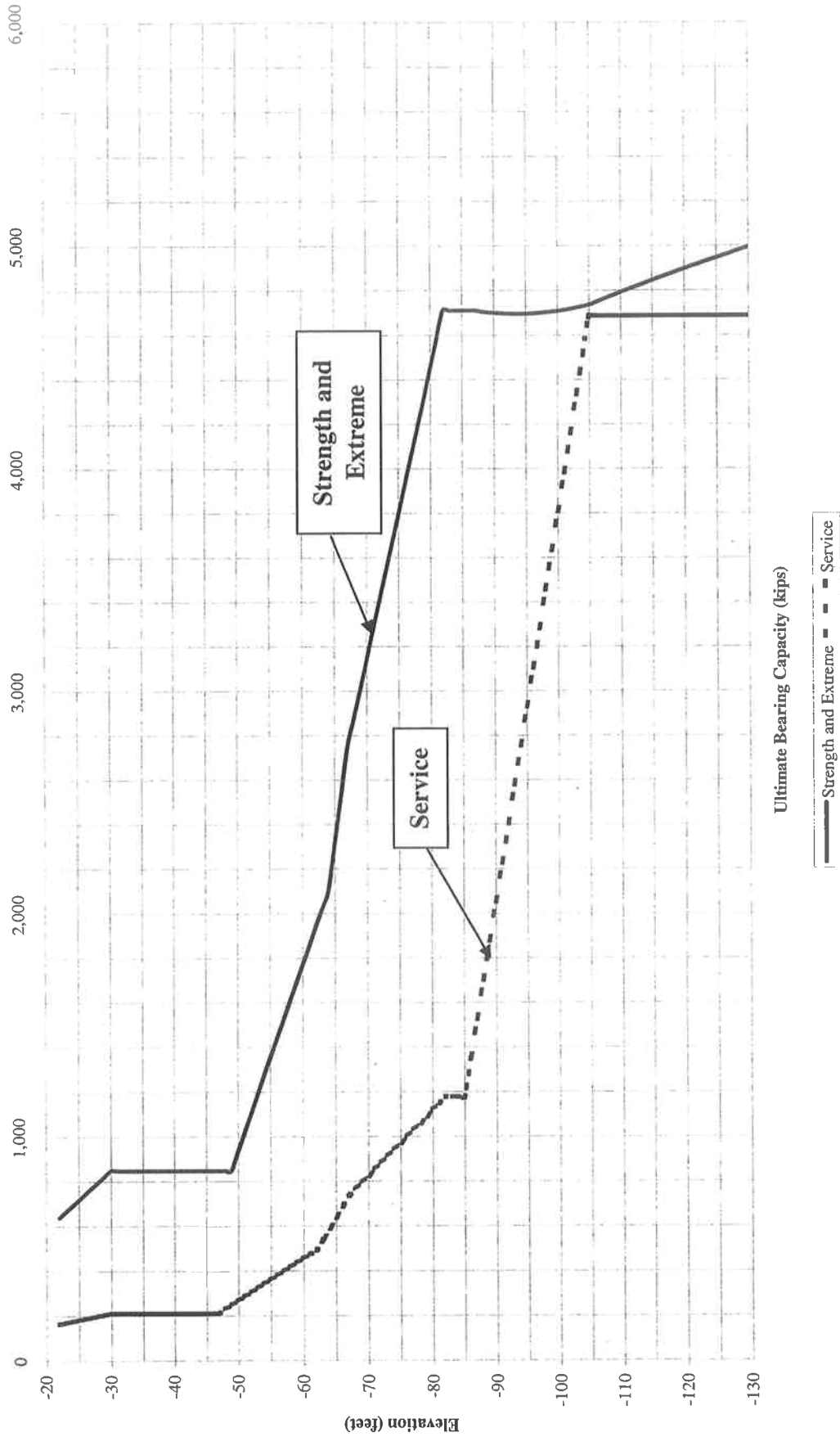

Unfactored Skin Friction CRC-RC-001, 12-Foot Diameter Shaft

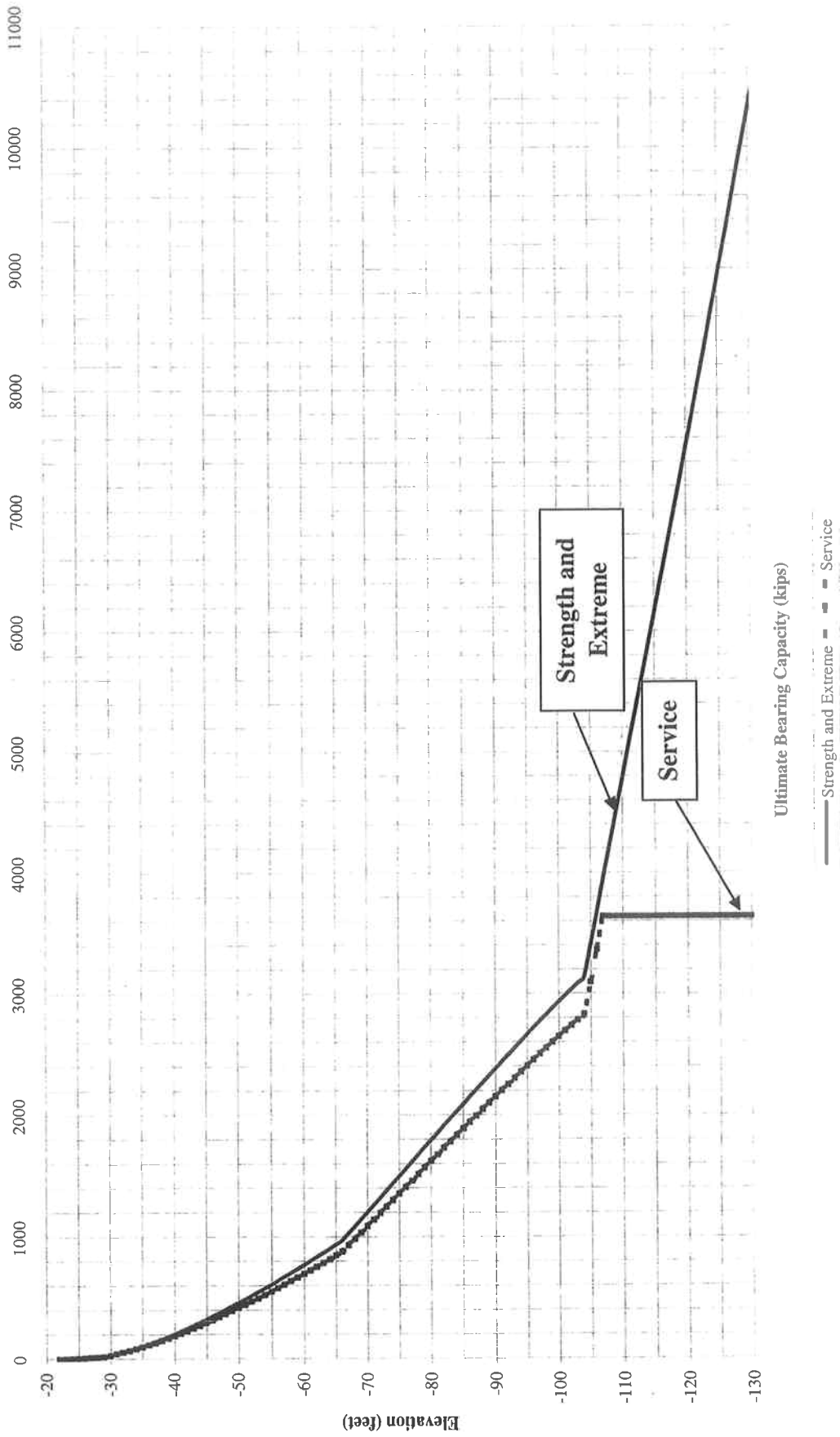

Unfactored End Bearing CRC-RC-001, 12-Foot Diameter Shaft

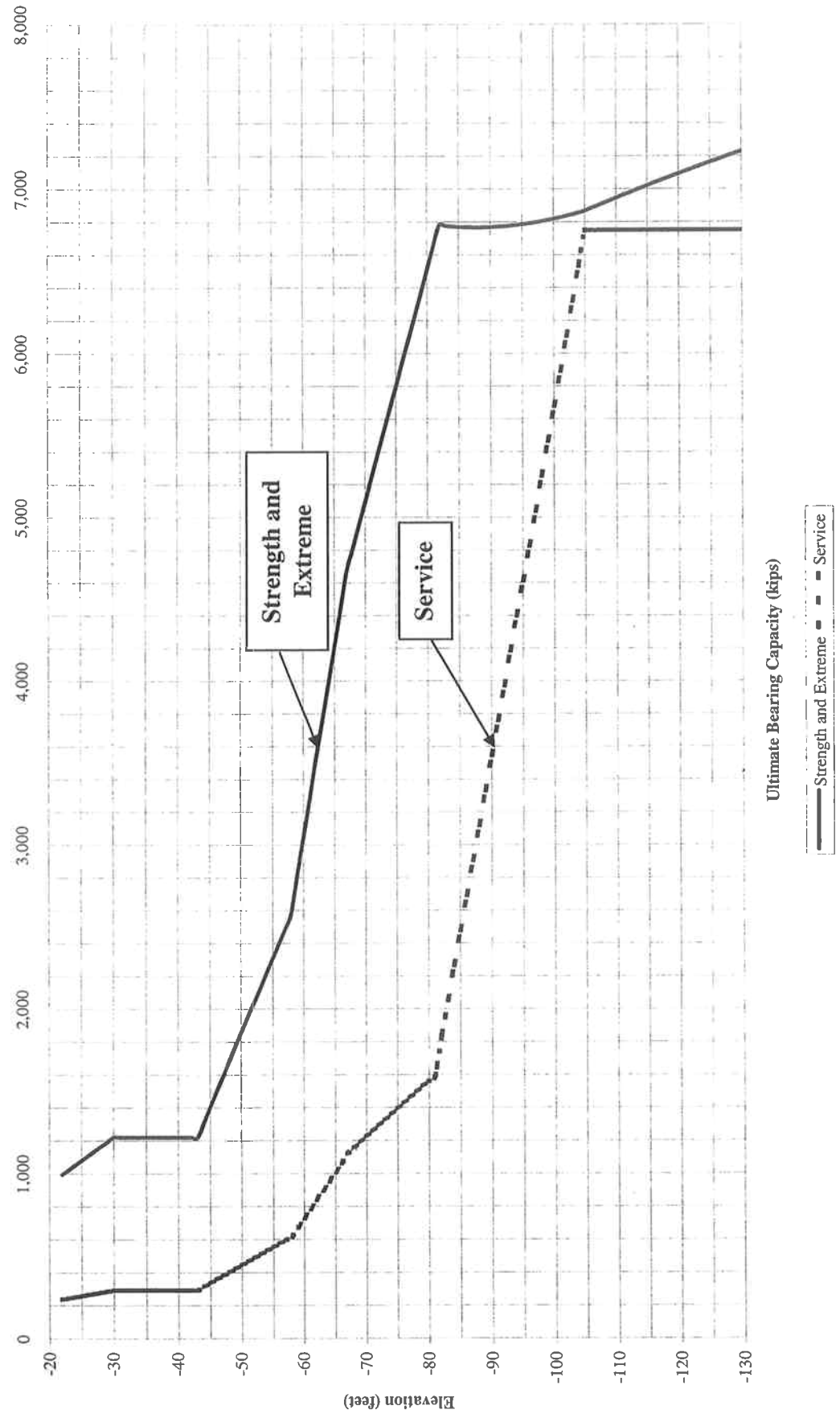

Unfactored Skin Friction CRC-RC-002, 10-Foot Diameter Shaft

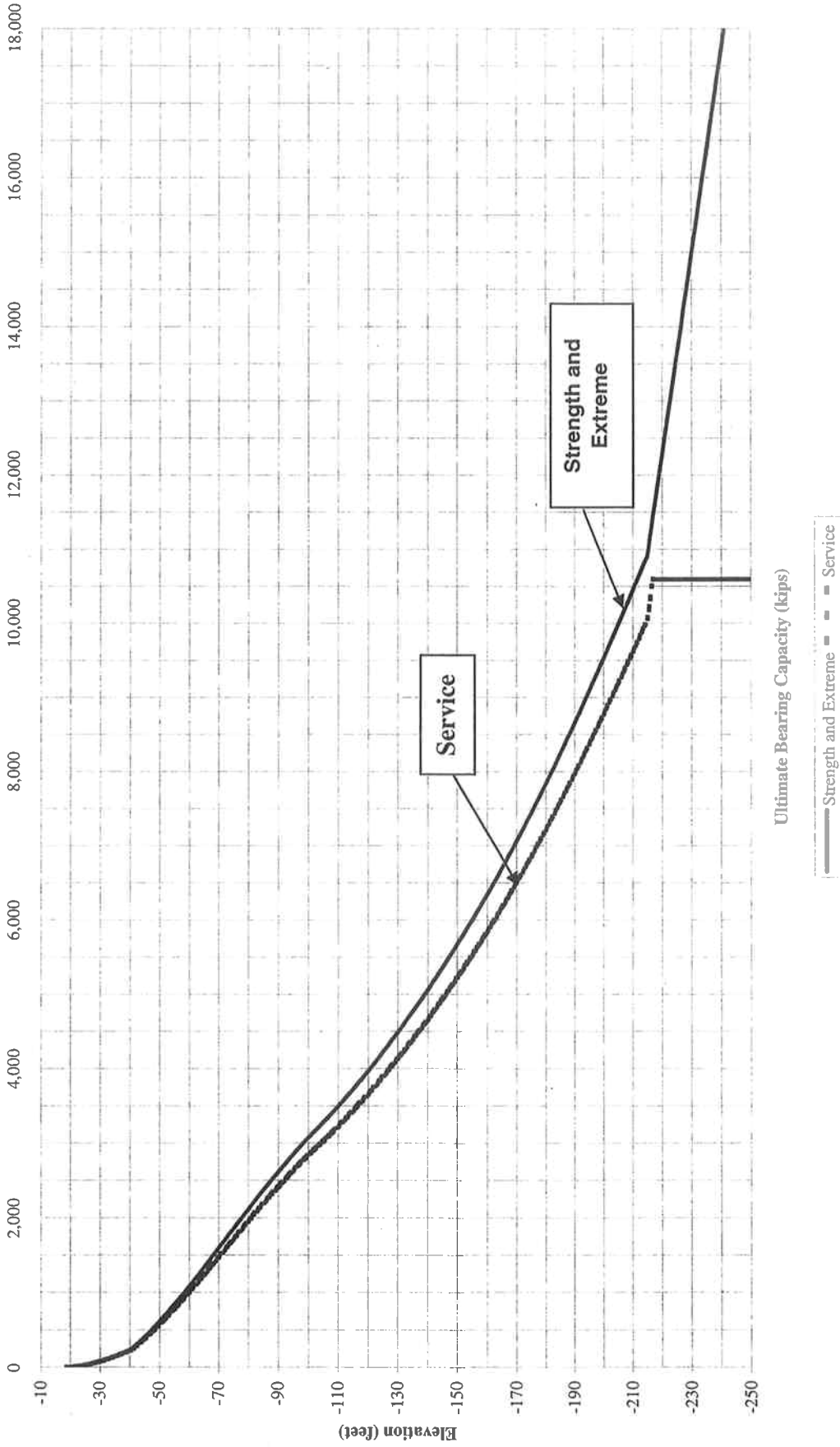

Unfactored End Bearing CRC-RC-002, 10-Foot Diameter Shaft

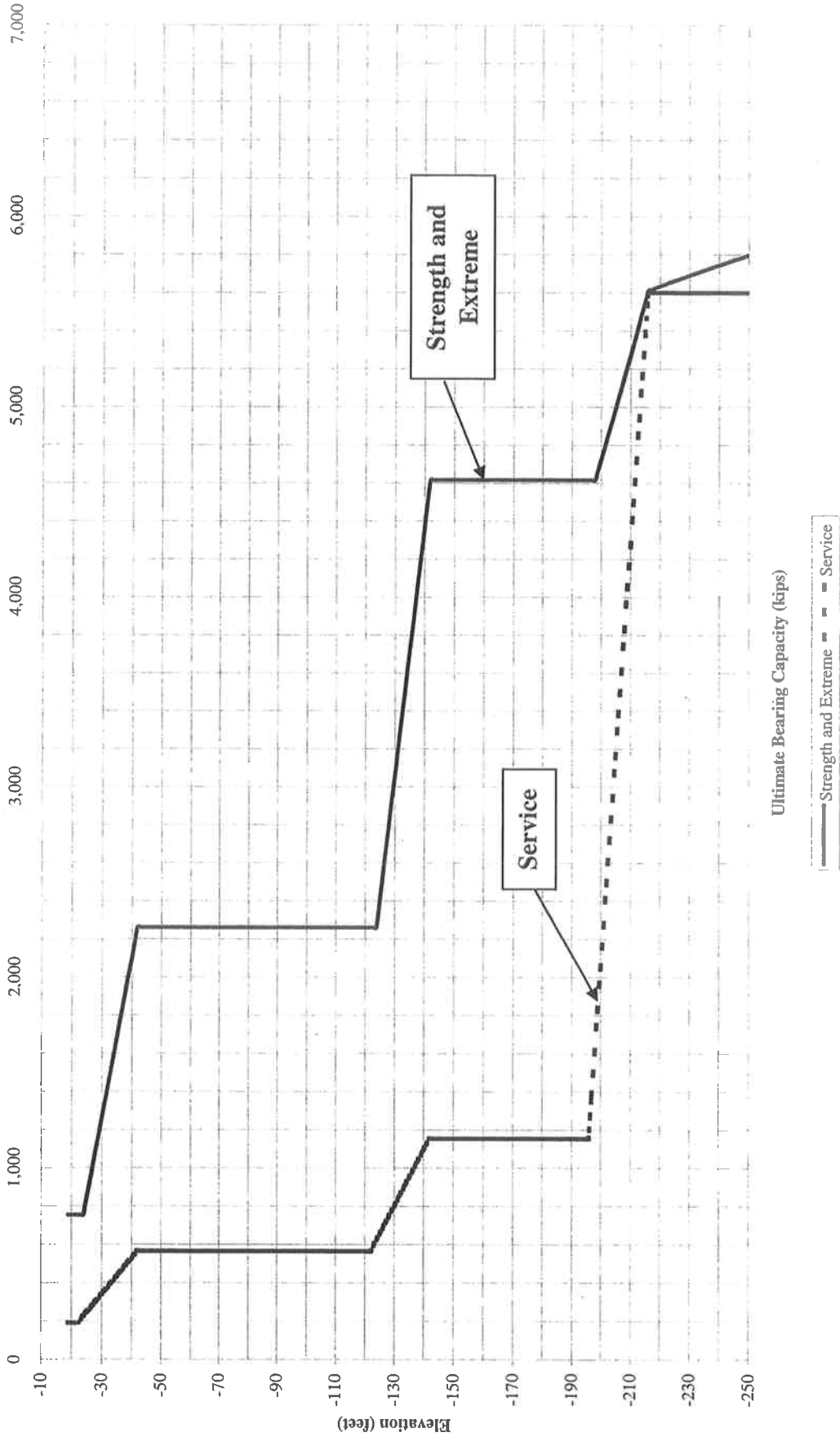

Unfactored Skin Friction CRC-RC-002, 12-Foot Diameter Shaft

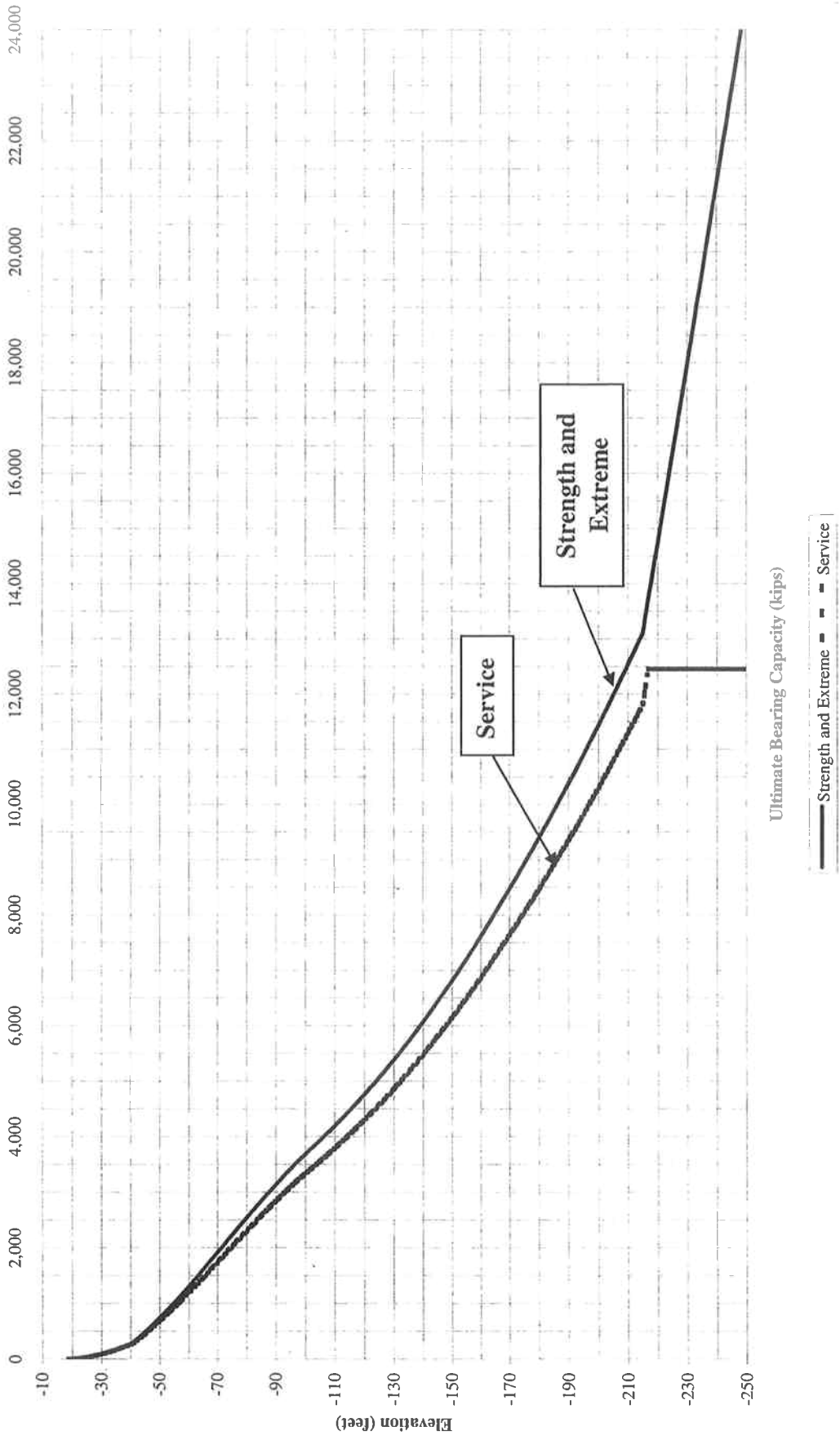

Unfactored End Bearing CRC-RC-002, 12-Foot Diameter Shaft

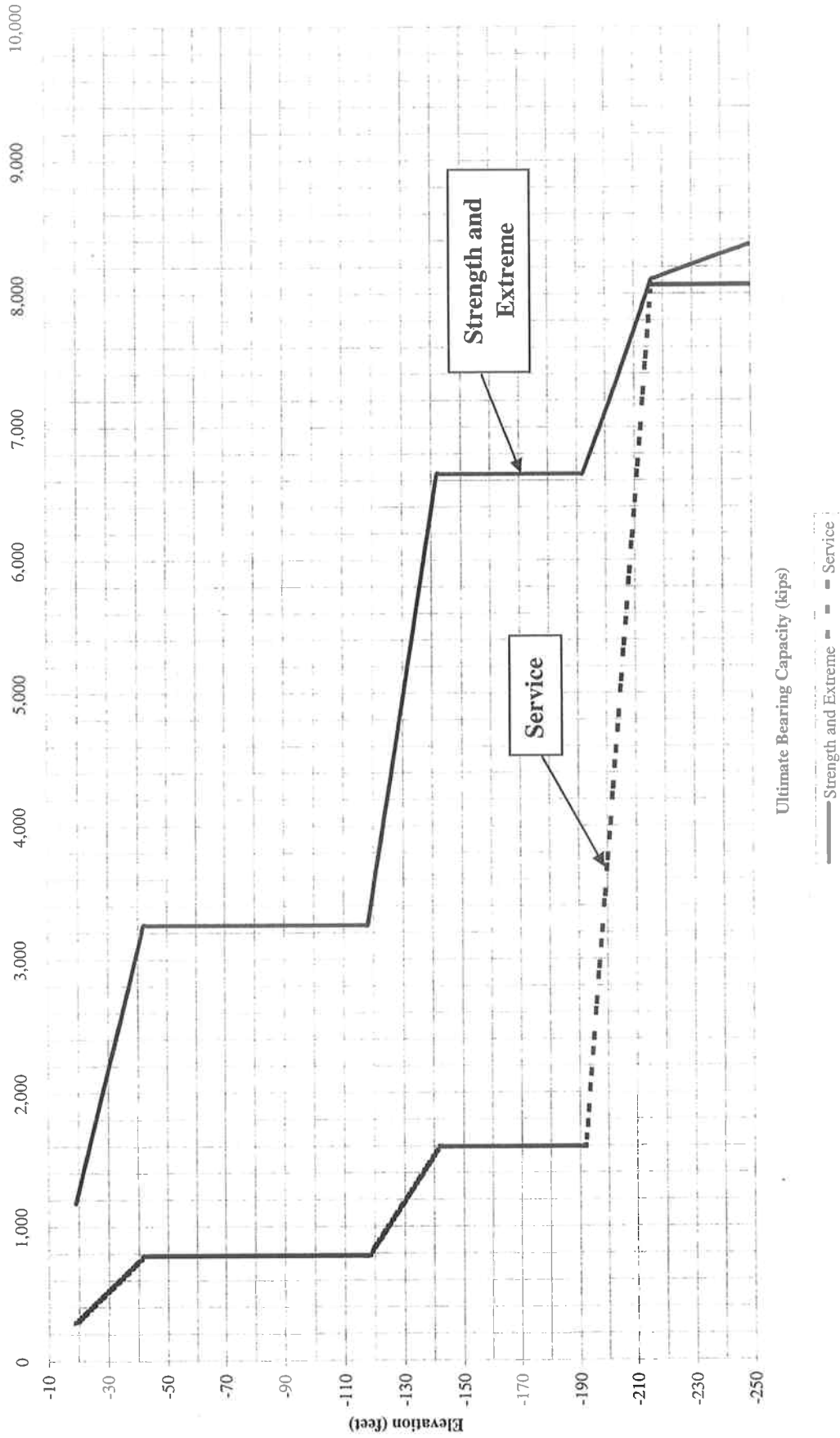

Unfactored Skin Friction CRC-RC-003, 10-Foot Diameter Shaft

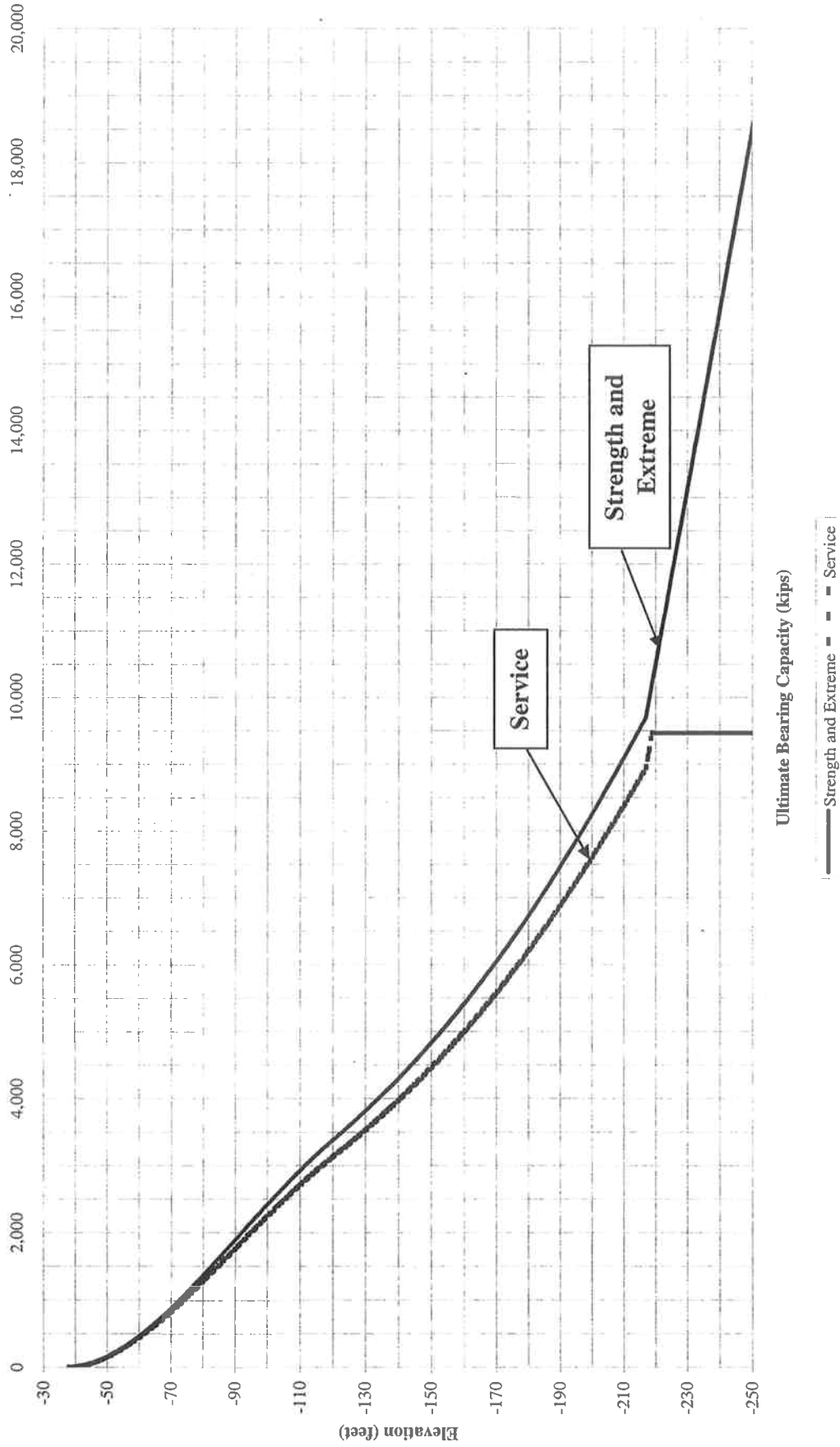

Unfactored End Bearing CRC-RC-003, 10-Foot Diameter Shaft

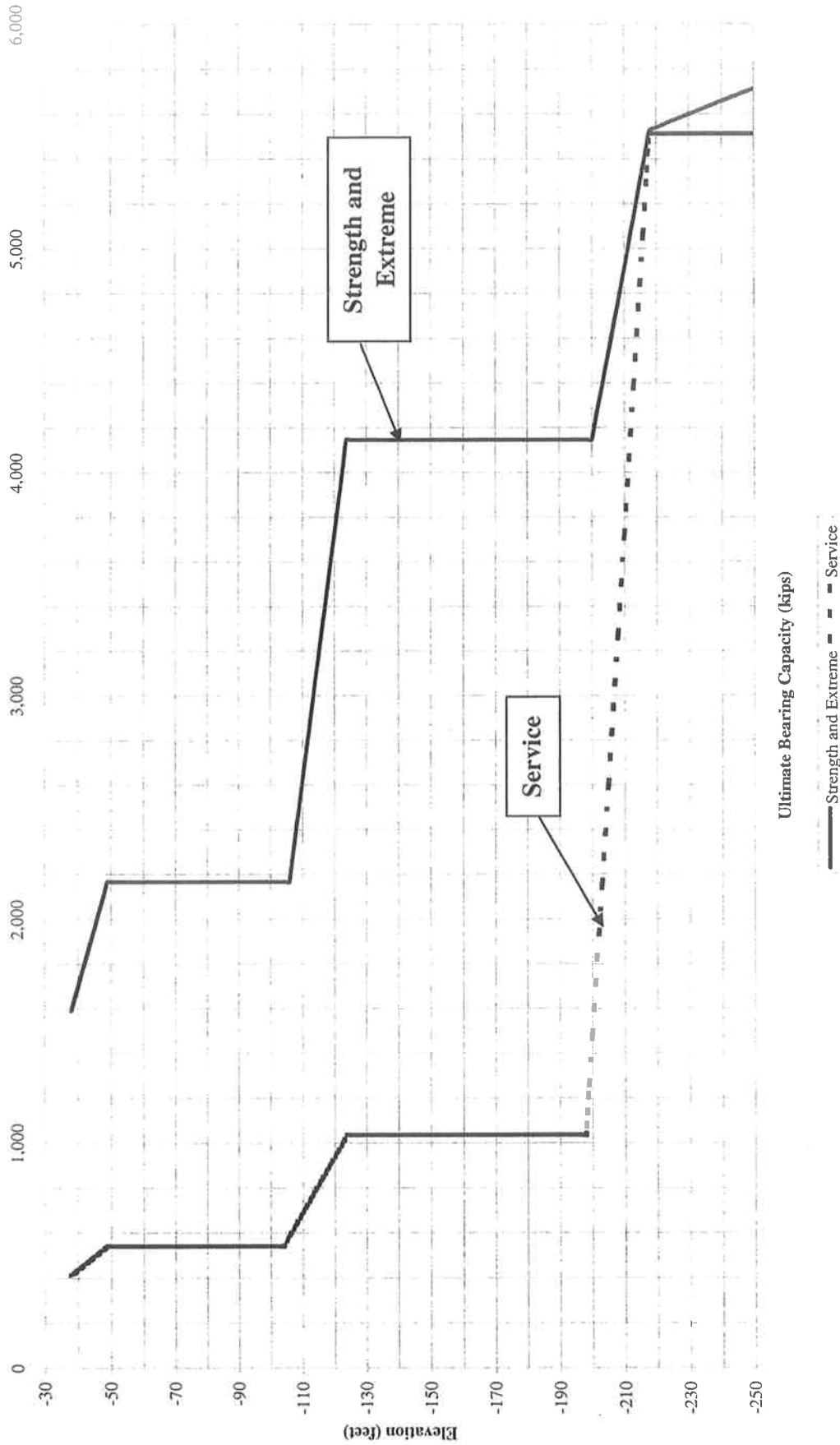

Unfactored Skin Friction CRC-RC-003, 12-Foot Diameter Shaft

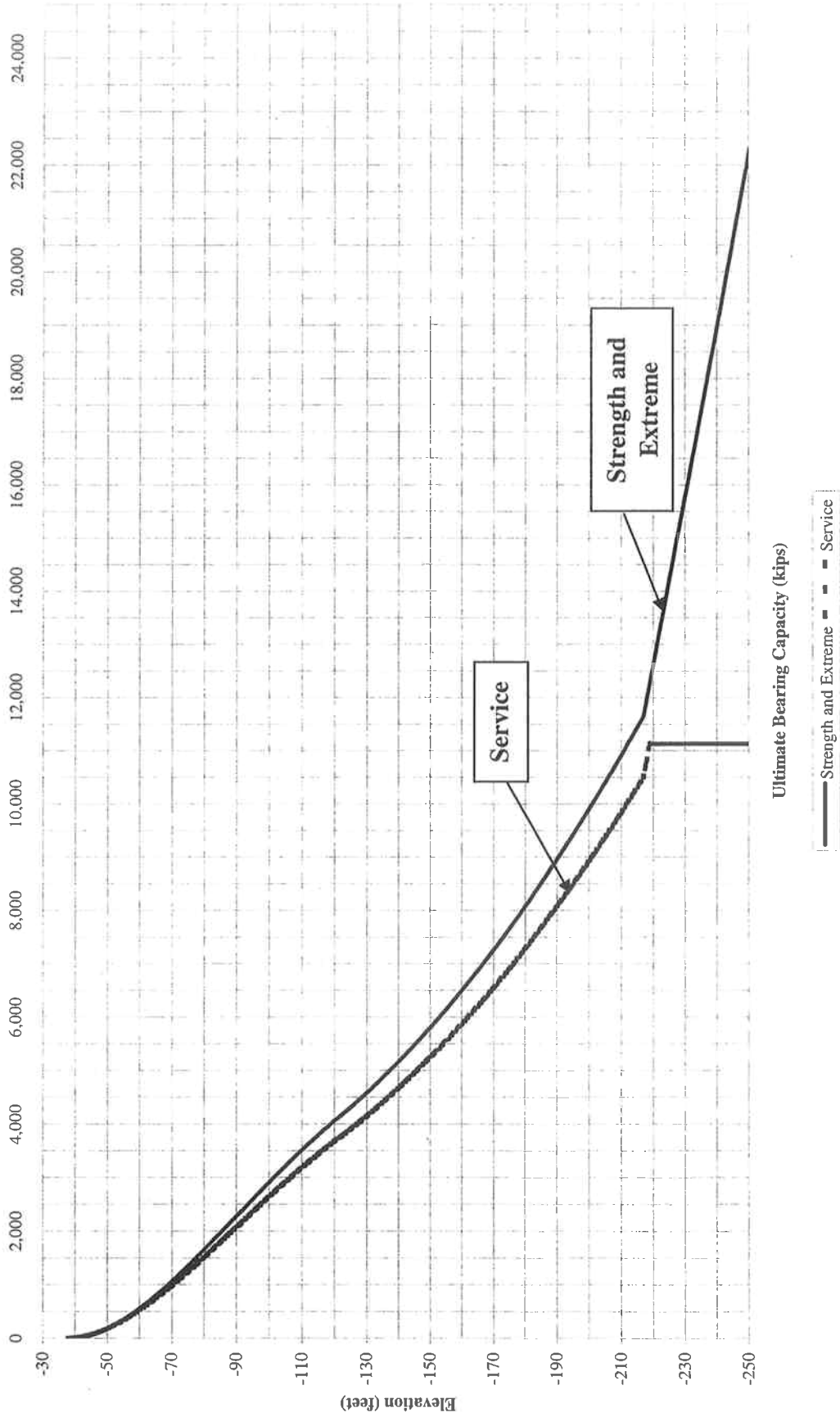

Unfactored End Bearing CRC-RC-003, 12-Foot Diameter Shaft

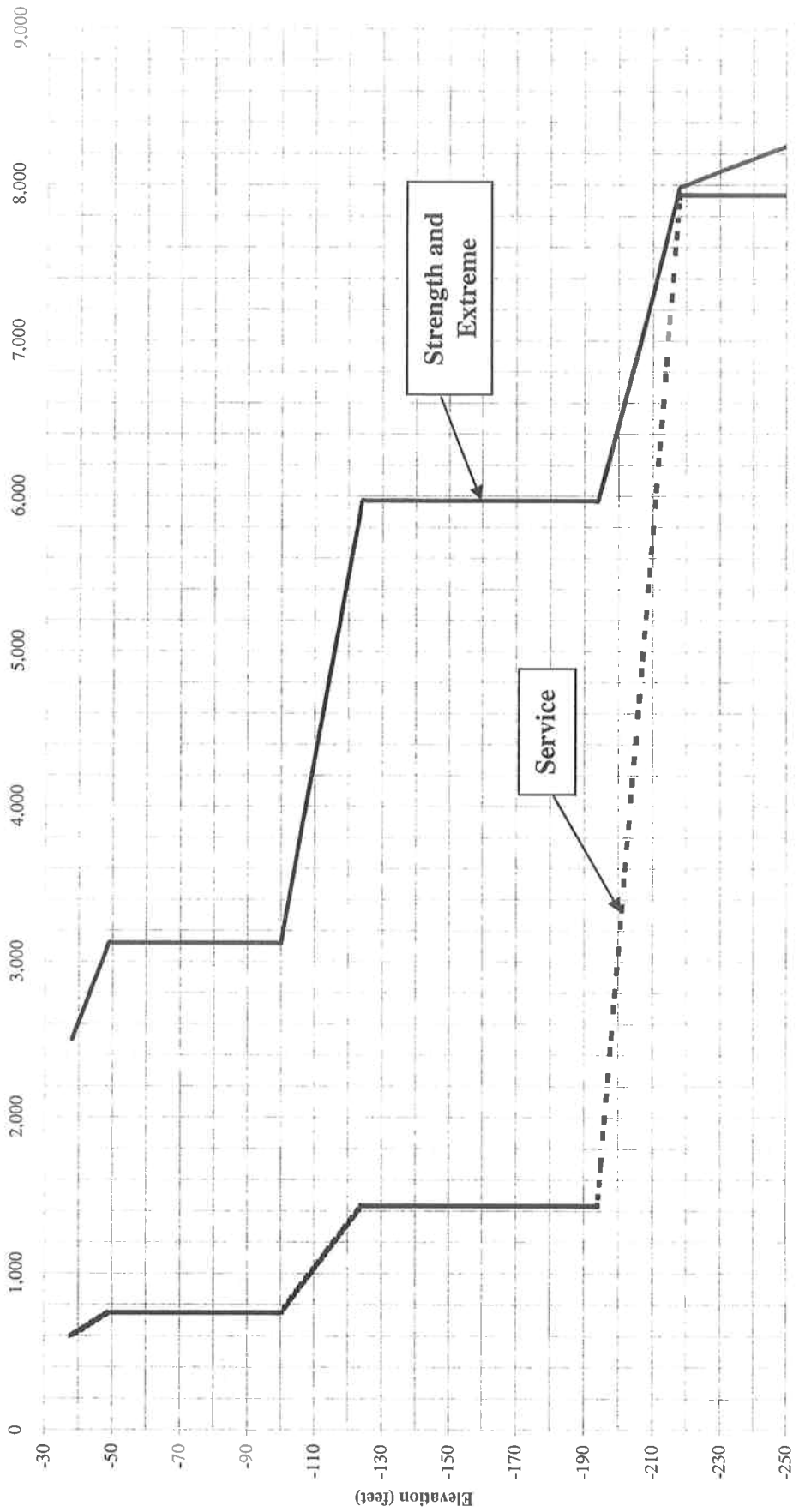

Ultimate Bearing Capacity (kips)

— Strength and Extreme - - - Service

APPENDIX E – DFSAP INPUT PARAMETERS

DFSAP Input Data

Bridge Name/No. SR 5 Columbia River Crossing
Boring No. CRC-RC-001
Ground Surface Elevation -21.2 (ft)
Earthquake Scenario N/A, Static Conditions

Layer	Soil Type	Layer Thickness (ft)	Btm. Elev. (ft)	Effective Unit Weight (pcf)	Friction ⁽¹⁾ Angle (deg)	ϵ_{50} (%)	Liq.	Soil Cohesion (psf)	s_u at Top of Layer (psf)	s_u at Bottom of Layer (psf)	Rock Comp. Stgth (psf)	SPT Corrected Blowcounts (bpf)	Fines Content (%)	Angularity
1	Sand	8	-29	115	30	0.600	No							
2	Sand	37	-66	120	31	0.360	No							
4	Sand	38	-104	125	32	0.125	No							
5	Sand	>50	N/A	130	45	0.020	No							

⁽¹⁾ For Rock, this is the effective friction angle of the rock mass.

Bridge Name/No. SR 5 Columbia River Crossing
Boring No. CRC-RC-002
Ground Surface Elevation -18.5 (ft)
Earthquake Scenario N/A, Static Conditions

Layer	Soil Type	Layer Thickness (ft)	Btm. Elev. (ft)	Effective Unit Weight (pcf)	Friction ⁽¹⁾ Angle (deg)	ϵ_{50} (%)	Liq.	Soil Cohesion (psf)	s_u at Top of Layer (psf)	s_u at Bottom of Layer (psf)	Rock Comp. Stgth (psf)	SPT Corrected Blowcounts (bpf)	Fines Content (%)	Angularity
1	Sand	23	-42	115	31	0.640	No							
2	Sand	100	-142	120	32	0.310	No							
3	Sand	75	-217	125	36	0.120	No							
4	Sand	>50	N/A	130	45	0.020	No							

⁽¹⁾ For Rock, this is the effective friction angle of the rock mass.

Bridge Name/No. SR 5 Columbia River Crossing
Boring No(s). CRC-RC-003
Ground Surface Elevation -36.8 (ft)
Earthquake Scenario N/A, Static Conditions

Layer	Soil Type	Layer Thickness (ft)	Btm. Elev. (ft)	Effective Unit Weight (pcf)	Friction ⁽¹⁾ Angle (deg)	ϵ_{50} (%)	Liq.	Soil Cohesion (psf)	s_u at Top of Layer (psf)	s_u at Bottom of Layer (psf)	Rock Comp. Stgth (psf)	SPT Corrected Blowcounts (bpf)	Fines Content (%)	Angularity
1	Sand	11	-48	120	31	0.625	No							
2	Sand	75	-123	125	32	0.430	No							
3	Sand	94	-217	127	35	0.100	No							
4	Sand	>50	N/A	130	45	0.020	No							

⁽¹⁾ For Rock, this is the effective friction angle of the rock mass.

DFSAP Input Data

Bridge Name/No. SR 5 Columbia River Crossing
Boring No. CRC-RC-001
Ground Surface Elevation -21.2 (ft)
Earthquake Scenario 100 Yr Event

Layer	Soil Type	Layer Thickness (ft)	Btm. Elev. (ft)	Effective Unit Weight (pcf)	Friction ⁽¹⁾ Angle (deg)	ϵ_{50} (%)	Liq.	Soil Cohesion (psf)	s_u at Top of Layer (psf)	s_u at Bottom of Layer (psf)	Rock Comp. Stgth (psf)	SPT Corrected Blowcounts (bpf)	Fines Content (%)	Angularity
1	Sand	8	-29	115	30	0.600	Yes					4	4	Sub-Rounded
2	Sand	37	-66	120	31	0.360	Yes					9	4	Sub-Rounded
3	Sand	1	-67	125	32	0.125	Yes					26	4	
4	Sand	37	-104	125	32	0.125	No							
5	Sand	>50	N/A	130	45	0.020	No							

⁽¹⁾ For Rock, this is the effective friction angle of the rock mass.

Bridge Name/No. SR 5 Columbia River Crossing
Boring No. CRC-RC-002
Ground Surface Elevation -18.5 (ft)
Earthquake Scenario 100 Yr Event

Layer	Soil Type	Layer Thickness (ft)	Btm. Elev. (ft)	Effective Unit Weight (pcf)	Friction ⁽¹⁾ Angle (deg)	ϵ_{50} (%)	Liq.	Soil Cohesion (psf)	s_u at Top of Layer (psf)	s_u at Bottom of Layer (psf)	Rock Comp. Stgth (psf)	SPT Corrected Blowcounts (bpf)	Fines Content (%)	Angularity
1	Sand	13	-32	115	31	0.640	Yes					8	4	Sub-Rounded
2	Sand	10	-42	115	31	0.640	No							
3	Sand	100	-142	120	32	0.310	No							
4	Sand	75	-217	125	36	0.120	No							
5	Sand	>50	N/A	130	45	0.020	No							

⁽¹⁾ For Rock, this is the effective friction angle of the rock mass.

Bridge Name/No. SR 5 Columbia River Crossing
Boring No(s). CRC-RC-003
Ground Surface Elevation -36.8 (ft)
Earthquake Scenario 100 Yr Event

Layer	Soil Type	Layer Thickness (ft)	Btm. Elev. (ft)	Effective Unit Weight (pcf)	Friction ⁽¹⁾ Angle (deg)	ϵ_{50} (%)	Liq.	Soil Cohesion (psf)	s_u at Top of Layer (psf)	s_u at Bottom of Layer (psf)	Rock Comp. Stgth (psf)	SPT Corrected Blowcounts (bpf)	Fines Content (%)	Angularity
1	Sand	11	-48	120	31	0.625	No							
2	Sand	75	-123	125	32	0.430	No							
3	Sand	94	-217	127	35	0.100	No							
4	Sand	>50	N/A	130	45	0.020	No							

⁽¹⁾ For Rock, this is the effective friction angle of the rock mass.

DFSAP Input Data

Bridge Name/No. SR 5 Columbia River Crossing
Boring No. CRC-RC-001
Ground Surface Elevation -21.2 (ft)
Earthquake Scenario 500 Yr Event

Layer	Soil Type	Layer Thickness (ft)	Btm. Elev. (ft)	Effective Unit Weight (pcf)	Friction Angle (deg) ⁽¹⁾	ε ₅₀ (%)	Liq.	Soil Cohesion (psf)	s _u at Top of Layer (psf)	s _u at Bottom of Layer (psf)	Rock Comp. Stgth (psf)	SPT Corrected Blowcounts (bpf)	Fines Content (%)	Angularity
1	Sand	8	-29	115	30	0.600	Yes					4	4	Sub-Rounded
2	Sand	37	-66	120	31	0.360	Yes					9	3	Sub-Rounded
3	Sand	28	-94	125	32	0.125	Yes					15	4	Sub-Rounded
4	Sand	10	-104	125	32	0.125	No							
5	Sand	>50 ft	N/A	130	45	0.020	No							

⁽¹⁾ For Rock, this is the effective friction angle of the rock mass.

Bridge Name/No. SR 5 Columbia River Crossing
Boring No. CRC-RC-002
Ground Surface Elevation -18.5 (ft)
Earthquake Scenario 500 Yr Event

Layer	Soil Type	Layer Thickness (ft)	Btm. Elev. (ft)	Effective Unit Weight (pcf)	Friction Angle (deg) ⁽¹⁾	ε ₅₀ (%)	Liq.	Soil Cohesion (psf)	s _u at Top of Layer (psf)	s _u at Bottom of Layer (psf)	Rock Comp. Stgth (psf)	SPT Corrected Blowcounts (bpf)	Fines Content (%)	Angularity
1	Sand	23	-42	120	31	0.640	Yes					8	2	Sub-Rounded
2	Sand	3	-45	125	32	0.310	Yes							
3	Sand	97	-142	125	32	0.310	No							
4	Sand	75	-217	127	36	0.120	No							
5	Sand	>50	N/A	130	45	0.020	No							

⁽¹⁾ For Rock, this is the effective friction angle of the rock mass.

Bridge No. or Name SR 5 Columbia River Crossing
Boring No(s). CRC-RC-003
Ground Surface Elevation -96.8 (ft)
Earthquake Scenario 500 Yr Event

Layer	Soil Type	Layer Thickness (ft)	Btm. Elev. (ft)	Effective Unit Weight (pcf)	Friction Angle (deg) ⁽¹⁾	ε ₅₀ (%)	Liq.	Soil Cohesion (psf)	s _u at Top of Layer (psf)	s _u at Bottom of Layer (psf)	Rock Comp. Stgth (psf)	SPT Corrected Blowcounts (bpf)	Fines Content (%)	Angularity
1	Sand	11	-48	120	31	0.625	Yes					13	4	Sub-Rounded
2	Sand	17	-65	125	32	0.430	Yes					23	4	Sub-Rounded
3	Sand	58	-123	125	32	0.430	No							
4	Sand	94	-217	127	35	0.100	No							
5	Sand	>50	N/A	130	45	0.020	No							

⁽¹⁾ For Rock, this is the effective friction angle of the rock mass.

DFSAP Input Data

Bridge Name/No. SR 5 Columbia River Crossing
 Boring No. CRC-RC-001
 Ground Surface Elevation -21.2 (ft)
 Earthquake Scenario 1000 Yr Event

Layer	Soil Type	Layer Thickness (ft)	Btm. Elev. (ft)	Effective Unit Weight (pcf)	Friction ⁽¹⁾ Angle (deg)	ϵ_{50} (%)	Liq.	Soil Cohesion (psf)	s_u at Top of Layer (psf)	s_u at Bottom of Layer (psf)	Rock Comp. Stgth (psf)	SPT Corrected Blowcounts (bpf)	Fines Content (%)	Angularity
1	Sand	8	-29	115	30	0.600	Yes					4	4	Sub-Rounded
2	Sand	37	-66	120	31	0.360	Yes					9	3	Sub-Rounded
3	Sand	30	-96	125	32	0.125	Yes					15	4	Sub-Rounded
4	Sand	8	-104	125	32	0.125	No							
5	Sand	>50 ft	N/A	130	45	0.020	No							

⁽¹⁾ For Rock, this is the effective friction angle of the rock mass.

Bridge Name/No. SR 5 Columbia River Crossing
 Boring No. CRC-RC-002
 Ground Surface Elevation -18.5 (ft)
 Earthquake Scenario 1000 Yr Event

Layer	Soil Type	Layer Thickness (ft)	Btm. Elev. (ft)	Effective Unit Weight (pcf)	Friction ⁽¹⁾ Angle (deg)	ϵ_{50} (%)	Liq.	Soil Cohesion (psf)	s_u at Top of Layer (psf)	s_u at Bottom of Layer (psf)	Rock Comp. Stgth (psf)	SPT Corrected Blowcounts (bpf)	Fines Content (%)	Angularity
1	Sand	23	-42	120	31	0.640	Yes					8	2	Sub-Rounded
2	Sand	23	-65	125	32	0.310	Yes					15	3	Sub-Rounded
3	Sand	77	-142	125	32	0.310	No							
4	Sand	75	-217	127	36	0.120	No							
5	Sand	>50	N/A	130	45	0.020	No							

⁽¹⁾ For Rock, this is the effective friction angle of the rock mass.

Bridge Name/No. SR 5 Columbia River Crossing
 Boring No. CRC-RC-003
 Ground Surface Elevation -36.8 (ft)
 Earthquake Scenario 1000 Yr Event

Layer	Soil Type	Layer Thickness (ft)	Btm. Elev. (ft)	Effective Unit Weight (pcf)	Friction ⁽¹⁾ Angle (deg)	ϵ_{50} (%)	Liq.	Soil Cohesion (psf)	s_u at Top of Layer (psf)	s_u at Bottom of Layer (psf)	Rock Comp. Stgth (psf)	SPT Corrected Blowcounts (bpf)	Fines Content (%)	Angularity
1	Sand	11	-48	120	31	0.625	Yes					13	4	Sub-Rounded
2	Sand	26	-74	125	32	0.430	Yes					19	5	Sub-Rounded
3	Sand	49	-123	125	32	0.430	No							
4	Sand	94	-217	127	35	0.100	No							
5	Sand	>50	N/A	130	45	0.020	No							

⁽¹⁾ For Rock, this is the effective friction angle of the rock mass.

DFSAP Input Data

Bridge Name/No. SR 5 Columbia River Crossing
 Boring No. CRC-RC-001
 Ground Surface Elevation -21.2 (ft)
 Earthquake Scenario 2500 Yr Event

Layer	Soil Type	Layer Thickness (ft)	Btm. Elev. (ft)	Effective Unit Weight (pcf)	Friction ⁽¹⁾ Angle (deg)	ϵ_{50} (%)	Liq.	Soil Cohesion (psf)	s_u at Top of Layer (psf)	s_u at Bottom of Layer (psf)	Rock Comp. Stgth (psf)	SPT Corrected Blowcounts (bpf)	Fines Content (%)	Angularity
1	Sand	8	-29	115	30	0.600	Yes					4	4	Sub-Rounded
2	Sand	37	-66	120	31	0.360	Yes					9	3	Sub-Rounded
3	Sand	30	-96	125	32	0.125	Yes					15	4	Sub-Rounded
4	Sand	8	-104	125	32	0.125	No							
5	Sand	>50 ft	N/A	130	45	0.020	No							

⁽¹⁾ For Rock, this is the effective friction angle of the rock mass.

Bridge Name/No. SR 5 Columbia River Crossing
 Boring No. CRC-RC-002
 Ground Surface Elevation -18.5 (ft)
 Earthquake Scenario 2500 Yr Event

Layer	Soil Type	Layer Thickness (ft)	Btm. Elev. (ft)	Effective Unit Weight (pcf)	Friction ⁽¹⁾ Angle (deg)	ϵ_{50} (%)	Liq.	Soil Cohesion (psf)	s_u at Top of Layer (psf)	s_u at Bottom of Layer (psf)	Rock Comp. Stgth (psf)	SPT Corrected Blowcounts (bpf)	Fines Content (%)	Angularity
1	Sand	23	-42	120	31	0.640	Yes					8	2	Sub-Rounded
2	Sand	52	-94	125	32	0.310	Yes					15	3	Sub-Rounded
3	Sand	48	-142	125	32	0.310	No							
4	Sand	75	-217	127	36	0.120	No							
5	Sand	>50 ft	N/A	130	45	0.020	No							

⁽¹⁾ For Rock, this is the effective friction angle of the rock mass.

Bridge No. or Name SR 5 Columbia River Crossing
 Boring No. CRC-RC-003
 Ground Surface Elevation -36.8 (ft)
 Earthquake Scenario 2500 Yr Event

Layer	Soil Type	Layer Thickness (ft)	Btm. Elev. (ft)	Effective Unit Weight (pcf)	Friction ⁽¹⁾ Angle (deg)	ϵ_{50} (%)	Liq.	Soil Cohesion (psf)	s_u at Top of Layer (psf)	s_u at Bottom of Layer (psf)	Rock Comp. Stgth (psf)	SPT Corrected Blowcounts (bpf)	Fines Content (%)	Angularity
1	Sand	11	-48	120	31	0.625	Yes					13	4	Sub-Rounded
2	Sand	50	-98	125	32	0.430	Yes					19	5	Sub-Rounded
3	Sand	25	-123	125	32	0.430	No							
4	Sand	94	-217	127	35	0.100	No							
5	Sand	>50 ft	N/A	130	45	0.020	No							

⁽¹⁾ For Rock, this is the effective friction angle of the rock mass.

This page left blank intentionally.