

Last revised on : 02/22/2018

SR JOB NO. 10.1-A1-1 SHEET

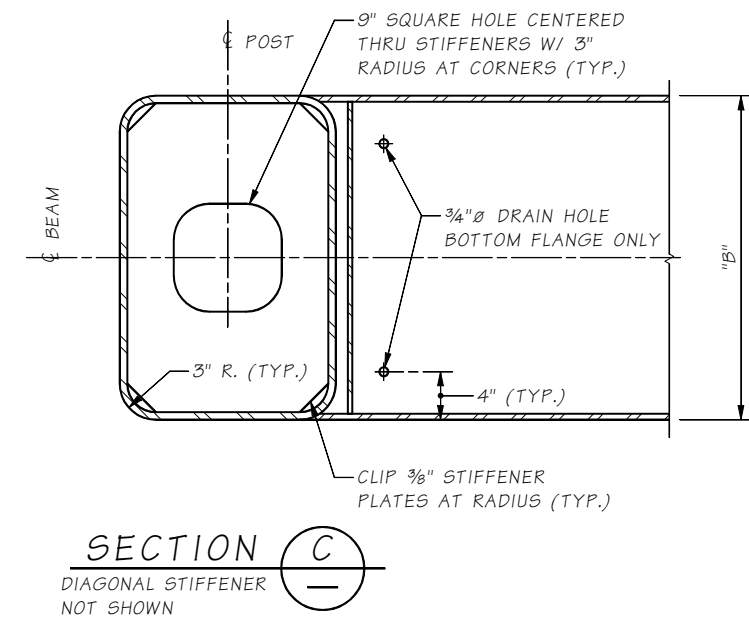
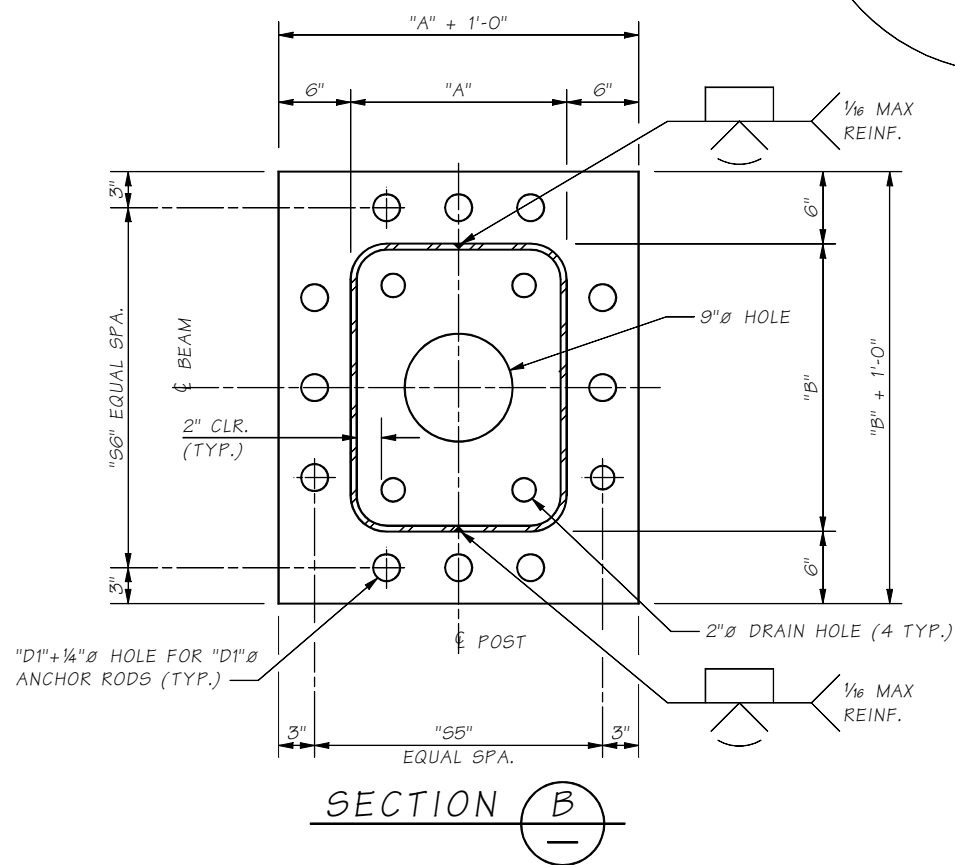
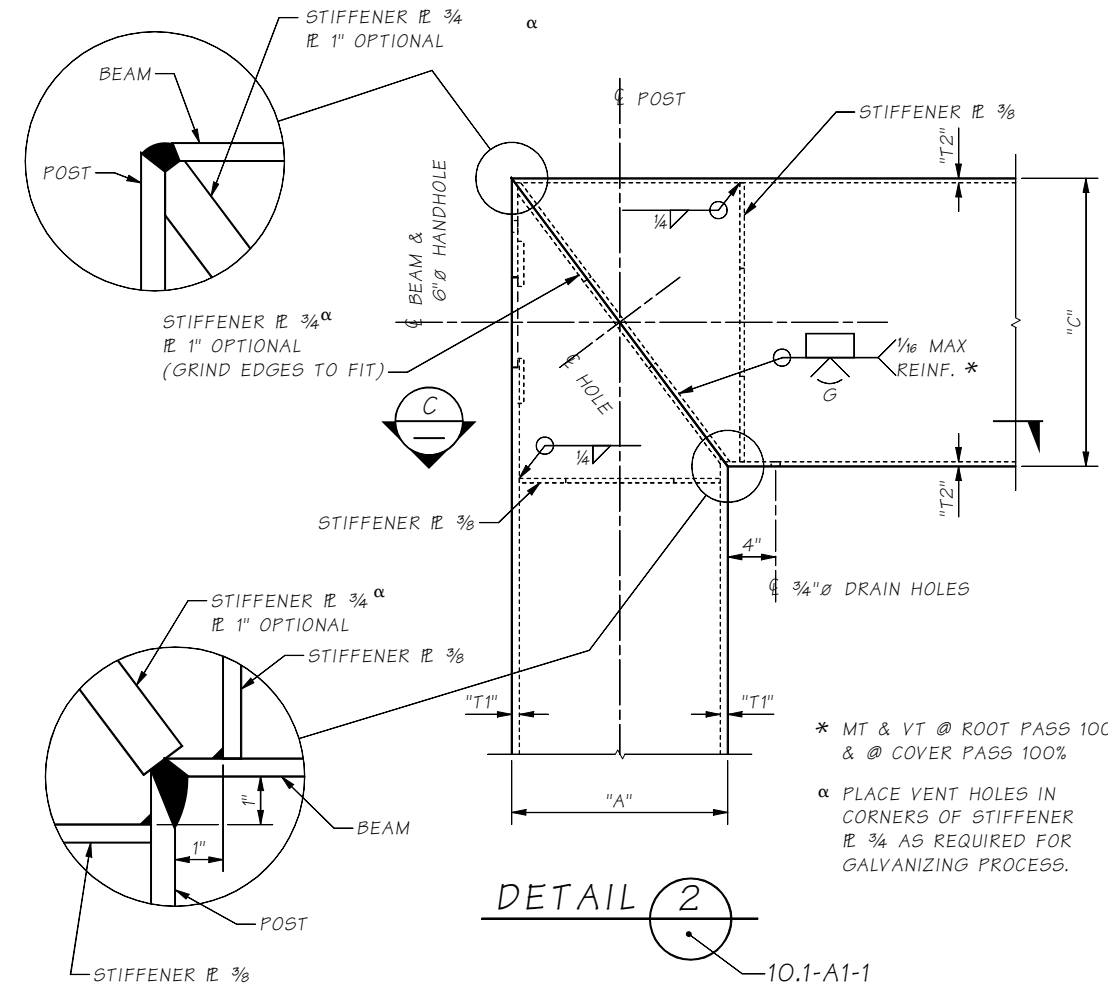
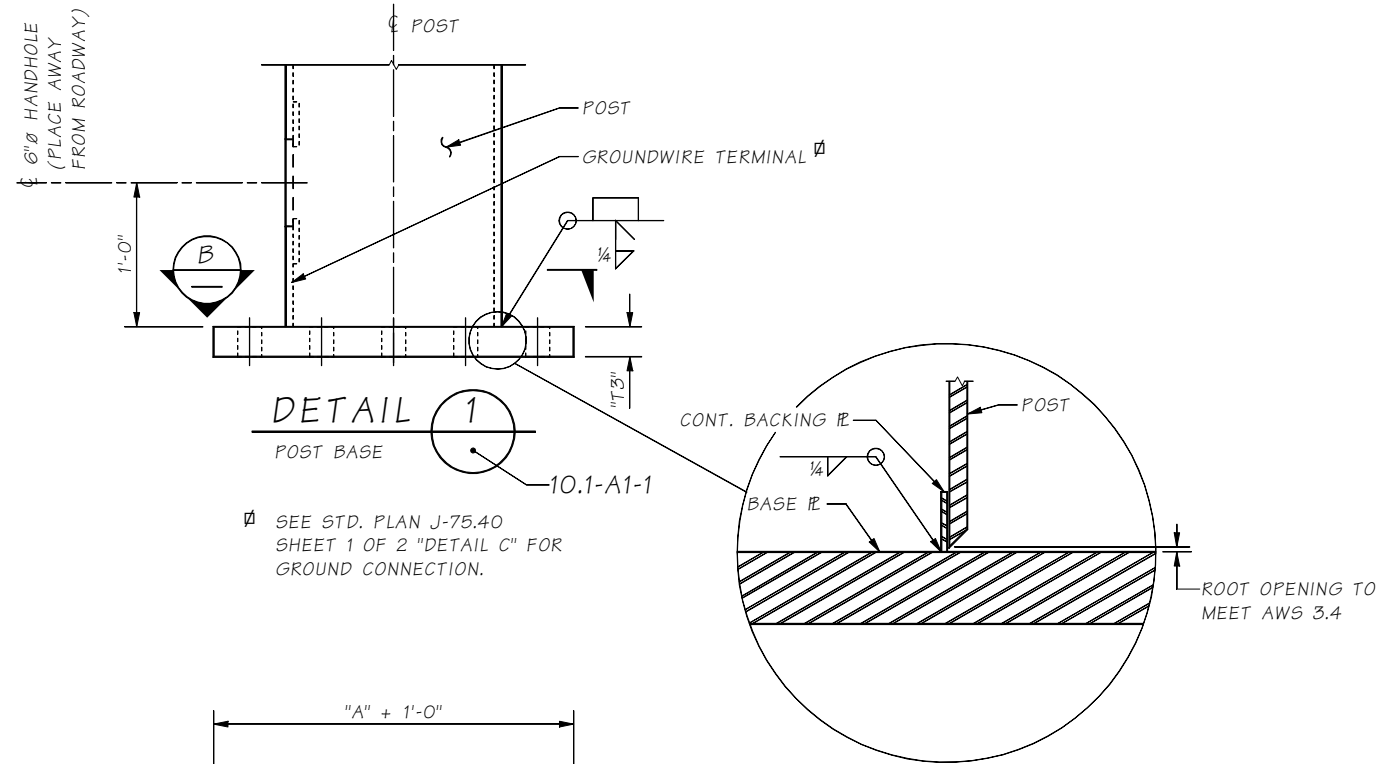

Bridge Design Engr.	M:\STANDARDS\Sign Bridges\MT_SIGN_BRIDGE_STRUCT_DETAILS_1.MAN						
Supervisor			REGION NO.	STATE	FED. AID PROJ. NO.	SHEET NO.	TOTAL SHEETS
Designed By			10	WASH.			
Checked By			JOB NUMBER				
Detailed By							
Bridge Projects Engr.							
Prelim. Plan By							
Architect/Specialist	DATE	REVISION	BY	APPD			

BRIDGE AND STRUCTURES OFFICE



STANDARD MONOTUBE SIGN STRUCTURES

MONOTUBE SIGN BRIDGE STRUCTURAL DETAILS 1

BRIDGE SHEET NO.
SHEET
OF
SHEETS