

Chapter 730

730.01	General
730.02	References
730.03	Design Principles
730.04	Design Requirements
730.05	Guidelines for Wall/Slope Selection
730.06	Design Responsibility and Process
730.07	Documentation

730.01 General

The function of a retaining wall is to form a nearly vertical face through confinement and/or strengthening of a mass of earth or other bulk material. Likewise, the function of a reinforced slope is to strengthen the mass of earth or other bulk material such that a steep (up to 1H:2V) slope can be formed. In both cases, the purpose of constructing such structures is to make maximum use of limited right of way. The difference between the two is that a wall uses a structural facing, whereas a steep reinforced slope does not require a structural facing. Reinforced slopes typically use a permanent erosion control matting with low vegetation as a slope cover to prevent erosion. (See the *Roadside Manual* for more information.)

To lay out and design a retaining wall or reinforced slope, consider the following items:

- Functional classification
- Highway geometry
- Design Clear Zone requirements (see [Chapter 1600](#))
- Amount of excavation required
- Traffic characteristics
- Constructibility
- Impact to adjacent environmentally sensitive areas
- Impact to adjacent structures
- Potential added lanes
- Length and height of wall
- Material to be retained
- Foundation support and potential for differential settlement
- Groundwater
- Earthquake loads
- Right of way costs
- Need for construction easements
- Risk
- Overall cost
- Visual appearance

If the wall or toe of a reinforced slope is to be located adjacent to the right of way line, consider the space needed in front of the wall/slope to construct it.

(1) Retaining Wall Classifications

Retaining walls are generally classified as gravity, semigravity, nongravity cantilever, or anchored. The various wall types and their classifications are summarized in Exhibits 730-1 through 730-6.

(a) Gravity Walls

Gravity walls derive their capacity to resist lateral soil loads through a combination of dead weight and sliding resistance. Gravity walls can be further subdivided into rigid gravity walls, prefabricated modular gravity walls, and mechanically stabilized earth (MSE) gravity walls.

Rigid gravity walls consist of a solid mass of concrete or mortared rubble, and they use the weight of the wall itself to resist lateral loads.

Prefabricated modular gravity walls consist of interlocking soil or rock-filled concrete, steel, or wire modules or bins (such as gabions). The combined weight resists the lateral loads from the soil.

MSE gravity walls use strips, bars, or mats of steel or polymeric reinforcement to reinforce the soil and create a reinforced soil block behind the face. The reinforced soil block then acts as a unit and resists the lateral soil loads through the dead weight of the reinforced mass. MSE walls may be constructed as fill walls, with fill and reinforcement placed in alternate layers to create a reinforced mass, or reinforcement may be drilled into an existing soil/rock mass using grouted anchor technology to create a reinforced soil mass (soil nail walls).

(b) Semigravity Walls

Semigravity walls rely more on structural resistance through cantilevering action of the wall stem. Generally, the backfill for a semigravity wall rests on part of the wall footing. The backfill, in combination with the weight of the wall and footing, provides the dead weight for resistance. An example of a semigravity wall is the reinforced concrete wall provided in the *Standard Plans*.

(c) Nongravity Cantilever Walls

Nongravity cantilever walls rely strictly on the structural resistance of the wall in which vertical elements of the wall are partially embedded in the soil or rock to provide fixity. These vertical elements may consist of piles (such as soldier piles or sheet piles), caissons, or drilled shafts. The vertical elements may form the entire wall face or they may be spanned structurally using timber lagging or other materials to form the wall face.

(d) Anchored Walls

Anchored walls derive their lateral capacity through anchors embedded in stable soil or rock below or behind all potential soil/rock failure surfaces. Anchored walls are similar to nongravity cantilevered walls except that anchors embedded in the soil/rock are attached to the wall facing structure to provide lateral resistance. Anchors typically consist of deadman or grouted soil/rock anchors.

Reinforced slopes are similar to MSE walls in that they also use fill and reinforcement placed in alternate layers to create a reinforced soil mass. However, the face is typically built at a 1.2H:1V to 1H:2V slope.

Rockerries (rock walls) behave to some extent like gravity walls. However, the primary function of a rockery is to prevent erosion of an oversteepened but technically stable slope. Rockeries consist of large, well-fitted rocks stacked on top of one another to form a wall.

An example of a rockery and reinforced slope is provided in [Exhibit 730-10](#).

730.02 References

(1) Federal/State Laws and Codes

[Washington Administrative Code \(WAC\) 296-155](#), Safety standards for construction work

(2) Design Guidance

[Bridge Design Manual](#), M 23-50, WSDOT

[Standard Plans for Road, Bridge, and Municipal Construction \(Standard Plans\)](#), M 21-01, WSDOT

[Plans Preparation Manual](#), M 22-31, WSDOT

[Roadside Manual](#), M 25-30, WSDOT

730.03 Design Principles

The design of a retaining wall or reinforced slope consists of the following principal activities:

- Develop wall/slope geometry
- Provide adequate subsurface investigation
- Evaluate loads and pressures that will act on the structure
- Design the structure to withstand the loads and pressures
- Design the structure to meet aesthetic requirements
- Ensure wall/slope constructibility
- Coordinate with other design elements

The structure and adjacent soil mass also needs to be stable as a system, and the anticipated wall settlement needs to be within acceptable limits.

730.04 Design Requirements

(1) Wall/Slope Geometry

Wall/slope geometry is developed considering the following:

- Geometry of the transportation facility itself
- Design Clear Zone requirements (see [Chapter 1600](#))
- Flare rate and approach slope when inside the Design Clear Zone (see [Chapter 1610](#))
- Right of way constraints
- Existing ground contours
- Existing and future utility locations
- Impact to adjacent structures
- Impact to environmentally sensitive areas

For wall/slope geometry, also consider the foundation embedment and type anticipated, which requires coordination between the various design groups involved.

Retaining walls are designed to limit the potential for snagging vehicles by removing protruding objects (such as bridge columns, light fixtures, or sign supports).

Provide a traffic barrier shape at the base of a new retaining wall constructed 12 feet or less from the edge of the nearest traffic lane. The traffic barrier shape is optional at the base of the new portion when an existing vertical-faced wall is being extended (or the existing wall may be retrofitted for continuity). Depending on the application, precast or cast-in-place Single Slope Concrete Barrier with vertical back or Type 4 Concrete Barrier may be used for both new and existing walls except when the barrier face can be cast as an integral part of a new wall. Design analyses may be considered, but they require approval as prescribed in [Chapter 300](#). A design analysis is not required where sidewalk exists in front of the wall or in other situations where the wall face is otherwise inaccessible to traffic.

(2) Investigation of Soils

All retaining wall and reinforced slope structures require an investigation of the underlying soil/rock that supports the structure. [Chapter 610](#) provides guidance on how to complete this investigation. A soil investigation is an integral part of the design of any retaining wall or reinforced slope. The stability of the underlying soils, their potential to settle under the imposed loads, the usability of any existing excavated soils for wall/reinforced slope backfill, and the location of the groundwater table are determined through the geotechnical investigation.

(3) Geotechnical and Structural Design

The structural elements of the wall or slope and the soil below, behind, and/or within the structure are designed together as a system. The wall/slope system is designed for overall external stability as well as internal stability. Overall external stability includes stability of the slope the wall/reinforced slope is a part of and the local external stability (overturning, sliding, and bearing capacity). Internal stability includes resistance of the structural members to load and, in the case of MSE walls and reinforced slopes, pullout capacity of the structural members or soil reinforcement from the soil.

(a) Scour

At any location where a retaining wall or reinforced slope can be in contact with water (such as a culvert outfall, ditch, wetland, lake, river, or floodplain), there is a risk of scour at the toe. This risk must be analyzed. Contact the HQ Geotechnical Office and HQ Hydraulics Office to determine whether a scour analysis is required.

(4) Drainage Design

One of the principal causes of retaining wall/slope failure is the additional hydrostatic load imposed by an increase in the water content in the material behind the wall or slope. This condition results in a substantial increase in the lateral loads behind the wall/slope since the material undergoes a possible increase in unit weight, water pressure is exerted on the back of the wall, and the soil shear strength undergoes a possible reduction. To alleviate this, adequate drainage for the retaining wall/slope

needs to be considered in the design stage and reviewed by the region Materials Engineer during construction. The drainage features shown in the *Standard Plans* are the minimum basic requirements. Underdrains behind the wall/slope need to daylight at some point in order to adequately perform their drainage function. Provide positive drainage at periodic intervals to prevent entrapment of water.

Native soil may be used for retaining wall and reinforced slope backfill if it meets the requirements for the particular wall/slope system. In general, use backfill that is free-draining and granular in nature. Exceptions to this can be made depending on the site conditions as determined by the Geotechnical Office of the Headquarters (HQ) Materials Laboratory.

A typical drainage detail for a gravity wall (in particular, an MSE wall) is shown in [Exhibit 730-11](#). Include drainage details with a wall unless otherwise recommended to be deleted by the Region Materials Engineer or HQ Geotechnical Office.

(5) Aesthetics

Retaining walls and slopes can have a pleasing appearance that is compatible with the surrounding terrain and other structures in the vicinity. To the extent possible within functional requirements and cost-effectiveness criteria, this aesthetic goal is to be met for all visible retaining walls and reinforced slopes.

Aesthetic requirements include consideration of the wall face material, top profile, terminals, and surface finish (texture, color, and pattern). Where appropriate, provide planting areas and irrigation conduits. These will visually soften walls and blend them with adjacent areas. Avoid short sections of retaining wall or steep slope where possible.

In higher walls, variations in slope treatment are recommended for a pleasing appearance. High continuous walls are generally not desirable from an aesthetic standpoint, because they can be quite imposing. Consider stepping high or long retaining walls in areas of high visibility. Plantings may be considered between wall steps.

Approval by the State Bridge and Structures Architect is required on all retaining wall aesthetics, including finishes, materials, and configuration (see [Chapter 950](#)).

(6) Constructability

Consider the potential effect that site constraints might have on the constructability of the specific wall/slope. Constraints to be considered include but are not limited to site geometry, access, time required to construct the wall, environmental issues, and impact on traffic flow and other construction activities.

(7) Coordination With Other Design Elements

(a) Other Design Elements

Retaining wall and slope designs are to be coordinated with other elements of the project that might interfere with or impact the design or construction of the wall/slope. Also consider drainage features; utilities; luminaire or sign structures; adjacent retaining walls or bridges; concrete traffic barriers; and beam guardrails. Locate these design elements in a manner that will minimize the impacts to the wall elements. In general, locate obstructions within the wall backfill (such as

guardrail posts, drainage features, and minor structure foundations) a minimum of 3 feet from the back of the wall facing units.

Greater offset distances may be required depending on the size and nature of the interfering design element. If possible, locate these elements to miss reinforcement layers or other portions of the wall system. Conceptual details for accommodating concrete traffic barriers and beam guardrails are provided in [Exhibit 730-12](#).

Where impact to the wall elements is unavoidable, the wall system needs to be designed to accommodate these impacts. For example, it may be necessary to place drainage structures or guardrail posts in the reinforced backfill zone of MSE walls. This may require that holes be cut in the upper soil reinforcement layers or that discrete reinforcement strips be splayed around the obstruction. This causes additional load to be carried in the adjacent reinforcement layers due to the missing soil reinforcement or the distortion in the reinforcement layers.

The need for these other design elements and their impacts on the proposed wall systems are to be clearly indicated in the submitted wall site data so the walls can be properly designed. Contact the HQ Bridge and Structures Office (or the Geotechnical Office for geosynthetic walls/slopes and soil nail walls) for assistance regarding this issue.

(b) **Worker Fall Protection**

Department of Labor and Industries regulations require that, when employees are exposed to the possibility of falling from a location 4 feet or more above the roadway (or other lower area), the employer is to ensure fall restraint or fall arrest systems are provided, installed, and implemented.

Design fall protection in accordance with [WAC 296-155-24609](#) for walls that create a potential for a fall of 4 feet or more. During construction or other temporary or emergency condition, fall protection will follow [WAC 296-155](#). Any need for maintenance of the wall's surface or the area at the top can expose employees to a possible fall. If the area at the top will be open to the public, see [Chapter 1510, Pedestrian Facilities](#).

For maintenance of a tall wall's surface (10 feet or more), consider harness tie-offs if other protective means are not provided.

For maintenance of the area at the top of a tall wall, a fall restraint system is required when all of the following conditions will exist:

- A possible fall will be of 4 feet or more.
- Periodic maintenance will be performed on the area at the top.
- The area at the top is not open to the public.

Recommended fall restraint systems are:

- Wire rope railing with top and intermediate rails of ½-inch-diameter steel wire rope.
- Steel pipe railing with 1½-inch nominal outside diameter pipe as posts and top and intermediate rails.
- Concrete as an extension of the height of the retaining wall.

A fall restraint system is to be 42 inches high, plus or minus 3 inches, measured from the top of the finished grade, and capable of withstanding a 200 lb force from any direction, at the top, with minimal deflection. An intermediate cable or rail shall be halfway between the top rail and the platform. A toe board with a minimum height of 4 inches will be provided. Post spacing is no more than 8 feet on centers. (See the *Construction Manual* and [WAC 296-155](#) for fall arrest and protection information.) For wire rope railing, the top railing shall be flagged at not more than 6-foot intervals with high-visibility material.

The designer is to contact maintenance personnel regarding fall protection and debris removal considerations.

Contact the HQ Bridge and Structures Office for design details for any retrofit to an existing retaining wall and for any attachments to a new retaining wall.

730.05 Guidelines for Wall/Slope Selection

Wall/slope selection is dependent on:

- Whether the wall/slope will be located primarily in a cut or fill (how much excavation/shoring will be required to construct the wall or slope).
- If located in a cut, the type of soil/rock present.
- The need for space between the right of way line and the wall/slope or easement.
- The amount of settlement expected.
- The potential for deep failure surfaces to be present.
- The structural capacity of the wall/slope in terms of maximum allowable height.
- The nature of the wall/slope application.
- Whether or not structures or utilities will be located on or above the wall.
- Architectural requirements.
- Overall economy.

(1) *Cut and Fill Considerations*

Due to the construction technique and base width required, some wall types are best suited for cut situations, whereas others are best suited for fill situations. For example, anchored walls and soil nail walls have soil reinforcements drilled into the in-situ soil/rock and are therefore generally used in cut situations. Nongravity cantilevered walls are drilled or cut into the in-situ soil/rock, have narrow base widths, and are also well suited to cut situations. Both types of walls are constructed from the top down. Such walls are also used as temporary shoring to allow other types of walls or other structures to be constructed where considerable excavation will otherwise be required.

MSE walls and reinforced slopes, however, are constructed by placing soil reinforcement between layers of fill from the bottom up and are therefore best suited to fill situations. Furthermore, the base width of MSE walls is typically on the order of 70% of the wall height, which requires considerable excavation in a cut situation. Therefore, in a cut situation, base width requirements usually make MSE structures uneconomical and possibly unconstructible.

Semigravity (cantilever) walls, rigid gravity walls, and prefabricated modular gravity walls are free-standing structural systems built from the bottom up, but they do not rely on soil reinforcement techniques (placement of fill layers with soil reinforcement) to provide stability.

These types of walls generally have a narrower base width than MSE structures (on the order of 50% of the wall height). Both of these factors make these types of walls feasible in fill situations as well as many cut situations.

Reinforced slopes generally require more room overall to construct than a wall because of the sloping face, but they typically are a feasible alternative to a combination wall and fill slope to add a new lane. Reinforced slopes can also be adapted to the existing ground contours to minimize excavation requirements where fill is placed on an existing slope. Reinforced slopes might also be a feasible choice to repair slopes damaged by landslide activity or deep erosion.

Rockeries are best suited to cut situations as they require only a narrow base width, on the order of 30% of the rockery height. Rockeries can be used in fill situations, but the fill heights they support need to be kept relatively low. It is difficult to get the cohesive strength needed in granular fill soils to provide minimal stability of the soil behind the rockery at the steep slope typically used for rockeries in a cut (such as 1H:6V or 1H:4V).

The key considerations in deciding which walls or slopes are feasible are the amount of excavation or shoring required and the overall height. The site geometric constraints are defined to determine these elements. Another consideration is whether or not an easement will be required. For example, a temporary easement might be required for a wall in a fill situation to allow the contractor to work in front of the wall. For walls in cut situations, especially anchored walls and soil nail walls, a permanent easement may be required for the anchors or nails.

(2) Settlement and Deep Foundation Support Considerations

Settlement issues, especially differential settlement, are of primary concern in the selection of walls. Some wall types are inherently flexible and can tolerate a great deal of settlement without suffering structurally. Other wall types are inherently rigid and cannot tolerate much settlement. In general, MSE walls have the greatest flexibility and tolerance to settlement, followed by prefabricated modular gravity walls. Reinforced slopes are also inherently very flexible. For MSE walls, the facing type used can affect the ability of the wall to tolerate settlement. Welded wire and geosynthetic wall facings are the most flexible and the most tolerant to settlement, whereas concrete facings are less tolerant to settlement. In some cases, after the wall settlement is complete, concrete facing can be placed such that the concrete facing does not limit the wall's tolerance to settlement. Facing may also be added for aesthetic reasons.

Semigravity (cantilever) walls and rigid gravity walls have the least tolerance to settlement. In general, total settlement for these types of walls needs to be limited to approximately 1 inch or less. Rockeries also cannot tolerate much settlement, as rocks can shift and fall out. Therefore, semigravity cantilever walls, rigid gravity walls, and rockeries are not used in settlement prone areas.

If very weak soils are present that will not support the wall and are too deep to be overexcavated, or if a deep failure surface is present that results in inadequate slope stability, select a wall type capable of using deep foundation support and/or anchors. In general, MSE walls, prefabricated modular gravity walls, and some rigid gravity walls are not appropriate for these situations. Walls that can be pile-supported, such as concrete semigravity cantilever walls, nongravity cantilever walls, and anchored walls, are more appropriate for these situations.

(3) Feasible Wall Heights and Limitations

Feasible wall heights are affected by issues such as the capacity of the wall structural elements, past experience with a particular wall, current practice, seismic risk, long-term durability, and aesthetics.

For height limitations, see Exhibits [730-1](#) through [730-6](#).

(4) Supporting Structures or Utilities

Not all walls are acceptable to support other structures or utilities. Issues that are to be considered include the potential for the wall to deform due to the structure foundation load, interference between the structure foundation and the wall components, and the potential long-term durability of the wall system. Using retaining walls to support other structures is considered to be a critical application, requiring a special design. In general, soil nail walls, semigravity cantilever walls, nongravity cantilever walls, and anchored walls are appropriate for use in supporting bridge and building structure foundations. In addition to these walls, MSE and prefabricated modular gravity walls may be used to support other retaining walls, noise walls, and minor structure foundations such as those for sign bridges and signals. On a project-specific basis, MSE walls can be used to support bridge and building foundations as approved by the HQ Bridge and Structures Office.

Consider the location of any utilities behind the wall or reinforced slope when making wall/slope selections. This is mainly an issue for walls that use some type of soil reinforcement and for reinforced slopes. It is best not to place utilities within a reinforced soil backfill zone because it will be impossible to access the utility from the ground surface without cutting through the soil reinforcement layers, thereby compromising the integrity of the wall.

Sometimes utilities, culverts, pipe arches, and so on must penetrate the face of a wall. Not all walls and facings are compatible with such penetrations. Consider how the facing can be formed around the penetration so that backfill soil cannot pipe or erode through the face. Contact the HQ Bridge and Structures Office for assistance regarding this issue.

(5) Facing Options

Facing selection depends on the aesthetic and structural needs of the wall system. Wall settlement may also affect the feasibility of the facing options. More than one wall facing may be available for a given system. Consider the available facing options when selecting a particular wall.

(a) MSE Walls

For MSE walls, facing options typically include:

- Precast modular panels.
- In some cases, full height precast concrete panels. Full height panels are generally limited to walls with a maximum height of 20 feet placed in areas where minimal settlement is expected.
- Welded wire facing.
- Timber facing.
- Shotcrete facing with treatment options that vary from a simple broom finish to a textured and colored finish.

- Segmental masonry concrete blocks.
- Cast-in-place concrete facing with various texturing options.

Plantings on welded wire facings can be attempted in certain cases. The difficulty is in providing a soil at the wall face that is suitable for growing plants and meets engineering requirements in terms of soil compressibility, strength, and drainage. If plantings in the wall face are attempted, use only small plants, vines, and grasses. Small bushes may be considered for plantings between wall steps. Larger bushes or trees are not considered in these cases due to the loads they can create on the wall face.

Geosynthetic facings are not acceptable for permanent facings due to potential facing degradation when exposed to sunlight. For permanent applications, use some type of timber, welded wire, or concrete face for geosynthetic walls. Shotcrete, masonry concrete blocks, cast-in-place concrete, welded wire, or timber are typically used for geosynthetic wall facings.

(b) Soil Nail Walls

Soil nail walls can use either architecturally treated shotcrete or a cast-in-place facia wall textured as needed to produce the desired appearance.

(c) Prefabricated Modular Gravity Walls

For prefabricated modular gravity walls, the facing generally consists of the structural bin or crib elements used to construct the walls. For some walls, the elements can be rearranged to form areas for plantings. In some cases, textured structural elements might also be feasible. This is also true of rigid gravity walls, though planting areas on the face of rigid gravity walls are generally not feasible. The concrete facing for semigravity cantilever walls can be textured as needed to produce the desired appearance.

(d) Nongravity Cantilevered Walls

For nongravity cantilevered walls and anchored walls, a textured cast-in-place or precast facia wall is usually installed to produce the desired appearance.

(6) Cost Considerations

Usually, more than one wall type is feasible for a given situation. Consider initial and future maintenance costs throughout the selection process, as the decisions made may affect the overall cost. For example, you may have to decide whether to shut down a lane of traffic to install a low-cost gravity wall system that requires more excavation room or use a more expensive anchored wall system that will minimize excavation requirements and impacts to traffic. In this case, determine whether the cost of traffic impacts and more excavation justifies the cost of the more expensive anchored wall system. Consider long-term maintenance costs when determining wall type.

Decisions regarding aesthetics can also affect the overall cost of the wall system. In general, the least expensive aesthetic options use the structural members of the wall as facing (welded wire or concrete or steel cribbing or bins), whereas the most expensive aesthetic options use textured cast-in-place concrete facias. In general, concrete facings increase in cost in the following order: shotcrete, segmental masonry concrete blocks, precast concrete facing panels, full height precast concrete facing panels, and cast-in-place concrete facing panels. Special architectural treatments

usually increase the cost of any of these facing systems. Special wall terracing to provide locations for plants will also tend to increase costs. Therefore, weigh the costs against the value of the desired aesthetics.

Other factors that affect the costs of wall/slope systems include wall/slope size and length; access at the site and distance to the material supplier location; overall size of the project; and competition between wall suppliers. In general, costs tend to be higher for walls or slopes that are high, but short in length, due to lack of room for equipment to work. Sites that are remote or have difficult local access increase wall/slope costs. Small wall/slope quantities result in high unit costs. Lack of competition between materials or wall system suppliers can result in higher costs as well.

Some of the factors that increase costs are required parts of a project and are therefore unavoidable. Always consider such factors when estimating costs because a requirement may not affect all wall types in the same way. Current cost information can be obtained by consulting the *Bridge Design Manual* or by contacting the HQ Bridge and Structures Office.

(7) Summary

For wall/slope selection, consider factors such as the intended application; the soil/rock conditions in terms of settlement, need for deep foundations, constructibility, and impacts to traffic; and the overall geometry in terms of wall/slope height and length, location of adjacent structures and utilities, aesthetics, and cost. Exhibits 730-1 through 730-6 provide a summary of many of the various wall/slope options available, including their advantages, disadvantages, and limitations. Note that specific wall types in the exhibits may represent multiple wall systems, some or all of which will be proprietary.

730.06 Design Responsibility and Process

(1) General

The retaining walls available for a given project include standard walls, nonstandard walls, and reinforced slopes.

Standard walls are those walls for which standard designs are provided in the Washington State Department of Transportation (WSDOT) *Standard Plans*. These designs are provided for reinforced concrete cantilever walls up to 35 feet in height. The internal stability design and the external stability design for overturning and sliding stability have already been completed for these standard walls. Determine overall slope stability and allowable soil bearing capacity (including settlement considerations) for each standard-design wall location.

Nonstandard walls may be either proprietary (patented or trademarked) or nonproprietary. Proprietary walls are designed by a wall manufacturer for internal and external stability, except bearing capacity, settlement, and overall slope stability, which are determined by WSDOT. Nonstandard nonproprietary walls are fully designed by WSDOT.

The geosynthetic soil reinforcement used in nonstandard nonproprietary geosynthetic walls is considered to be proprietary. It is likely that more than one manufacturer can supply proprietary materials for a nonstandard nonproprietary geosynthetic wall.

Reinforced slopes are similar to nonstandard nonproprietary walls in terms of their design process.

(a) Preapproved Proprietary Walls

Some proprietary wall systems are preapproved. Preapproved proprietary wall systems have been extensively reviewed by the HQ Bridge and Structures Office and the Geotechnical Office. Design procedures and wall details for preapproved walls have already been agreed upon between WSDOT and the proprietary wall manufacturers, allowing the manufacturers to competitively bid a particular project without having a detailed wall design provided in the contract plans.

Note that proprietary wall manufacturers might produce several retaining wall options, and not all options from a given manufacturer have necessarily been preapproved. For example, proprietary wall manufacturers often offer more than one facing alternative. It is possible that some facing alternatives are preapproved, whereas others are not preapproved. WSDOT does not preapprove the manufacturer, but specific wall systems by a given manufacturer can be preapproved.

It is imperative with preapproved systems that the design requirements for all preapproved wall alternatives for a given project be clearly stated so that the wall manufacturer can adapt the preapproved system to specific project conditions. For a given project, coordination of the design of all wall alternatives with all project elements that impact the wall is critical to avoid costly change orders or delays during construction. These elements include drainage features, utilities, luminaires and sign structures, noise walls, traffic barriers, guardrails, or other walls or bridges.

In general, standard walls are the easiest walls to incorporate into project Plans, Specifications, and Estimates (PS&E), but they may not be the most cost-effective option. Preapproved proprietary walls provide more options in terms of cost-effectiveness and aesthetics and are also relatively easy to incorporate into a PS&E. Nonstandard state-designed walls and nonpreapproved proprietary walls generally take more time and effort to incorporate into a PS&E because a complete wall design needs to be developed. Some nonstandard walls (such as state-designed geosynthetic walls) can be designed relatively quickly, require minimal plan preparation effort, and only involve the region and the Geotechnical Office. Other nonstandard walls such as soil nail and anchored wall systems require complex designs, involve both the HQ Bridge and Structures Office and Geotechnical Office, and require a significant number of plan sheets and considerable design effort.

The HQ Bridge and Structures Office maintains a list of the proprietary retaining walls that are preapproved. The region consults the HQ Bridge and Structures Office for the latest list. The region consults the HQ Geotechnical Office for the latest geosynthetic reinforcement list to determine which geosynthetic products are acceptable if a critical geosynthetic wall or reinforced slope application is anticipated.

(b) Experimental Wall Systems

Some proprietary retaining wall systems are classified as experimental by the Federal Highway Administration (FHWA). The HQ Bridge and Structures Office maintains a list of walls that are classified as experimental. If the wall intended

for use is classified as experimental, a work plan is to be prepared by WSDOT and approved by the FHWA.

An approved public interest finding, signed by the Director & State Design Engineer, Development Division, is required for the use of a sole source proprietary wall.

(c) **Gabion Walls**

Gabion walls are nonstandard walls that are to be designed for overturning, sliding, overall slope stability, settlement, and bearing capacity. A full design for gabion walls is not provided in the *Standard Plans*. Gabion baskets are typically 3 feet high by 3 feet wide, and it is typically safe to build gabions two baskets high (6 feet) but only one basket deep. This results in a wall base width of 50% of the wall height, provided soil conditions are reasonably good (medium-dense to dense granular soils are present below and behind the wall).

(2) Responsibility and Process for Design

A flow chart illustrating the process and responsibility for retaining wall/reinforced slope design is provided in [Exhibit 730-13a](#). As shown in the exhibit, the region initiates the process except for walls developed as part of a preliminary bridge plan. These are initiated by the HQ Bridge and Structures Office. In general, it is the responsibility of the design office initiating the design process to coordinate with other groups in the department to identify all wall/slope systems that are appropriate for the project in question. Coordinate with the region and the HQ Bridge and Structures Office, Geotechnical Office, and State Bridge and Structures Architect as early in the process as feasible.

Headquarters or region consultants, if used, are considered an extension of the Headquarters staff and must follow the process summarized in [Exhibit 730-13a](#). All consultant designs, from development of the scope of work to the final product, are to be reviewed and approved by the appropriate Headquarters offices.

(a) **Standard Walls**

The regions are responsible for detailing retaining walls for which standard designs are available.

For standard walls greater than 10 feet in height, and for all standard walls where soft or unstable soil is present beneath or behind the wall, a geotechnical investigation will be conducted, or reviewed and approved, by the HQ Geotechnical Office. Through this investigation, provide the foundation design, including bearing capacity requirements and settlement determination, overall stability, and the selection of the wall types most feasible for the site.

For standard walls 10 feet in height or less where soft or unstable soils are not present, it is the responsibility of the region Materials Laboratory to perform the geotechnical investigation. If it has been verified that soil conditions are adequate for the proposed standard wall that is less than or equal to 10 feet in height, the region establishes the wall footing location based on the embedment criteria in the *Bridge Design Manual*, or places the bottom of the wall footing below any surficial loose soils. During this process, the region also evaluates other wall types that may be feasible for the site in question.

The *Standard Plans* provides design charts and details for standard reinforced concrete cantilever walls. The *Standard Plans* are used to size the walls and determine the factored bearing pressure to compare with the factored bearing resistance determined from the geotechnical investigation. The charts provide maximum soil pressure for the LRFD service, strength, and extreme event limit states. Factored bearing resistance for the LRFD service, strength, and extreme event limit states can be obtained from the HQ Geotechnical Office for standard walls over 10 feet in height and from the region Materials Laboratory for standard walls less than or equal to 10 feet in height. The *Standard Plans* can be used for the wall design if the factored bearing resistance exceeds the maximum soil pressure shown in the *Standard Plans* for the respective LRFD limit states.

Contact the HQ Bridge and Structures Office if the factored bearing resistance provided by the geotechnical investigation does not exceed the maximum soil pressure shown in the *Standard Plans* for one or all of the LRFD limit states. The wall is considered a nonstandard wall design and the *Standard Plans* cannot be used.

If the standard wall must support surcharge loads from bridge or building foundations, other retaining walls, noise walls, or other types of surcharge loads, a special wall design is required. The wall is considered to be supporting the surcharge load and is treated as a nonstandard wall if the surcharge load is located within a 1H:1V slope projected up from the bottom of the back of the wall. Contact the HQ Bridge and Structures Office for assistance

The *Standard Plans* provides eight types of reinforced concrete cantilever walls (which represent eight loading cases). Reinforced concrete retaining walls Types 5 through 8 are not designed to withstand western Washington earthquake forces and are not to be used in western Washington (west of the Cascade crest).

Once the geotechnical and architectural assessments have been completed, the region completes the PS&E for the standard wall option(s) selected, including a generalized wall profile and plan, a typical cross section as appropriate, and details for desired wall appurtenances, drainage details, and other details as needed.

Metal bin walls, Types 1 and 2, have been deleted from the *Standard Plans* and are therefore no longer standard walls. Metal bin walls are seldom used due to cost and undesirable aesthetics. If this type of wall is proposed, contact the HQ Bridge and Structures Office for plan details and toe bearing pressures. The applied toe bearing pressure will then have to be evaluated by the HQ Geotechnical Office to determine whether the site soil conditions are appropriate for the applied load and anticipated settlement.

(b) Preapproved Proprietary Walls

Final approval of preapproved proprietary wall design, with the exception of geosynthetic walls, is the responsibility of the HQ Bridge and Structures Office. Final approval of the design of preapproved proprietary geosynthetic walls is the responsibility of the HQ Geotechnical Office. It is the region's responsibility to coordinate the design effort for all preapproved wall systems.

The region Materials Laboratory performs the geotechnical investigation for preapproved proprietary walls 10 feet in height or less that are not bearing on soft or unstable soils. In all other cases, it is the responsibility of the HQ Geotechnical Office to conduct, or review and approve, the geotechnical investigation for the wall. The region also coordinates with the State Bridge and Structures Architect to ensure that the wall options selected meet the aesthetic requirements for the site.

Once the geotechnical and architectural assessments have been completed and the desired wall alternatives selected, it is the responsibility of the region to contact the suppliers of the selected preapproved systems to confirm in writing the adequacy and availability of the systems for the proposed use.

Include a minimum of three different wall systems in the PS&E for any project with federal participation that includes a proprietary wall system unless specific justification is provided. Standard walls can be alternatives.

Once confirmation of adequacy and availability has been received, the region contacts the HQ Bridge and Structures Office for special provisions for the selected wall systems and proceeds to finalize the contract PS&E in accordance with the *Plans Preparation Manual*. Provide the allowable bearing capacity and foundation embedment criteria for the wall, as well as backfill and foundation soil properties, in the Special Provisions. In general, assume that gravel borrow or better-quality backfill material will be used for the walls when assessing soil parameters.

Complete wall plans and designs for the proprietary wall options will not be developed until after the contract is awarded, but will be developed by the proprietary wall supplier as shop drawings after the contract is awarded. Therefore, include a general wall plan; a profile showing neat line top and bottom of the wall; a final ground line in front of and in back of the wall; a typical cross-section; and the generic details for the desired appurtenances and drainage requirements in the contract PS&E for the proprietary walls. Estimate the ground line in back of the wall based on a nominal 1.5-foot facing thickness (and state this on the wall plan sheets). Include load or other design acceptance requirements for these appurtenances in the PS&E. Contact the HQ Bridge and Structures Office for assistance.

It is best to locate catch basins, grate inlets, signal foundations, and the like outside the reinforced backfill zone of MSE walls to avoid interference with the soil reinforcement. In those cases where conflict with these reinforcement obstructions cannot be avoided, indicate the location(s) and dimensions of the reinforcement obstruction(s) relative to the wall on the plans. Contact the HQ Bridge and Structures Office for preapproved wall details and designs for size and location of obstructions and to obtain the generic details that are to be provided in the plans. If the obstruction is too large or too close to the wall face, a special design may be required to accommodate the obstruction, and the wall is treated as a nonpreapproved proprietary wall.

A special design is required if the wall will support structure foundations, other retaining walls, noise walls, signs or sign bridges, luminaires, or other types of surcharge loads. The wall is considered to be supporting the surcharge load if the surcharge is located within a 1H:1V slope projected from the bottom of the

back of the wall. For MSE walls, the back of the wall is considered to be the back of the soil reinforcement layers. If this situation occurs, the wall is treated as a nonpreapproved proprietary wall.

For those alternative wall systems that have the same face embedment criteria, the wall face quantities depicted in the plans for each alternative are to be identical. To provide an equal basis for competition, the region determines wall face quantities based on neat lines.

Once the detailed wall plans and designs are available as shop drawings after contract award, the HQ Bridge and Structures Office will review and approve the wall shop drawings and calculations, with the exception of geosynthetic walls. They are reviewed and approved by the HQ Geotechnical Office.

(c) Nonpreapproved Proprietary Walls

Final approval authority for nonpreapproved proprietary wall design is the same as for preapproved proprietary walls. The region initiates the design effort for all nonpreapproved wall systems by submitting wall plan, profile, cross section, and other information for the proposed wall to the HQ Bridge and Structures Office, with copies to the HQ Geotechnical Office and the State Bridge and Structures Architect. The HQ Bridge and Structures Office coordinates the wall design effort.

Once the geotechnical and architectural assessments have been completed and the desired wall types selected, the HQ Bridge and Structures Office contacts suppliers of the selected nonpreapproved wall systems to obtain and review detailed wall designs and plans to be included in the contract PS&E.

To ensure fair competition between all wall alternatives included in the PS&E, make the wall face quantities identical for those wall systems subject to the same face embedment requirements.

The HQ Bridge and Structures Office develops the special provisions and cost estimates for the nonpreapproved proprietary walls and sends the wall PS&E to the region for inclusion in the final PS&E in accordance with the *Plans Preparation Manual*.

(d) Nonstandard Nonproprietary Walls

With the exception of rockeries over 5 feet high, nonproprietary geosynthetic walls and reinforced slopes, and soil nail walls, the HQ Bridge and Structures Office coordinates with the HQ Geotechnical Office and the State Bridge and Structures Architect to carry out the design of all nonstandard, nonproprietary walls. The HQ Bridge and Structures Office develops the wall preliminary plan from site data provided by the region, completes the wall design, and develops the nonstandard nonproprietary wall PS&E package for inclusion in the contract.

For rockeries over 5 feet high, nonproprietary geosynthetic walls and reinforced slopes, and soil nail walls, the region develops wall/slope profiles, plans, and cross sections and submits them to the HQ Geotechnical Office to complete a detailed wall/slope design.

For geosynthetic walls and slopes and for rockeries, the region provides overall coordination of the wall/slope design effort, including coordination with the State Bridge and Structures Architect regarding aesthetics and finishes, and the region or HQ Landscape Architect if the wall uses vegetation on the face.

The HQ Geotechnical Office has overall approval authority for the wall design. Once the wall design has been completed, the HQ Geotechnical Office, and in some cases the HQ Bridge and Structures Office, provides geotechnical and structural plan details to be included in the region plan sheets and special provisions for the PS&E. The region then completes the PS&E package.

For soil nail walls, once the HQ Geotechnical Office has performed the geotechnical design, the HQ Bridge and Structures Office, in cooperation with the HQ Geotechnical Office, coordinates the design effort and completes the PS&E package.

(3) Guidelines for Wall/Slope Data Submission for Design

(a) Standard Walls, Proprietary Walls, Geosynthetic Walls/Slopes, and Soil Nail Walls

Where Headquarters involvement in retaining wall/slope design is required (as it is for standard walls and preapproved proprietary walls over 10 feet in height, gabions over 6 feet in height, rockeries over 5 feet in height, all nonpreapproved proprietary walls, geosynthetic walls/slopes, and all soil nail walls), the region submits the following information to the HQ Geotechnical Office or HQ Bridge and Structures Office as appropriate:

- Wall/slope plans.
- Profiles showing the existing and final grades in front of and behind the wall.
- Wall/slope cross sections (typically every 50 feet) or InRoads files that define the existing and new ground line above and below the wall/slope and show stations and offsets.
- Location of right of way lines and other constraints to wall/slope construction.
- Location of adjacent existing and/or proposed structures, utilities, and obstructions.
- Desired aesthetics.
- Date design must be completed.
- Key region contacts for the project.

Note that for the purpose of defining the final wall geometry, it is best to base existing ground measurements on physical survey data rather than solely on photogrammetry. In addition, the region is to complete a Retaining Wall/Reinforced Slope Site Data Check List, DOT Form 351-009 EF, for each wall or group of walls submitted.

(b) Nonstandard Walls, Except Geosynthetic Walls/Slopes and Soil Nail Walls

In this case, the region is to submit site data in accordance with [Chapter 710](#). Additionally, the region is to complete a Retaining Wall/Reinforced Slope Site Data Check List, DOT Form 351-009 EF, for each wall or group of walls.

730.07 Documentation

Refer to [Chapter 300](#) for design documentation requirements.

Specific Wall Type	Advantages	Disadvantages	Limitations
Steel soil reinforcement with full height precast concrete panels	Relatively low cost.	Can tolerate little settlement; generally requires high-quality backfill; wide base width required (70% of wall height).	Applicable primarily to fill situations; maximum feasible height is approximately 20 feet.
Steel soil reinforcement with modular precast concrete panels	Relatively low cost; flexible enough to handle significant settlement.	Generally requires high-quality backfill; wide base width required (70% of wall height).	Applicable primarily to fill situations; maximum height of 33 feet; heights over 33 feet require a special design.
Steel soil reinforcement with welded wire and cast-in-place concrete face	Can tolerate large short-term settlements.	Relatively high cost; cannot tolerate long-term settlement; generally requires high-quality wall backfill soil; wide base width required (70% of wall height); typically requires a settlement delay during construction.	Applicable primarily to fill situations; maximum height of 33 feet for routine designs; heights over 33 feet require a special design.
Steel soil reinforcement with welded wire face only	Can tolerate large short-term settlements; low cost.	Aesthetics, unless face plantings can be established; generally requires high-quality backfill; wide base width required (70% of wall height).	Applicable primarily to fill situations; maximum height of 33 feet for routine designs; heights over 33 feet require a special design.
Segmental masonry concrete block-faced walls, generally with geosynthetic soil reinforcement	Low cost; flexible enough to handle significant settlement.	Internal wall deformations may be greater for steel reinforced systems, but are acceptable for most applications; generally requires high-quality backfill; wide base required (70% of wall height).	Applicable primarily to fill situations; in general, limited to a wall height of 20 feet or less; greater wall heights may be feasible by special design in areas of low seismic activity and when geosynthetic products are used in which long-term product durability is well defined. (See <i>Qualified Products List</i> .)
Geosynthetic walls with a shotcrete or cast-in-place concrete face	Very low cost, especially with shotcrete face; can tolerate large short-term settlements.	Internal wall deformations may be greater than for steel reinforced systems, but are still acceptable for most applications; generally requires high-quality backfill; wide base width required (70% of wall height).	Applicable primarily to fill situations; in general, limited to wall height of 20 feet or less unless using geosynthetic products in which long-term product durability is well defined. (See <i>Qualified Products List</i> .) For qualified products, heights of 33 feet or more are possible.

**Summary of Mechanically Stabilized Earth (MSE) Gravity
Wall/Slope Options Available**
Exhibit 730-1

Specific Wall Type	Advantages	Disadvantages	Limitations
Geosynthetic walls with a welded wire face	Very low cost; can tolerate large long-term settlements.	Internal wall deformations may be greater than for steel reinforced systems, but are still acceptable for most applications; generally requires high-quality wall backfill soil; wide base width required (70% of wall height).	Applicable primarily to fill situations; in general, limited to wall height of 20 feet or less unless using geosynthetic products in which long-term product durability is well defined. (See <i>Qualified Products List</i> .) For qualified products, heights of 33 feet or more are possible.
Geosynthetic walls with a geosynthetic face	Lowest cost of all wall options; can tolerate large long-term settlements.	Internal wall deformations may be greater than for steel reinforced systems, but are still acceptable for most applications; generally requires high-quality backfill; wide base width required (70% of wall height); durability of wall facing.	Applicable primarily to fill situations; use only for temporary applications due to durability of facing; can be designed for wall heights of 40 feet or more.
Soil nail walls	Relatively low cost; can be used in areas with restricted overhead or lateral clearance.	Allow adequate standup time for soil/rock to stand in a vertical cut approximately 6 feet high for at least 1 to 2 days; not feasible for bouldery soils; may require an easement for the nails.	Applicable to cut situations only; not recommended in clean or water-bearing sands and gravels, in bouldery soils that can interfere with nail installation, or in landslide deposits, especially where deep potential failure surfaces are present; maximum wall heights of 35 feet are feasible, though greater wall heights are possible in excellent soil/rock conditions. A special design is always required.

**Summary of Mechanically Stabilized Earth (MSE) Gravity
Wall/Slope Options Available**

Exhibit 730-1 (continued)

Specific Wall Type	Advantages	Disadvantages	Limitations
Concrete crib walls	Relatively low cost; quantity of high-quality backfill required relatively small; relatively narrow base width, on the order of 50 to 60% of the wall height; can tolerate moderate settlements.	Aesthetics.	Applicable to cut and fill situations; reinforced concrete typically can be designed for heights of up to 33 feet and unreinforced concrete up to 16 feet; not used to support bridge or building foundations.
Metal crib walls	Quantity of high-quality backfill required relatively small; relatively narrow base width, on the order of 50 to 60% of the wall height; can tolerate moderate settlements.	Relatively high cost; aesthetics.	Applicable to cut and fill situations; can be designed routinely for heights up to 35 feet; not used to support bridge or building foundations.
Timber crib walls	Low cost; minimal high-quality backfill required; relatively narrow base width, on the order of 50 to 60% of the wall height; can tolerate moderate settlements.	Design life relatively short; aesthetics.	Applicable to cut and fill situations; can be designed for heights up to 16 feet; not used to support structure foundations.
Concrete bin walls	Relatively low cost; narrow base width, on the order of 50 to 60% of the wall height; can tolerate moderate settlements.	Aesthetics.	Applicable to cut and fill situations; can be designed routinely for heights up to 25 feet; not used to support bridge or building foundations.
Gabion walls	Relatively narrow base width, on the order of 50 to 60% of the wall height; can tolerate moderate settlements.	Relatively high cost, depending on proximity to source of high-quality angular rock to fill baskets.	Applicable to cut and fill situations; can be designed routinely for heights up to 15 feet, and by special design up to 21 feet; not used to support structure foundations.

Summary of Prefabricated Modular Gravity Wall Options Available
Exhibit 730-2

Specific Wall Type	Advantages	Disadvantages	Limitations
Mortar rubble masonry walls	Quantity of high-quality backfill required is relatively small.	High cost; relatively wide base width, on the order of 60 to 70% of the wall height; cannot tolerate settlement.	Applicable mainly to fill situations where foundation conditions consist of very dense soil or rock; due to expense, only used in areas where other mortar rubble masonry walls are present and it is desired to match aesthetics; typically can be designed for maximum heights of 25 feet.
Unreinforced concrete gravity walls	Quantity of high-quality backfill required is relatively small.	High cost; relatively wide base width, on the order of 60 to 70% of the wall height; cannot tolerate settlement.	Applicable mainly to fill situations where foundation conditions consist of very dense soil or rock; due to expense, only used in areas where other gravity walls are present and it is desired to match aesthetics; typically can be designed for maximum heights of 25 feet.
Reinforced concrete cantilever walls	Relatively narrow base width on the order of 50 to 60% of the wall height; can be used to support structure foundations by special design.	High cost; cannot tolerate much settlement; relatively deep embedment might be required on sloping ground due to toe in front of face wall.	Applicable to cut and fill situations; can be routinely designed for heights up to 35 feet.
Reinforced concrete counterfort walls	Relatively narrow base width on the order of 50 to 60% of the wall height; can be used to support structure foundations by special design.	High cost; cannot tolerate much settlement; relatively deep embedment might be required on sloping ground due to toe in front of wall face.	Applicable to cut and fill situations; can be routinely designed for heights up to 50 feet; proprietary versions are typically 33 feet maximum.

Summary of Rigid Gravity and Semigravity Wall Options Available
Exhibit 730-3

Specific Wall Type	Advantages	Disadvantages	Limitations
Soldier pile wall	Very narrow base width; deep embedment to get below potential failure surfaces; relatively easy to obtain.	Relatively high cost.	Applicable mainly to cut situations; maximum feasible exposed height is on the order of 10 feet; difficult to install in bouldery soil or soil with water-bearing sands.
Sheet pile wall	Low to moderate cost; very narrow base width.	Difficult to get embedment in dense or bouldery soils; difficult to protect against corrosion.	Applicable mainly to cut situations in soil; maximum feasible exposed height is on the order of 10 feet.
Cylinder pile wall	Relatively narrow base width; can produce stable wall even if deep potential failure surfaces present.	Very high cost.	Applicable mainly to cut situations; maximum feasible exposed height is on the order of 20 to 25 feet depending on the passive resistance available; can be installed in bouldery conditions, though cost will increase.
Slurry wall	Relatively narrow base width; can produce stable wall even if deep potential failure surfaces present.	Very high cost; difficult construction.	Applicable mainly to cut situations; maximum feasible exposed height is on the order of 20 to 25 feet, depending on passive resistance available.

Summary of Nongravity Wall Options Available

Exhibit 730-4

Specific Wall Type	Advantages	Disadvantages	Limitations
All nongravity cantilever walls with tiebacks	Relatively narrow base width; can produce stable wall even if deep potential failure surfaces present.	Very high cost; difficult to install in areas where vertical or lateral clearance is limited; easements may be necessary; installation activities may impact adjacent traffic.	Applicable only to cut situations; can be designed for heights of 50 feet or more depending on the specifics of the structure of the wall.
All nongravity cantilever walls with deadman anchors	Relatively narrow base width; can produce stable wall even if deep potential failure surfaces present.	Moderate to high cost; access required behind wall to dig trench for deadman anchor; may impact traffic during deadman installation; easements may be necessary.	Applicable to partial cut/fill situations; can be designed for wall heights of approximately 16 feet.

Summary of Anchored Wall Options Available

Exhibit 730-5

Wall/Slope Classification	Specific Wall Type	Advantages	Disadvantages	Limitations
Rockerries	Only variations are in rock sizes used and overall wall dimensions.	Low cost; narrow base width on the order of 30% of the wall height required.	Slope needs to be at least marginally stable without rockery present; cannot tolerate much settlement.	Applicable to both cut and fill situations; maximum feasible height in a cut, even for excellent soil conditions, is approx. 16 feet and 8 feet in fill situations.
Reinforced slopes	Only variations are in geosynthetic products used and in erosion-control techniques used on slope face.	Low cost; can tolerate large settlements; can adapt well to sloping ground conditions to minimize excavation required; high-quality fill is not a requirement.	Room required between the right of way line and the edge of the shoulder to install a 1H:1V slope.	Best suited to sloping fill situations; maximum height limited to 30 feet unless geosynthetic products are used in which long-term product durability is well defined. Certain products can be used in critical applications and for greater slope heights on the order of 60 feet or more, but consider need, landscaping maintenance, and the reach of available maintenance equipment.

Other Wall/Slope Options Available

Exhibit 730-6

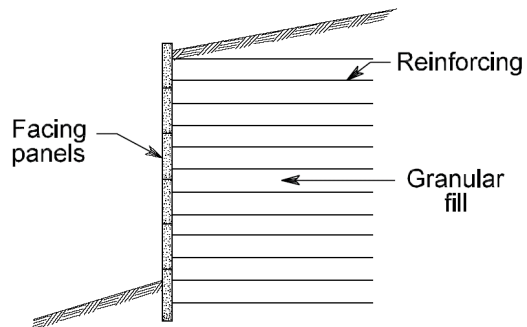

MSE Wall with Modular Precast Concrete Facing Panels

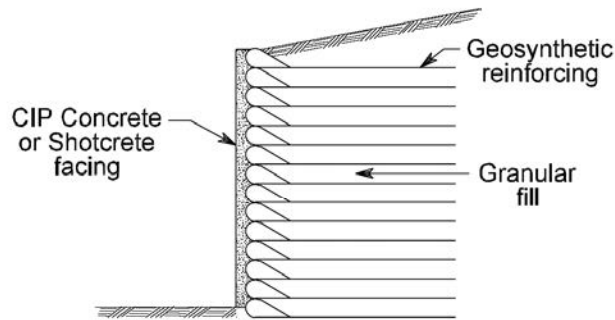

MSE Wall with Geosynthetic Reinforcement and CIP Concrete or Shotcrete Facing

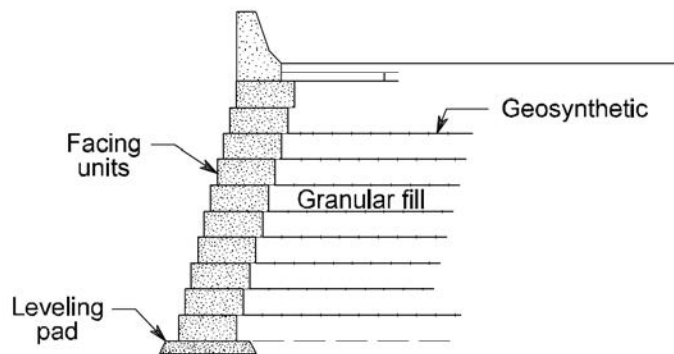

MSE Wall with Segmental Concrete Block Facing

Typical Mechanically Stabilized Earth Gravity Walls
Exhibit 730-7

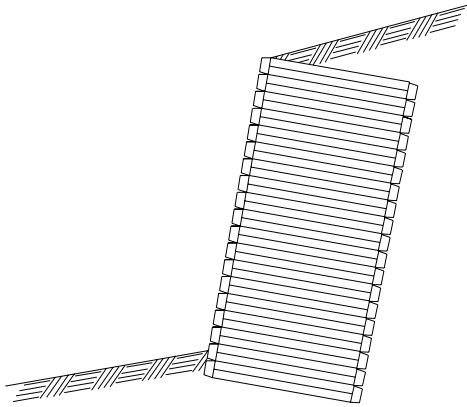

Metal Bin Wall

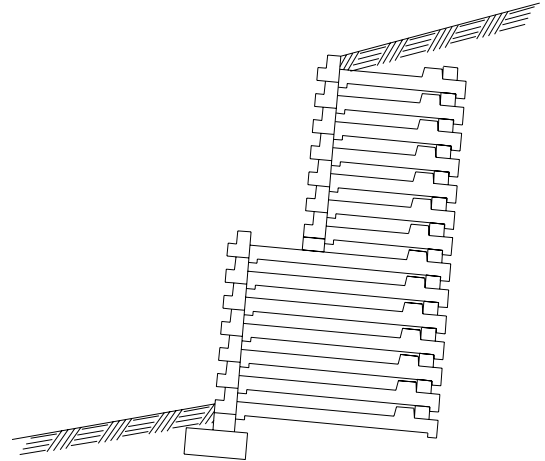

Precast Concrete Crib Wall

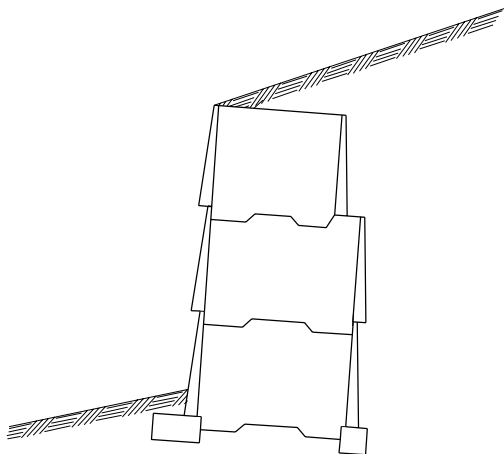

Precast Concrete Bin Wall

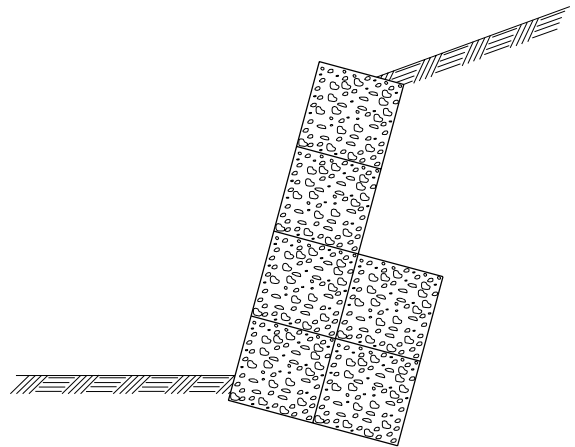

Gabion Wall

Typical Prefabricated Modular Gravity Walls
Exhibit 730-8

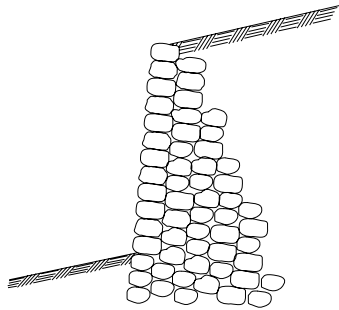

Mortar Rubble Masonry Rigid Gravity Wall

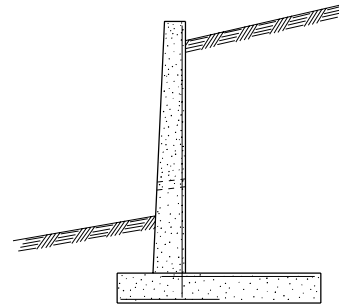

Reinforced Concrete Cantilever Semigravity Wall

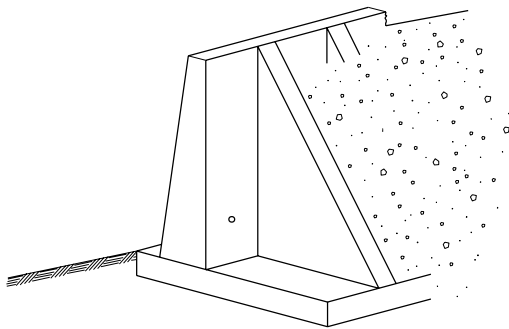

Reinforced Concrete Counterfort Semigravity Wall

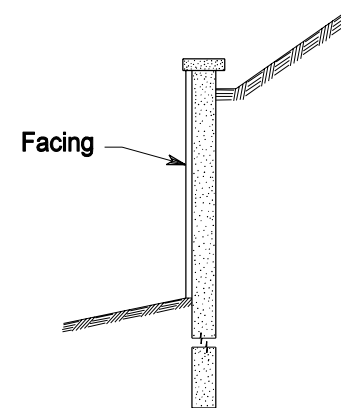

Slurry or Cylinder Pile Nongravity Cantilever Wall

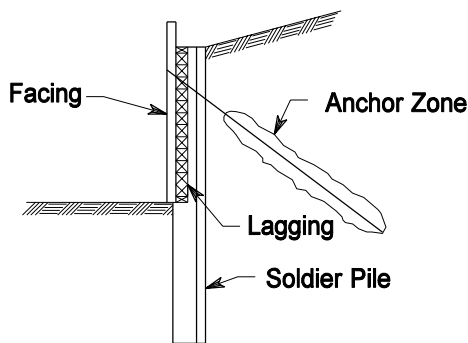

Soldier Pile Tieback Wall

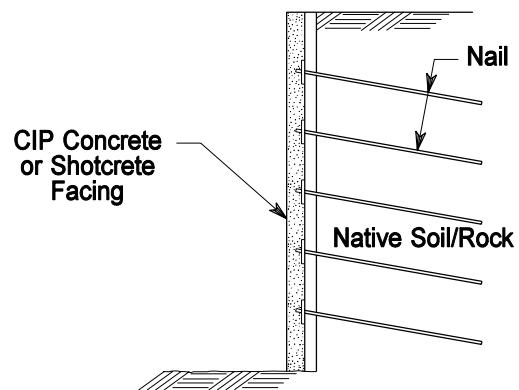

Soil Nail Wall in Cut

Typical Rigid Gravity, Semigravity Cantilever, Nongravity Cantilever, and Anchored Walls
Exhibit 730-9

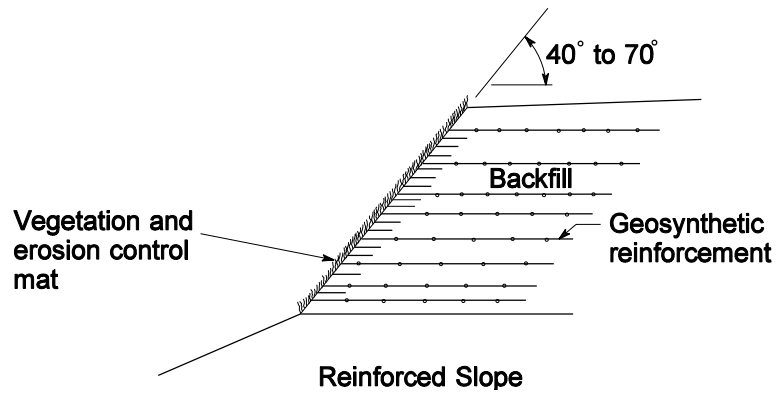
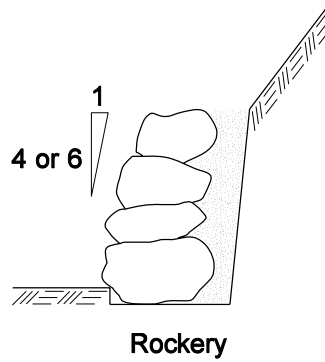

Typical Rockery and Reinforced Slopes
Exhibit 730-10

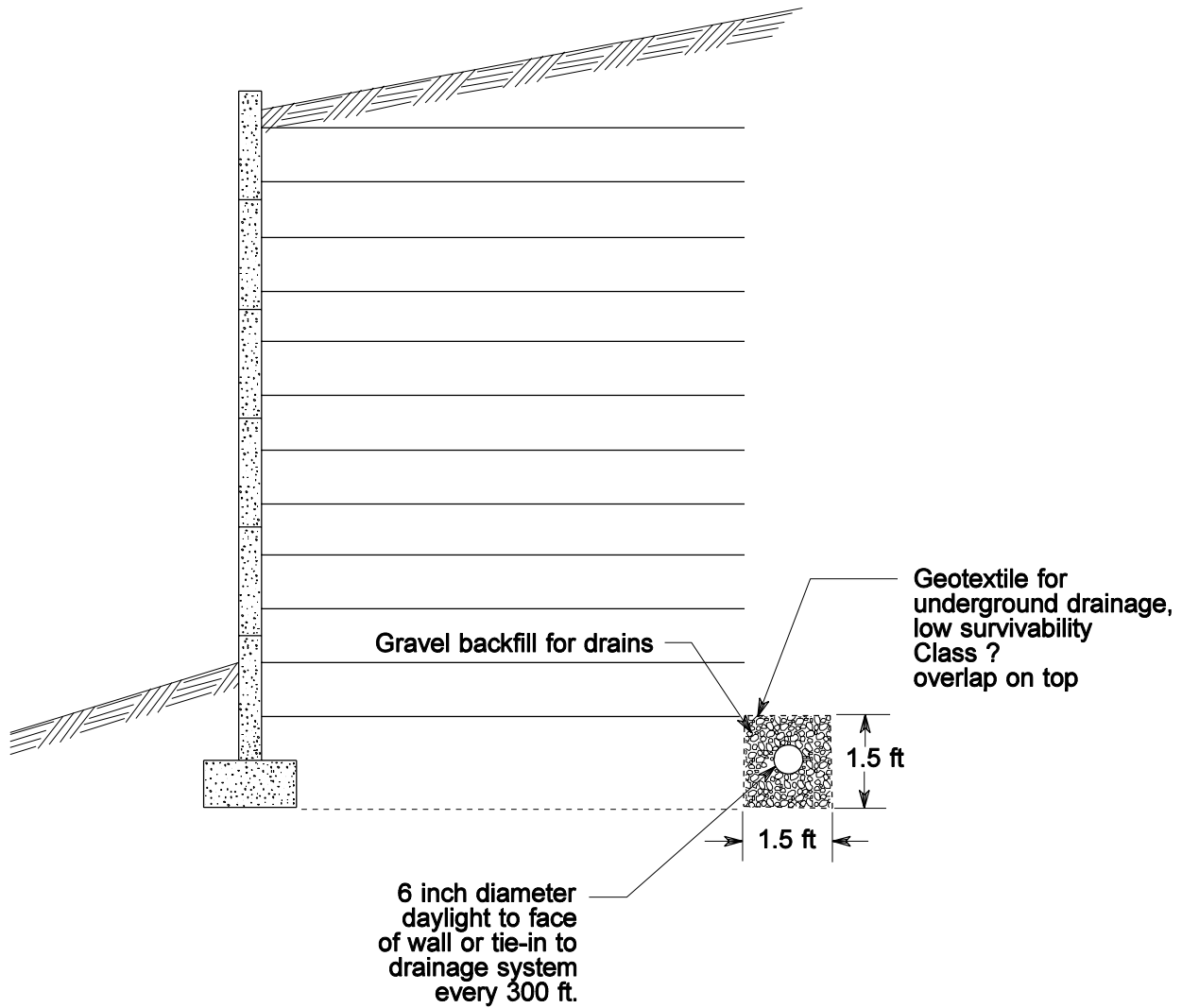

MSE Wall Drainage Detail
Exhibit 730-11

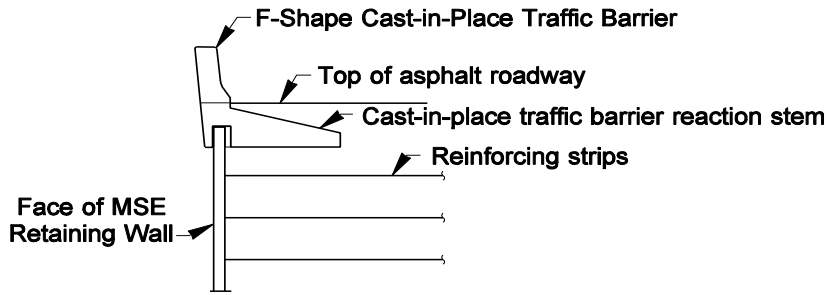

Concrete Traffic Barrier with Asphalt Roadway

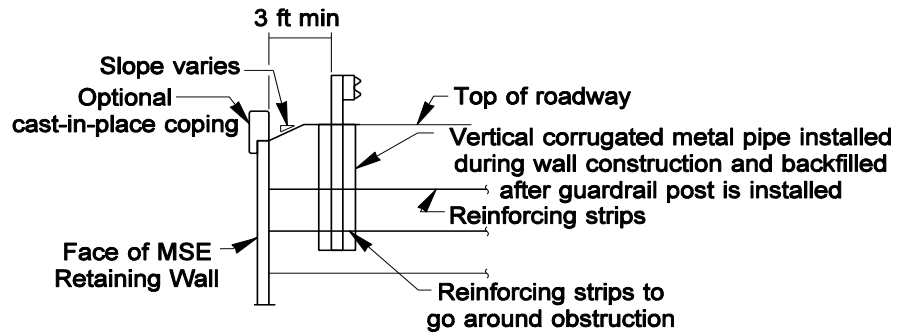

Beam Guardrail on Top of MSE Retaining Wall

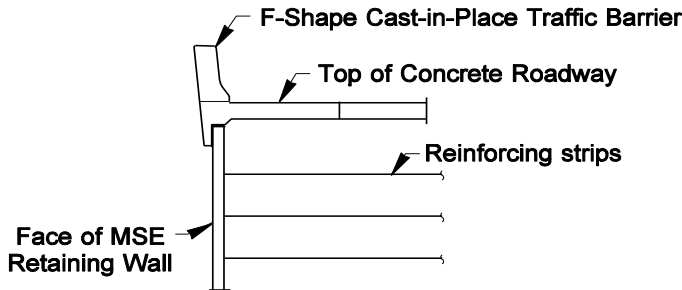

Concrete Traffic Barrier with Concrete Roadway

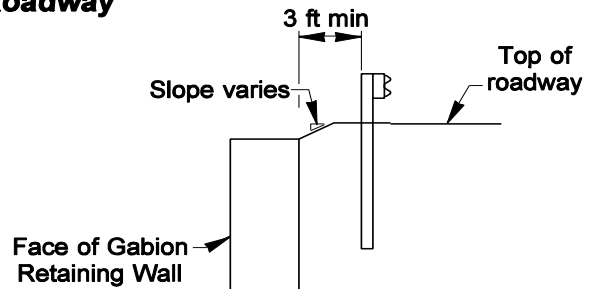

Beam Guardrail on Top of Gabion Wall

Retaining Walls With Traffic Barriers

Exhibit 730-12

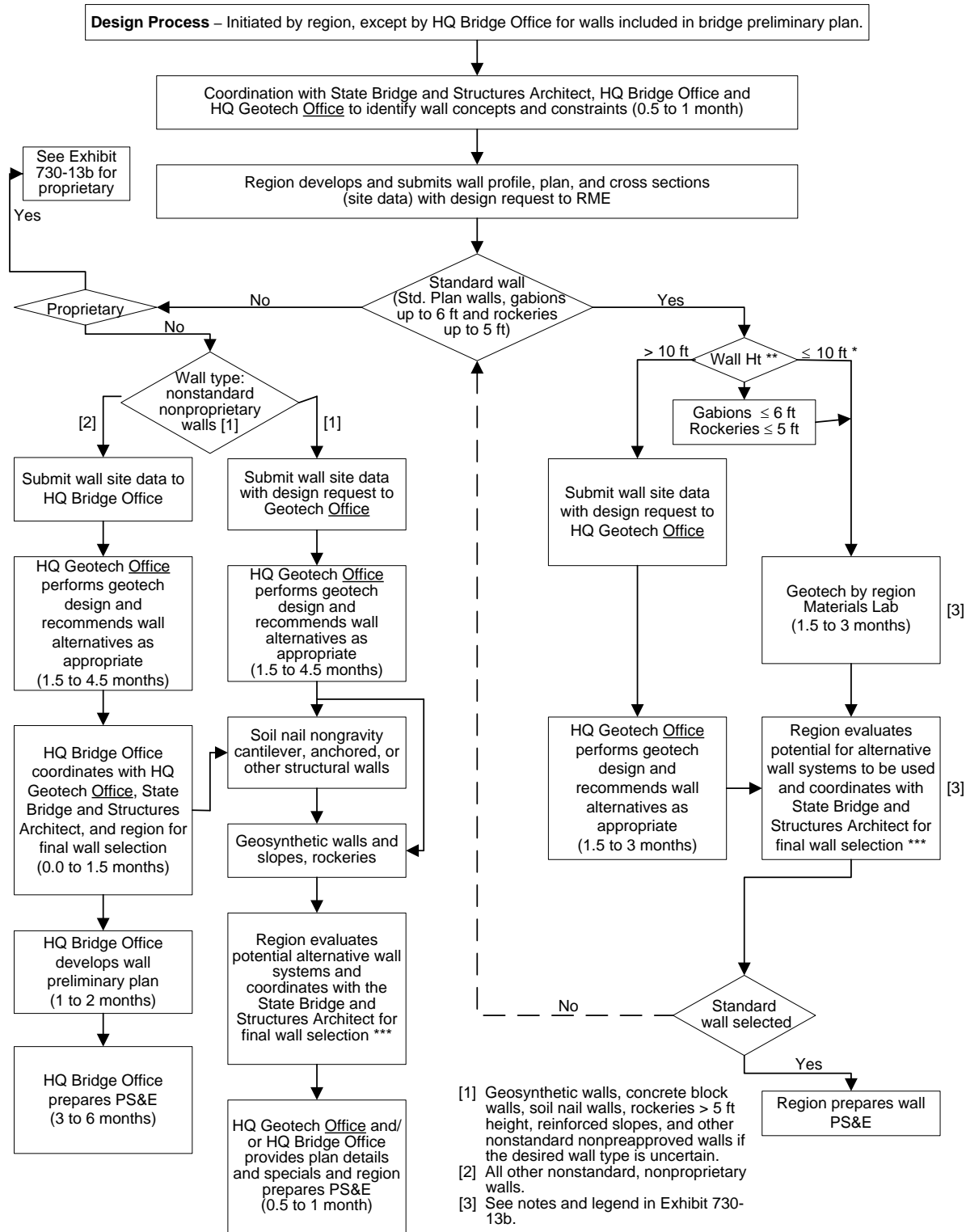

Retaining Wall Design Process
Exhibit 730-13a

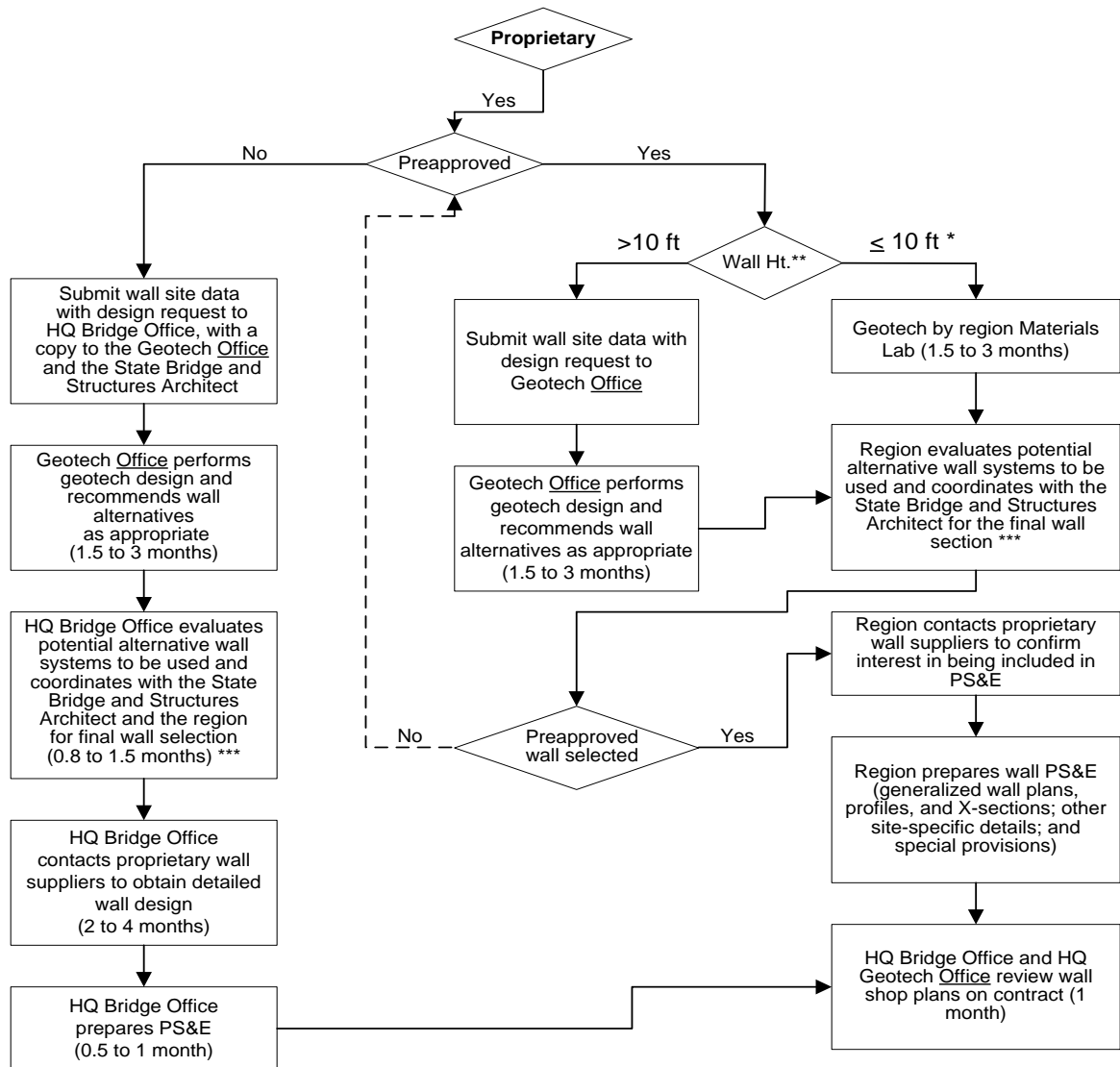

Notes:

“HQ Bridge Office” refers to the WSDOT HQ Bridge and Structures Office.

“Geotech Office” refers to the WSDOT HQ Geotechnical Office.

“State Bridge and Structures Architect” refers to the Architecture Section, HQ Bridge and Structures Office.

Regarding time estimates:

- Assumes no major changes in the wall scope during design.
- Actual times may vary depending on complexity of project.
- Contact appropriate design offices for more accurate estimates of time.

Legend:

Region provides courtesy copy of geotechnical report to HQ Geotechnical Office.

*Assumes soft or unstable soil not present and wall does not support other structures.

**The preapproved maximum wall height is generally 33 feet. Some proprietary walls might be less. (Check with the HQ Bridge and Structures Office.)

***If the final wall selected is a different type than assumed, go back through the design process to ensure that all the steps have been taken.

Retaining Wall Design Process: Proprietary

Exhibit 730-13b

